

SIMPLY CLEVER

ŠKODA



ŠKODA Roomster Owner's Manual





5J7012720AH

Preface

You have opted for a ŠKODA - our sincere thanks for your confidence in us.

The description of the vehicle operation, important information about safety, vehicle care, maintenance and self-help, as well as technical vehicle data, are given in this manual.

Please read this Owner's Manual carefully, because the operation in accordance with these instructions is a prerequisite for proper use of the vehicle.

We hope you enjoy driving your ŠKODA, and wish you a pleasant journey at all times.

Your ŠKODA AUTO a.s. (hereinafter referred to only as ŠKODA or manufacturer)



5J701Z720AH

Table of Contents

Board literature	4
Notes	5
Structure and more information about the Operating Instructions	6
Abbreviations	
Safety	
Passive Safety	8
General information	8
Correct and safe seated position	9
Seat belts	12
Using seat belts	12
Inertia reels and belt tensioners	15
Airbag system	16
Description of the airbag system	16
Airbag overview	17
Deactivating airbags	20
Transporting children safely	22
Child seat	22
Fastening systems	25
Operation	
Cockpit	29
Overview	28
Instruments and Indicator Lights	30
Instrument cluster	30
Multifunction display (MFD)	33
Service Interval Display	36
MAXI DOT display	37
Warning lights	39

Unlocking and locking	47
Unlocking and locking	47
Central locking system	49
Remote control	52
Anti-theft alarm system	53
Luggage compartment lid	54
Electrical power windows	55
Mechanical windows	58

Lights and visibility	59
Lights	59
Interior lights	63
Visibility	64
Windscreen wipers and washers	65
Rear window	67

Seats and stowing	69
Front seats	69
Rear seats	70
Head restraints	72
Boot	73
Variable loading floor in the luggage compartment (Estate)	76
Bicycle carrier in the luggage compartment	78
Roof rack system	80
Useful equipment	80
Storage compartments	83
Praktik	87

Heating and air-conditioning	90
Heating, ventilation, cooling	90
Heating	91

Air conditioning system (manual air conditioning system)	93
Climatronic (automatic air conditioning system)	95
Communication and multimedia	97
Universal telephone preinstallation GSM II	97
Voice control	102
Multimedia	103

Driving

Starting-off and Driving	106
Starting and stopping the engine	106
Brakes	108
Manual gear changing and pedals	109
Automatic transmission	110
Running in	113
Economical driving and environmental sustainability	113
Avoiding damage to your vehicle	117
Driving abroad	118

Assist systems	119
Brake assist systems	119
Parking aid	120
Cruise Control System	121
START-STOP	123
Tyre pressure monitoring	125

Hitch and trailer	126
Hitch	126
Trailer	129

General Maintenance

Car care	132
Services, modifications and technical alterations	132
Washing vehicle	135

Taking care of your vehicle exterior	136
Taking care of the interior	139
Inspecting and replenishing	142
Fuel	142
Engine compartment	145
Engine oil	148
Coolant	150
Brake fluid	152
Vehicle battery	153
Wheels	156
Tyres and wheel rims	156
Approved tyre / rim combinations	160
Winter operation	163
Do-it-yourself	
Emergency equipment and self-help	165
Emergency equipment	165
Changing a wheel	166
Puncture set	169
Jump-starting	172
Towing the vehicle	173
Fuses and light bulbs	175
Fuses	175
Replacing bulbs	178
Technical data	
Technical data	183
Vehicle data	183
Index	

Board literature

You always find these **Operating Instructions** and the **Service Plan** in the on-board literature for your vehicle.

Depending on the equipment, the on-board literature can also contain **The radio instruction manual** or **Manual of the navigation system** and in some countries also the brochure **On the road**.

Owner's Manual

These operating instructions apply to all **body variants** of the vehicle and all related **model versions** as well as all **equipment levels**.

This owner's manual describes all **possible equipment variants** without identifying them as special equipment, model variants or market-dependent equipment. Consequently, this vehicle **does not contain all of the equipment components** described in this Owner's Manual.

The scope of equipment on your vehicle depends on your purchase contract for the vehicle. For questions regarding the scope of equipment, please contact a ŠKODA Partner, if required.

The **Pictures** in this manual are for illustrative purposes only. The illustrations can differ in minor details from your vehicle; they are only intended to provide general information.

ŠKODA AUTO a.s. pursues a policy of constant product and model development. Changes in terms of supply scope are possible at any time with regard to design, equipment and technology. The information listed in this operating manual corresponds to the information available at the time of going to press.

It is therefore not possible for legal claims to be made based on the technical data, illustrations and information contained in this Owner's Manual.

Service schedule

The service plan includes the documentation of the vehicle handover information with regard to warranty and service events.

The radio instruction manual

The instruction manual of the radio contains a description of the operation of the radio, and possibly also some functions and vehicle systems.

Manual of the navigation system

The manual of the navigation system includes a description of the operation of the navigation system, and possibly also some functions and vehicle systems.

Move Brochure

The Move brochure contains phone numbers of importers and service offices in individual countries, together with emergency numbers.

Notes

Terms used

The on-board literature contains the following terms relating to the service work for your vehicle.

"Specialist garage" - a workshop that carries out specialist service tasks for ŠKODA vehicles. A specialist garage can be a ŠKODA partner, a ŠKODA service partner or an independent workshop.

"ŠKODA service partner" - A Workshop that has been contractually authorised by the manufacturer ŠKODA AUTO a.s. or its sales partner to perform service tasks on ŠKODA vehicles and to sell ŠKODA Genuine Parts.

"ŠKODA partner" - A company that has been authorised by the manufacturer ŠKODA AUTO a.s. or its sales partner to sell new ŠKODA vehicles and, when applicable, to service them using ŠKODA Genuine Parts and sell ŠKODA Genuine Parts.

Explanation of symbols

An overview of the symbols used in the instruction manual and a brief explanation of their meaning.



Reference to the introductory module of a chapter with important information and safety warnings.



Continuation of the module on the next page.



Situations where the vehicle must be stopped as soon as possible.



Trademark.



Telephone operation in the MAXI DOT display .



Text display in the segment display.

WARNING

Texts with this symbol draw attention to threats of a **serious accident, injury or loss of life**.

CAUTION

Texts with this symbol draw attention to the risk of vehicle damage or possible inoperability of some systems.



For the sake of the environment

Texts with this symbol contain information on environmental protection as well as tips for economical operation.

Note

Texts with this symbol contain additional information.

Structure and more information about the Operating Instructions

Structure of the manual

The operating manual is hierarchically divided into the following areas.

- **Section** (e.g. Safety) - the title of the Section is always indicated at the lower left side
 - **Main chapters** (e.g. Airbag System) - the title of the main chapter is always indicated at the lower right side
 - **Chapter** (e.g. Airbag Overview)
 -  **Introduction to the topic** - Module Overview within the chapter introductory information about the chapter content, if necessary, valid for the entire chapter notes
 - **Module** (e.g. Front Airbags)

Information Search

When searching for information in the operating instructions, we recommend using the **Index** at the end of the manual.

Direction indications

All direction indications such as "left", "right", "front", "rear" relate to the forward direction of travel of the vehicle.

Units of measurement

The volume, weight, speed and length data are given in metric units, unless otherwise indicated.

Display

In this owner's manual, the screen on the MAXI DOT display is used as the display illustration, provided nothing is otherwise stated.

Abbreviations

Abbreviation	Definition
rpm	Engine revolutions per minute
ABS	Anti-lock brake system
AG	Automatic gearbox
AGM	Vehicle battery type
TCS	Traction control
CO ₂	Carbon dioxide
DPF	Diesel particle filter
DSG	Automatic double clutch gearbox
EDL	electronic differential lock
ECE	Economic Commission for Europe
EPC	EPC fault light
ESC	Electronic Stability Control
D	Rim depth
EU	European Union
GSM	Global System for Mobile communications
HBA	Hydraulic brake assist
HHC	Uphill start assist
kW	Kilowatt, measuring unit for the engine output
MDI	Inputs for connecting external devices
MFD	Multifunction display
MG	Manual gearbox
N1	Panel van intended exclusively or mainly for the transportation of goods
Nm	Newton meter, measuring unit for the engine torque
PIN	personal identification number
SIM card	a card for the identification of the mobile network operator
TDI CR	Diesel engine with turbocharging and common rail injection system
TSI	Petrol engine with turbocharging and direct injection
VIN	Vehicle identification number

Safety

Passive Safety

General information

Introduction

This chapter contains information on the following subjects:

Before setting off _____	8
Driving safety _____	8
Safety equipment _____	8

In this section you will find important information, tips and notes on the subject of passive safety in your vehicle.

We have combined everything here which you should be familiar with, for example, regarding seat belts, airbags, child seats and safety of children.

WARNING

- This chapter contains important information on how to use the vehicle for the driver and his occupants.
- You can find further information on safety concerning you and those travelling with you in the following chapters of this owner's manual.
- The complete on-board literature should always be in the vehicle. This applies in particular, if you rent out or sell the vehicle.

Before setting off

 **Read and observe  on page 8 first.**

For your own safety and the safety of the people travelling with you, please pay attention to the following points before setting off.

- ✓ Ensure that the lighting and the turn signal system are functioning properly.
- ✓ Ensure that the function of the wiper and the condition of the wiper blades are free of any defects.
- ✓ Ensure that all of the windows offer good visibility to the outside.
- ✓ Adjust the rear-view mirror so that vision to the rear is guaranteed.
- ✓ Ensure that the mirrors are not covered.

- ✓ Check the tyre inflation pressure.
- ✓ Check the engine oil, brake fluid and coolant level.
- ✓ Secure all items of luggage.
- ✓ Do not exceed the permissible axle loads and permissible gross weight of the vehicle.
- ✓ Close all doors as well as the bonnet and boot lid.
- ✓ Ensure that no objects can obstruct the pedals.
- ✓ Protect children in suitable child seats with correctly fastened seat belts » [page 22](#), *Transporting children safely*.
- ✓ Adopt the correct seated position » [page 9](#), *Correct and safe seated position*. Tell your passengers to assume the correct seated position.

Driving safety

 **Read and observe  on page 8 first.**

The driver is fully responsible for himself and his occupants. If your driving safety is effected, you place yourself and the oncoming traffic at risk.

The following guidelines must therefore be observed.

- ✓ Do not become distracted from concentrating on the traffic situation, e.g. by your passengers or mobile phone calls.
- ✓ Never drive when your driving ability is impaired, e.g. due to medication, alcohol or drugs.
- ✓ Keep to the traffic regulations and the permissible speed limit.
- ✓ Always adjust the driving speed to the road, traffic and weather conditions.
- ✓ Take regular breaks on long journeys - at least every two hours.

Safety equipment

 **Read and observe  on page 8 first.**

The following list contains only part of the safety equipment in your vehicle.

- Three-point seat belts for all the seats.
- Belt force limiters for the front seats.
- Belt tensioners for the front seats.
- Seat belt height adjusters for the front seats.
- Front airbag for the driver and the front passenger.
- Side airbags.

- › Head airbags.
- › Anchoring points for child seats using the ISOFIX system.
- › Anchoring points for child seats using the TOP TETHER system.
- › Head restraints adjustable for height.
- › Adjustable steering column.

The specified safety equipment works together, in order to optimally protect you and those travelling with you in accident situations.

The safety equipment does not protect you or the people travelling with you, if you or your occupants adopt an incorrect seated position or the equipment is not correctly adjusted or used.

If the seat belt is not fastened properly, this may result in injuries if an airbag is activated in the event of an accident.

Correct and safe seated position

Introduction

This chapter contains information on the following subjects:

Correct seated position for the driver	9
Adjusting the steering wheel position	10
Correct seated position for the front passenger	10
Correct seated position for the passengers in the rear seats	11
Examples of incorrect seated positions	11

! WARNING

- The front seats and all head restraints must be adjusted to match the body size at all times and the seat belt must always be fastened properly to provide the most effective levels of protection to the passengers.
- Each occupant must correctly fasten the seat belt belonging to the seat. Children must be fastened » [page 22](#), *Transporting children safely* with a suitable restraint system.
- If the occupant adopts an incorrect seated position, he is exposed to life-threatening injuries, in case he is hit by a deployed airbag.
- If the occupants on the rear seats are not sitting upright, the risk of injury is increased due to incorrect routing of the seat belt.
- The seat backrests must not be tilted too far back when driving, as this will impair the function of the seat belts and of the airbag system – risk of injury!

Correct seated position for the driver

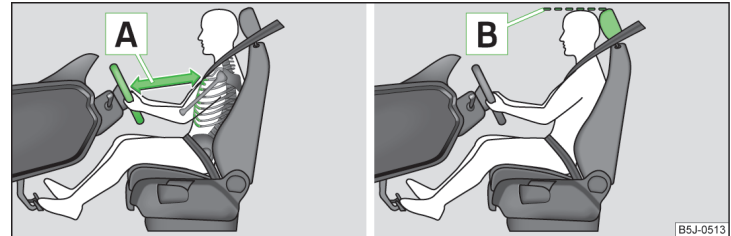

Fig. 1 The correct distance of the driver to the steering wheel/correctly adjusted head restraint

Read and observe **!** on page 9 first.

For your own safety and to reduce the risk of injury in the event of an accident, the following instructions must be observed.

- ✓ Adjust the driver's seat in the forward/back direction so that the pedals can be fully depressed with slightly bent legs.
- ✓ Adjust the seat backrest so that the highest point of the steering wheel can be reached with your arms at a slight angle.
- ✓ Adjust the steering wheel so that the distance **A** between the steering wheel and your chest is at least 25 cm » [Fig. 1](#). Adjust the steering wheel » [page 10](#), *Adjusting the steering wheel position*.
- ✓ Adjust the head restraint such that the top edge of the head restraint is at the same level as the upper part of your head **B**.
- ✓ Correctly fasten the seat belt » [page 12](#), *Using seat belts*.

Adjust the seats and head restraints » [page 69](#).

! WARNING

- Always assume the correct seated position before setting off and do not change this position while driving. Also advise your passengers to adopt the correct seated position and not to change this position while the car is moving.
- Maintain a distance of at least 25 cm from the steering wheel, and a distance of at least 10 cm between the legs and the dash panel at the height of the knee airbag. Not keeping to this minimum distance will mean that the airbag system will not be able to properly protect you – risk of death!
- When driving, hold the steering wheel with both hands firmly on the outer edge in the “9 o'clock” and “3 o'clock” position. Never hold the steering wheel in the “12 o'clock” position or in any other way (e.g. in the middle or inner edge of the steering wheel). In such cases, you could severely injure your arms, hands and head when the driver airbag is deployed.
- Ensure that there are no objects in the driver's footwell, as these may get caught in the pedal apparatus when driving or braking. You would then no longer be able to operate the clutch, brake or acceleration pedals.

Adjusting the steering wheel position

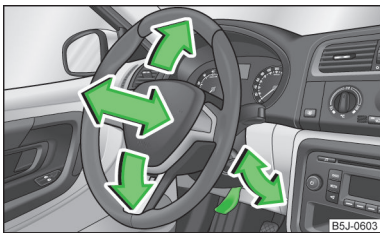

Fig. 2
Adjustable steering wheel: Lever underneath the steering wheel

! Read and observe ! on page 9 first.

The height and forward/back position of the steering wheel can be adjusted.

- Swivel the lever underneath the steering wheel downwards » Fig. 2.
- Adjust the steering wheel to the desired position.
- Push the lever upwards to the stop.

! WARNING

- The lever for adjusting the steering wheel must be locked while you are driving so that the position of the steering wheel cannot accidentally change during the journey – there is the risk of an accident!
- Never adjust the steering wheel when the vehicle is moving only when the vehicle is stationary!

Correct seated position for the front passenger

! Read and observe ! on page 9 first.

For passenger safety and to reduce the risk of injury in an accident, the following instructions must be observed.

- ✓ Position the front passenger seat back as far as possible. The front passenger must maintain a distance of at least 25 cm to the dash panel so that the airbag offers the greatest possible safety if it is deployed.
- ✓ Adjust the head restraint such that the top edge of the head restraint is at the same level as the upper part of your head **B** » Fig. 1 on page 9 » page 9.
- ✓ Correctly fasten the seat belt » page 12.

Adjust the seats and head restraints » page 69.

In exceptional cases the front passenger airbag can be deactivated » page 20, *Deactivating airbags*.

! WARNING

- Maintain a distance of at least 25 cm to the dash panel. Not keeping to this minimum distance will mean that the airbag system will not be able to properly protect you – risk of death!
- Always keep your feet in the footwell when the car is being driven – never place your feet on the instrument panel, out of the window or on the surfaces of the seats. You will be exposed to increased risk of injury if it becomes necessary to apply the brake or in the event of an accident. If an airbag is deployed, you could suffer fatal injuries by adopting an incorrect seated position!

Correct seated position for the passengers in the rear seats

 Read and observe  on page 9 first.

To reduce the risk of injury in the event of a sudden braking manoeuvre or an accident, the occupants on the rear seats must observe the following.

- ✓ Adjust the head restraint such that the top edge of the head restraint is at the same level as the upper part of the head  » Fig. 1 on page 9 » page 9.
- ✓ Correctly fasten the seat belt » page 12, *Using seat belts*.
- ✓ Use a suitable child restraint system if transporting children in the vehicle » page 22, *Transporting children safely*.

Adjust the seats and head restraints » page 69.

Examples of incorrect seated positions

 Read and observe  on page 9 first.

Maximum seat belt protection is only achieved if seat belts are fastened correctly.

Incorrect seated positions considerably reduce the protective functions of the seat belts and therefore increase the risk of injury due to an incorrect routing of the seat belt.

The driver is fully responsible for himself and passengers, especially children. Never allow a passenger to adopt an incorrect seated position when the car is moving.

The following list contains instructions which, if not observed, may cause serious injuries or death. This list is not complete, however we would like you to familiarise yourself with this subject.

Observe the following instructions while driving.

- ✓ Do not stand up.
- ✓ Do not stand on the seats.
- ✓ Do not kneel on the seats.
- ✓ Do not tilt the seat backrest too far back.
- ✓ Do not lean against the dash panel.
- ✓ Do not lie on the rear seats.
- ✓ Do not sit only on the front part of the seat.
- ✓ Do not sit facing to the side.

- ✓ Do not lean out of the window.
- ✓ Do not put your feet out of the window.
- ✓ Do not put your feet on the dash panel.
- ✓ Do not put your feet on the seat cushion.
- ✓ Do not allow anybody to travel in the footwell.
- ✓ Do not drive without fastening your seat belt.
- ✓ Do not delay in the luggage compartment.

Seat belts

Using seat belts

Introduction

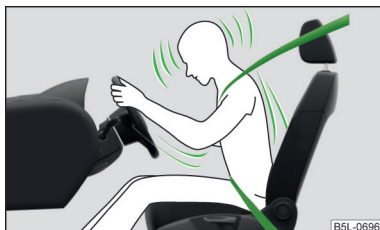

Fig. 3
Driver wearing seat belt

This chapter contains information on the following subjects:

The physical principle of a frontal collision	13
Fastening and unfastening seat belts	14
Belt height adjustment on the front seats	15
Seat belt for the rear middle seat	15

Seat belts that are fastened correctly offer good protection in the event of an accident. They reduce the risk of an injury and increase the chance of survival in the event of a major accident.

Correctly fastened seat belts hold occupants of the car in the correct seated position » Fig. 3.

The seat belts reduce the kinetic energy (energy of motion) to a considerable extent. They also prevent uncontrolled movements which, in turn, may well result in severe injuries.

Occupants of a vehicle who have correctly fastened their seat belts have the major benefit of the fact that the kinetic energy is absorbed as effectively as possible by the belts.

The structure of the front end of the vehicle and other passive safety measures, such as the airbag system, also contribute to the kinetic energy being reduced as effectively as possible. The energy produced is thus absorbed and there is less risk of injury.

Particular safety aspects must be observed when transporting children in the vehicle » page 22, *Transporting children safely*.

! WARNING

- Fasten your seat belt before each journey - even when driving in town! This also applies to the passengers seated at the rear - risk of injury!
- Expectant women must also always wear a seat belt. This is the only way of ensuring optimal protection for the unborn child » page 14, *Fastening and unfastening seat belts*.
- Maximum seat belt protection is only achieved if you are correctly seated » page 9, *Correct and safe seated position*.
- The seat backrests of the front seats must not be tilted too far to the rear otherwise the seatbelts can lose their effectiveness.

! WARNING

Information on the correct routing of the belt

- Always ensure that the webbing of the seat belts is properly routed. Seat belts which are not correctly adjusted can themselves cause injuries even in minor accidents.
- Adjust the height of the belt in such a way that the shoulder part of the belt is roughly positioned across the middle of your shoulder - on no account across your neck.
- A seat belt which is hanging too loose can result in injuries as your body is moved forward by the kinetic energy produced in an accident and is then suddenly held firm by the belt.
- The belt webbing must not run across solid or fragile objects (e.g. spectacles, ball-point pens, bunches of keys etc.). Such objects can cause injury.

! WARNING

Information on dealing with the safety belts

- The belt webbing must not be jammed in-between at any point or twisted, or chafe against any sharp edges.
- Make sure you do not catch the seat belt when closing the door.

! WARNING

Information on the proper use of the safety belts

- Never use one seat belt to secure two persons (including children). The seatbelt must not be placed over a child who is sitting on the lap of another passenger.

! WARNING (Continued)

- The lock tongue should only be inserted into the lock which is the correct one for your seat. Wrong use of the safety belt will reduce its capacity to protect and the risk of injury increases.
- The slot of the belt tongue must not be blocked, otherwise the belt tongue will not lock in place properly.
- Many layers of clothing and loose clothing (e. g. a winter coat over a jacket) do not allow you to be correctly seated and impairs proper operation of the seat belts.
- Do not use clamps or similar items, which prevent the lash lock function of the safety belt from operating. A seat belt which is hanging too loose can result in injuries as your body is moved forward by the kinetic energy produced in an accident and is then suddenly held firm by the belt.
- The seat belts for the rear seats can only fulfil their function reliably when the seat backrests are correctly locked into position » [page 71](#).

! WARNING

Information on the care and maintenance of the safety belts

- The belt webbing must always be kept clean. Soiled belts may impair proper operation of the inertia reel » [page 141](#), *Seat belts*.
- The seat belts must not be removed or changed in any way. Do not attempt to repair the seat belts yourself.
- Check the condition of all the seat belts on a regular basis. If any damage to the seat belts, seat belt connections, inertia reel or the lock is detected, the relevant seat belt must be replaced by a specialist garage.
- Damaged seat belts which have been subjected to stress in an accident and were therefore stretched, must be replaced - this is best done by a specialist garage. The anchorage points of the belts must also be inspected. The anchorage points for the belts should also be checked.

i Note

The national legal requirements must be observed when using seat belts.

The physical principle of a frontal collision

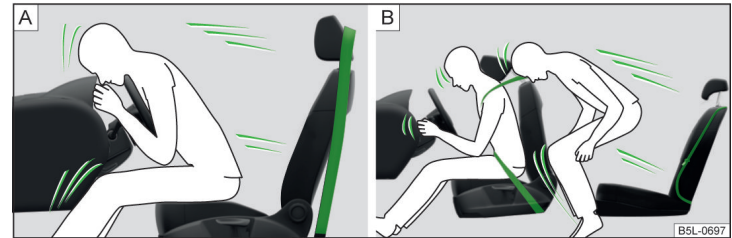

Fig. 4 Driver without a fastened seat belt/rear seat passenger without a fastened seat belt

📖 Read and observe ! on page 12 first.

As soon as the vehicle is moving, so-called kinetic energy (the energy of motion) is produced both in terms of the car as well as in terms of the occupants.

The magnitude of this kinetic energy depends essentially on the speed at which the vehicle is travelling and on the weight of the vehicle including the occupants. The greater the speed and weight increase, the greater the amount of energy which has to be absorbed in the event of an accident.

The speed of the vehicle is the most important factor. Doubling the speed of the vehicle from 25 km/h up to 50 km/hour increases the kinetic energy four times.

The idea that it is possible to support your body with your hands in a minor accident is incorrect. Even in a collision at only a low speed, the forces acting on the body are such that it is no longer possible to support your body.

Even if you only drive at a speed of 30-50 km/h, the forces that your body is exposed to in the event of an accident can exceed a metric ton (1000 kg).

For example, a person's weight of 80 kg "increases" to 4.8 tons (4800 kg) at 50 km/h.

In the event of a frontal collision, occupants of the car not wearing a seat belt are thrown forward and strike parts of the interior of the car, such as the steering wheel, dash panel, windscreen in ways which cannot be controlled » [Fig. 4 - A](#). In certain circumstances you could even be thrown out of the vehicle, which could cause life threatening or even fatal injuries. ▶

It is also important that rear passengers fasten their seat belts, as they could otherwise be thrown through the vehicle in an uncontrolled manner in the event of an accident.

A rear seat passenger who has not fastened the seat belt is a danger not only to himself but also for those seated in the front » Fig. 4 - B.

Fastening and unfastening seat belts

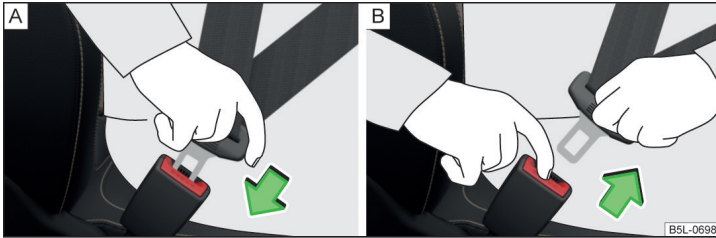

Fig. 5 Fastening/unfastening the seat belt



Fig. 6 Routing of belt webbing over the shoulders and the lap belt/Routing of belt webbing for an expectant mother

Read and observe **I** on page 12 first.

Fastening

- › Correctly adjust the front seat and head restraint before fastening the seat belt » page 72.
- › Use the lock tongue to slowly pull the webbing over your chest and pelvis.

- › Insert the lock tongue into the belt buckle belonging to the seat » Fig. 5 - A until it you hear it click into place.
- › Pull on the belt to check that it has engaged correctly in the lock.

A plastic knob in the belt webbing holds the belt tongue in a position which is easy to get hold of.

It is important that the belt is properly routed to ensure seat belts offer the maximum protection.

The shoulder part of the seat belt must never run across the neck but must roughly run over the middle of the shoulder and fit snugly against the chest. The lap part of the belt must run across the pelvis, must not lie across the stomach and must always fit snugly » Fig. 6 - C.

Expectant women must also always wear a seat belt. This is the only way of ensuring optimal protection for the unborn child.

The lap part of the belt must be positioned as low as possible on the pelvis on expectant mothers to avoid exerting any pressure on the lower abdomen » Fig. 6 - D.

Release

Release the seat belt only when the vehicle is stationary.

- › Press the red button in the belt buckle » Fig. 5 - B, the lock tongue pops out.
- › Manually guide the belt back so that it is easier to fully roll up the webbing, the seat belt does not twist.

! CAUTION

When releasing the seatbelt ensure that the tongue of the lock does not damage the door trim or other parts of the interior.

Belt height adjustment on the front seats

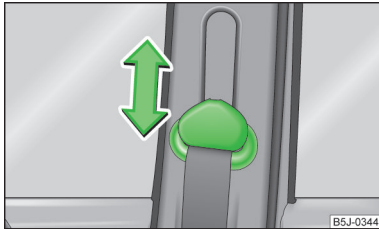

Fig. 7
Front seat: Seat belt height adjuster

Read and observe **!** on page 12 first.

The seat belt height adjuster makes it possible to adjust the routing of the front seat belts in the area of the shoulder to the body size.

- › Press the height adjuster and move up or down in the desired direction » Fig. 7.
- › Then pull firmly on the belt to ensure that the seat belt height adjuster has correctly locked in place.

Seat belt for the rear middle seat

Read and observe **!** on page 12 first.

The seat belt for the rear middle seat is anchored in the area of the boot on the left side of the headliner.

Fastening

- › Pull the belt with both lock tongues out of the headliner mount.
- › Insert the lock tongue at the end of the belt into the belt buckle on the left side until it is heard to lock in place.
- › Pull the second lock tongue, which is moveable on the seat belt, over the chest and insert it into the belt buckle on the right side until it is heard to lock in place.
- › Pull on the seat belt to check that both lock tongues are securely engaged in the locks.

The belt tongues for the rear middle seat are shaped differently so that they only fit into the correct belt buckle. If you are not able to insert a lock tongue into the wrong belt lock you probably tried to put it into the wrong buckle.

Release

- › Take off the safety belt in the reverse order to how you fasten it.
- › Guide the belt back by hand so that the webbing rolls up easily, the seat belt is not twisted and the trim panel is not damaged.

! WARNING

- After releasing the seat belt, hold it tight and let it slowly reel up until both locking tongues lock into the headliner mounting and are secured with a magnet - risk of injury.
- Never unlock both lock tongues simultaneously.

Inertia reels and belt tensioners

Introduction

This chapter contains information on the following subjects:

Inertia reels	15
Belt tensioners	15

Inertia reels

Each seat belt is equipped with an inertia reel.

When pulling slowly on the seat belt, the belt can move freely. When pulling sharply on the seat belt, the movement is locked by the inertia reel.

The belts also lock when full braking, when the car accelerates, when driving downhill and when cornering.

! WARNING

If the seat belt does not lock when pulling sharply on it, have it inspected immediately by a specialist garage.

Belt tensioners

Safety for the driver and front passenger **wearing their seat belts** is enhanced by the belt tensioners fitted to the inertia reels of the front three-point seat belts.

The three-point seat belts are automatically tensioned in the event of a frontal collision of a certain severity. The belt tensioners can also be deployed if the seat belts are not fastened. ▶

The seat belts are automatically tensioned in the event of a collision of a certain severity.

Belt tensioners are not activated in the event of minor frontal collisions, side and rear-end collisions, in the case of a rollover and also not in accidents in which no major forces are produced from the front.

WARNING

- Any work on the belt tensioner system including removal and installation of system components because of other repair work, must only be carried out by a specialist garage.
- The protective function of the system is only adequate for a single accident. If the belt tensioners have been deployed, it is then necessary to replace the entire system.

Note

- Smoke is generated when the belt tensioners are deployed. This is not an indication of a fire in the vehicle.
- When disposing of the vehicle or parts of the belt tensioner system, it is important to comply with national legal requirements. ŠKODA service partners are familiar with these regulations and will be able to provide you with detailed information.

Airbag system

Description of the airbag system

Introduction

This chapter contains information on the following subjects:

System description	_____	17
Airbag deployment	_____	17

The airbag system provides, as a supplement to the seat belts, additional occupant protection during severe frontal and side collisions.

WARNING

- **An airbag can only offer you optimal protection in combination with a fastened seat belt.**
- The airbag is not a substitute for the seat belt, but instead forms part of the complete passive vehicle safety concept.
- To ensure passengers are protected with the greatest possible effect when the airbag is deployed, the front seats must be correctly adjusted to match the body size » [page 9](#), *Correct and safe seated position*.
- If you do not fasten the seat belts when driving, lean too far forward or adopt an incorrect seated position, you are exposing yourself to increased risk of injury in the event of an accident.

WARNING

Information on the use of the airbag system

- If there is a fault, the airbag system must be checked by a specialist garage immediately. Otherwise, there is a risk of the airbag not being activated in the event of an accident.
- No modifications of any kind must be made to parts of the airbag system.
- Any work on the airbag system including the installation and removal of system components due to other repair work (e.g. removal of the steering wheel) must only be carried out by a specialist garage.
- Never make any changes to the front bumper or bodywork.
- It is prohibited to manipulate individual parts of the airbag system as this might result in the airbag being deployed.
- The protective function of the airbag system is sufficient for only one accident. The airbag system must then be replaced if the airbag has been deployed.

System description

 **Read and observe**  on page 16 first.

The functional status of the airbag system is indicated by the indicator light  in the instrument cluster » page 44.

When the airbags are deployed, they fill with gas and inflate.

A grey white or red, non-harmful gas is released when the airbag is inflated. This is perfectly normal and is not an indication of a fire in the vehicle.

Depending on the vehicle equipment, the airbag system consists of the following modules.

- › Electronic control unit.
- › Front airbag for the driver and the front passenger » page 18.
- › Side airbags » page 19.
- › Head airbags » page 19.
- › Airbag warning light in the instrument cluster » page 44.
- › Key switch for the front passenger airbag » page 21.
- › Warning light for the front passenger airbag deactivation/activation in the middle of the dash panel » page 21.

Note

- The airbag system needs no maintenance during its working life.
- If you sell your vehicle, provide the complete vehicle documentation to the new owner. Please note that the information relating to the possibility of deactivating the front passenger airbag must be included!
- When disposing of vehicle or parts of the airbag system, it is important to comply with the national legal requirements.

Airbag deployment

 **Read and observe**  on page 16 first.

The airbags inflate in fractions of a second and at a high speed in order to be able to offer additional protection in the event of an accident.

The airbag system is only functional when the ignition is switched on.

In certain accident situations, the several airbags may be deployed simultaneously.

The airbags **are not deployed** in the case of **minor** frontal and side collisions, rear-end collisions, tilting of the vehicle and vehicle rollover.

Deployment factors

It is not possible to generally determine which deployment conditions apply to the airbag system in every situation. An important role is played by factors such as the type of object that the vehicle hits (hard/soft), the impact angle, vehicle speed etc.

A decisive factor for the deployment of the airbags is the deceleration which occurs. The control unit analyses the nature of the collision and activates the relevant restraint system.

If the vehicle deceleration which occurs and is measured during the collision remains below the prescribed reference values specified in the control unit, the airbags are not deployed although the vehicle may well suffer severe damage to the bodywork as a consequence of the accident.

The following airbags will be deployed in the event of a severe frontal collision.

- › Driver's front airbag.
- › Front passenger airbag.

The following airbags will be deployed in the event of a severe side collision.

- › Front side airbag on the side of the accident.
- › Head airbags on the side of the accident.

When an airbag is deployed, the following events occur.

- › The interior lighting comes on (if the switch for the interior light is in the door contact position).
- › The hazard warning lights are switched on.
- › All the doors are unlocked.
- › The fuel supply to the engine is interrupted.

Airbag overview

Introduction

This chapter contains information on the following subjects:

Front airbags	_____	18
Side airbags	_____	19
Head airbags	_____	19

Front airbags

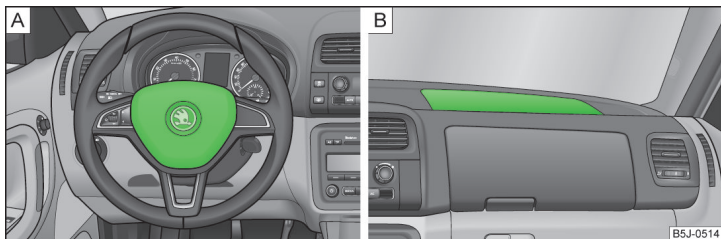

Fig. 8 Driver airbag in the steering wheel/front passenger airbag in the dashboard

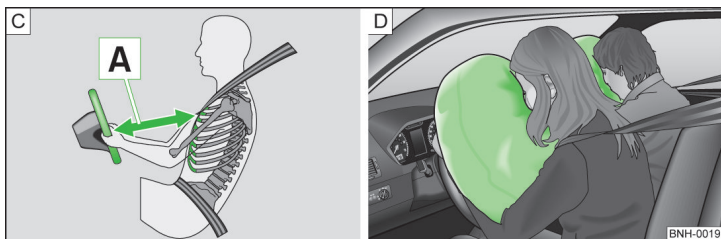

Fig. 9 Safe distance to steering wheel/gas-filled airbags

In the event of a severe frontal collision, the front airbag system offers additional protection for the head and chest area of the driver and front passenger.

The front airbag for the driver is housed in the steering wheel » Fig. 8 - A.

The front airbag for the front seat passenger is located in the dash panel above the glove compartment » Fig. 8 - B.

The airbags inflate in front of the driver and front passenger when they are deployed » Fig. 9 - D. The forward movement of the driver and of the front passenger is cushioned when they make contact with the fully inflated airbag and the risk of injury to head and chest is thus reduced.

! WARNING

Information on correct seated position

- For the driver and front passenger, it is important to maintain a distance of at least 25 cm from the steering wheel or dashboard A » Fig. 9. Not maintaining this minimum distance will mean that the airbag system will not be able to properly protect you - hazard! The front seats and the head restraints must always also be correctly adjusted to match the body size of the occupant.
- The airbag develops enormous forces when triggered, which can lead to injuries if the sitting position or seated position is not correct.
- There must not be any further persons, animals or objects positioned between the front seated occupants and the deployment area of the airbag.

! WARNING

Front airbag and transporting children

- Never transport children on the front seat of a vehicle without using a proper restraint system. If airbags are deployed in the event of an accident, the child might suffer severe or even fatal injuries!
- The front passenger airbag must be deactivated if using a rear-facing child seat on the front passenger seat » page 20, *Deactivating airbags*. If this is not done, there is a risk of the child suffering severe or even fatal injuries if the front passenger airbag is deployed. When transporting a child on the front passenger seat, pay attention to any relevant national regulations regarding the use of child safety seats.

! WARNING

General information

- The steering wheel and the surface of the airbag module in the dash panel on the passenger side must not have stickers attached, be covered or modified in any other way. These parts should only be cleaned with a cloth that is dry or has been moistened with water. No objects such as cup holders, mobile phone mounts, etc. must be attached to the covers of the airbag modules or be located within their immediate vicinity.
- Never place objects on the surface of the front passenger airbag module in the dash panel.

i Note

- In vehicles with head airbags, the lettering **AIRBAG** can be seen on the steering wheel.
- In vehicles with front passenger airbags, the lettering **AIRBAG** is located on the dash panel on the passenger side.

Side airbags

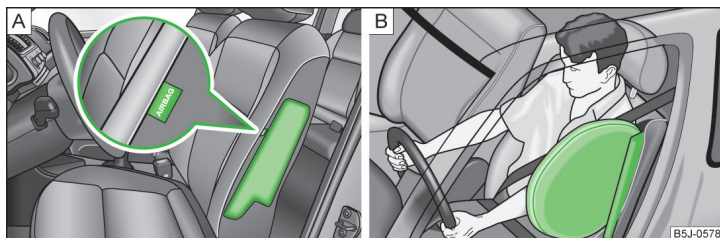

Fig. 10 Location of the side airbag in the driver's seat / gas-filled side airbag

In the event of severe side collisions, the side airbag system provides additional protection for the upper body (chest, stomach and pelvis) of passengers in the vehicle.

The side airbags are housed in the upholstery of the seat backrests of the front seats » Fig. 10 - **A**.

The head airbag and belt tensioner on the relevant side are also automatically deployed when the side airbags » Fig. 10 - **B** are deployed.

The load of the occupants is cushioned when plunging into the fully inflated airbag and the risk of injury to the entire upper body (chest, stomach and pelvis) is reduced on the side facing the door.

! WARNING

Information on correct seated position

- Your head should never be positioned in the deployment area of the side airbag. You might suffer severe injuries in the event of an accident. This applies in particular to children who are transported without using a suitable child safety seat » page 24, *Child safety and side airbag*.

! WARNING (Continued)

- There must not be any further persons, animals or objects positioned between the occupants and the deployment area of the airbag. No accessories, such as cup holders, should be attached to the doors.
- If children adopt an incorrect seated position when travelling, they may be exposed to an increased risk of injury in the event of an accident. This can result in serious injuries » page 22, *Child seat*.

! WARNING

- Ensure that there are no excessive forces, such as violent knocks, kicks etc., impact on the backrests of the seats otherwise the system may be damaged. The side airbags would not be deployed in such a case!
- Any seat or protective covers which you fit to the driver or front passenger seats must only be of the type expressly authorized by ŠKODA. In view of the fact that the airbag inflates out of the backrest of the seat, use of non-approved seat or protective covers would considerably impair the protective function of the side airbag.
- Any damage to the original seat covers in the area of the side airbag module must be repaired immediately by a specialist garage.
- The airbag modules in the front seats must not display any damage, cracks or deep scratches. It is not permissible to use force in order to open the modules.

i Note

In vehicles with side airbags a label with the lettering **AIRBAG** is located on the front seat backrests.

Head airbags

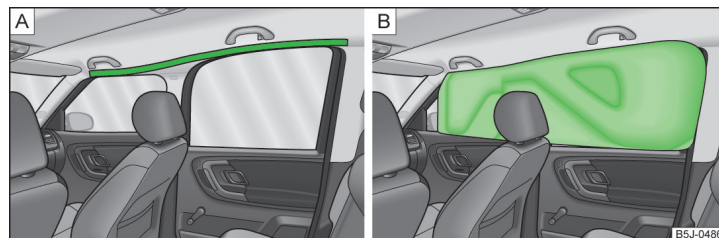

Fig. 11 Location of the head airbag/gas-filled head airbag

In the event of a severe side collision, the head airbag system offers additional protection for the head and neck area of passengers.

The head airbags are positioned above the doors on both sides in the interior of the car » Fig. 11 - A.

In the event of a **side collision** the head airbag is deployed together with the relevant side airbag and the front seat belt tensioner on the side of the car on which the accident occurs.

The airbag covers the windows of the front and rear doors, as well as the door pillar when it is deployed » Fig. 11 - B.

Head impact with interior parts is reduced by the inflated head airbag. The reduction in any impact to the head and the resultant minimizing of any movements of the head additionally reduce the risk of injuries to the neck area.

! WARNING

- There must not be any objects in the deployment area of the head airbags which might prevent the airbags from inflating properly.
- Only hang light items of clothing on the hooks fitted in the vehicle. Never leave any heavy or sharp-edged objects in the pockets of the items of clothing. Additionally, clothes hangers must not be used to hang up items of clothing.
- The installation of impermissible accessories in the vicinity of the head airbags can considerably impair the protection offered by the head airbag in the event of it being deployed. When the deployed head airbag is inflated, parts of the fitted accessories could be thrown into the interior of the car and injure the occupants.
- The sun visors must not be swivelled towards the side windows in the deployment area of the head airbags if any objects, such as ball-point pens, etc. are attached to them. This might result in injuries to the occupants if the head airbag is deployed.
- There must not be any further persons, animals or objects positioned between the seated occupants and the deployment area of the airbag. In addition, none of the occupants should lean their head out of the window when driving, or extend their arms and hands out of the window.

i Note

In vehicles with head airbags, the lettering **AIRBAG** can be seen on the B column cladding.

Deactivating airbags

Introduction

This chapter contains information on the following subjects:

Deactivating airbags _____	20
Deactivating the front passenger airbag _____	21

Deactivating airbags

Deactivating an airbag should be considered in cases such as the ones below.

- If using a rear-facing child seat on the front passenger seat (due to different legal regulations, the airbag must be deactivated if using a forwards-facing child seat in some countries) » page 22, *Transporting children safely*.
- If it is not possible to maintain a distance of at least 25 cm between the middle of the steering wheel and chest, despite the driver's seat being correctly adjusted.
- If special attachments are required in the area of the steering wheel because of a physical disability.
- If different seats have been fitted (e.g. orthopaedic seats without side airbags).

The front passenger airbag can be switched off with the key-operated switch » page 21.

We recommend that you ask a ŠKODA service partner to deactivate any other airbags.



Monitoring the airbag system

The operational capability of the airbag system is monitored electronically, including when one of the airbags is switched off.

Airbag deactivated using diagnostic equipment

- The warning light  lights up for approx. 3 seconds after switching on the ignition and then flashes again for approx. 12 seconds.

Front passenger airbag deactivated using the key switch in the storage compartment

- The warning light  lights up for approx. 3 seconds after switching on the ignition.
- The warning light **OFF**  » Fig. 12 on page 21 - B comes on after the ignition has been switched on.

i Note

- The national regulations for switching off airbags must be observed.
- A ŠKODA service partner will be able to inform you which, if any, of your vehicle's airbags can or must be deactivated.

Deactivating the front passenger airbag

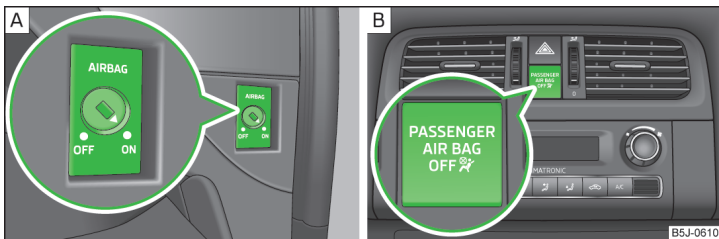

Fig. 12 Key-operated switch for the front passenger airbag / warning light for front seat passenger airbag deactivation

Only the front passenger airbag is deactivated with the key switch.

Switching off

- Switch off the ignition.
- Open the passenger door.
- Fold the key bit out **completely** for the radio key » **!**.
- Carefully insert the key into the key slot in the key switch as far as the stop.
- Use the key to turn the slot of the key switch carefully into the position **OFF** » Fig. 12 - **A**.
- Pull the key out of the slot in the key switch » **!**.
- Close the passenger door.
- Check that the warning light **OFF** under the text **PASSENGER AIR BAG** » Fig. 12 - **B** lights up after the ignition is switched on.

Switching on

- Switch off the ignition.
- Open the passenger door.
- Fold the key bit out **completely** for the radio key » **!**.
- Carefully insert the key into the key slot in the key switch as far as the stop.

- Use the key to turn the slot of the key switch carefully into the position **ON** » Fig. 12 - **A**.
- Pull the key out of the slot in the key switch » **!**.
- Close the passenger door.
- Check that the warning light **OFF** under the text **PASSENGER AIR BAG** » Fig. 12 - **B** lights up after the ignition is switched on.

! WARNING

- The driver is responsible for whether the airbag is switched on or switched off.
- Only switch off the airbag when the ignition is switched off! Otherwise a fault can occur in the system for deactivating the airbag.
- If the warning light **OFF** flashes, then the front passenger airbag will not be deployed in the event of an accident. Have the airbag system checked by a specialist garage immediately.
- The key cannot be inserted in the key switch while driving.
 - Shocks can cause the key to turn in the slot and trigger the airbag!
 - The airbag could be triggered unexpectedly in an accident - it may result in injury or death!

! CAUTION

An insufficiently folded out key bit can damage the key switch!

¹⁾ The warning light **OFF** comes on for a few seconds after the ignition is switched on, goes out for about 1 second and then comes on again.

Transporting children safely

Child seat

Introduction

This chapter contains information on the following subjects:

Use of a child seat on the front passenger seat	23
Use of the child seat in the front passenger seat	24
Child safety and side airbag	24
Classification of child seats	24
Use of child seats fastened with a seat belt	24

Children are generally safer on the rear seats than on the front passenger seat.

In contrast to adults, the muscles and bone structure of children are not yet fully developed. Thus children are exposed to increased risk of injury.

Children should be transported in accordance with the relevant statutory provisions.

Child seats that comply with the ECE-R 44 standard must be used. The ECE-R standard stands for: Economic Commission for Europe - Regulation.

Child seats that comply with the ECE-R 44 standard are identified with a test mark that cannot be removed: a large E within a circle with the test number below.

WARNING

- The national legal requirements must be observed when using child seats.
- One should never carry children, and also not babies! - on one's lap.
- Never leave children unattended in the vehicle. Certain outside climatic conditions can cause life-threatening temperatures in the vehicle.
- The child must be secured in the vehicle during the entire journey! Otherwise, the child would be thrown through the vehicle in the event of an accident, causing fatal injuries to both the child and other occupants.

WARNING (Continued)

- Children are exposed to an increased risk of injury in the event of an accident if they lean forward or adopt an incorrect seated position when the vehicle is moving. This particularly applies to children who are transported on the front passenger seat as they can suffer severe, or even fatal injuries if the airbag system is deployed!
- Pay particular attention to the information provided by the manufacturer of the child safety seat regarding the correct routing of the belt. Seat belts which are not correctly adjusted can themselves cause injuries even in minor accidents.
- Safety belts must be checked to ensure that they are running properly. One should also ensure that the belt is not damaged by sharp-edged fittings.
- The front passenger airbag must be deactivated if using a rear-facing child seat on the front passenger seat. Further information » [page 23](#), *Use of a child seat on the front passenger seat.*

CAUTION

- When installing a child seat in which the child faces forward, adjust the head restraints so that they are as high as possible.
- If the head restraints still prevent the child seat from being installed, even in the highest position, you will need to remove them » [page 73](#). After removing the child seat, re-install the head restraints.

Note

We recommend that you use child seats from ŠKODA Original Accessories. These child seats were developed and also tested for use in ŠKODA vehicles. They meet the ECE-R 44 standard.

Use of a child seat on the front passenger seat

Does not apply to Taiwan

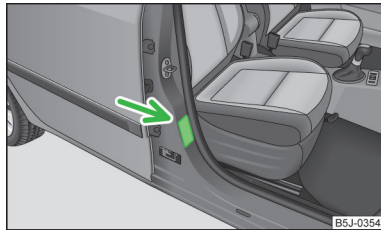

Fig. 13
Sticker on the B column on the front passenger side.



Fig. 14 Front passenger sun visor / sticker

Read and observe  and  on page 22 first.

Never use a rearward-facing child restraint system on a seat which is protected by an active airbag installed in front of it. This could cause serious injury to the child, even death.

For safety reasons, we recommend that you install child seats on the rear seats whenever possible.

The following instructions must be followed when using a child seat on the front passenger seat.

- The front passenger airbag must be deactivated if using a rear-facing child seat » .
- If possible, adjust the front passenger seat backrest so that it is as vertical, so as to ensure secure contact between the passenger seat backrest and the back of the child seat.

- If possible, move the front passenger seat backwards so that there is no contact between the front passenger seat and the child seat behind it.
- With child safety seats in groups 2 or 3, make sure that the loop-around fittings attached to the child seat headrest is positioned in front of or at the same height as the loop-around fittings on the B pillar on the passenger side.
- Set the height-adjustable front passenger seat as high up as possible.
- Set the front passenger seat belt as high up as possible.
- Place and fasten the child seat on the seat and the child in the child seat according to the specifications in the manufacturer's user manual of the child seat.

WARNING

- The front passenger airbag must be deactivated if using a rear-facing child seat on the front passenger seat » [page 20, Deactivating airbags](#).
- **Never** use a rear-facing child seat on the front passenger seat if the passenger airbag is activated. This child safety seat is positioned in the deployment area of the front passenger airbag. The airbag may cause the child severe, or even fatal injuries, in the event of it being deployed.
- This fact is also indicated by the sticker that can be found in one of the following locations.
 - On the B-column on the front passenger side » [Fig. 13](#). The sticker is visible upon opening the front passenger door.
 - On the front passenger's sun visor. In some countries, the sticker is located on the front passenger's sun visor » [Fig. 14](#).
- With child safety seats in groups 2 or 3, make sure that the loop-around fittings attached to the child seat headrest is positioned in front of or at the same height as the loop-around fittings on the B pillar on the passenger side.
- As soon as the rear-facing child seat is no longer being used on the passenger seat, the front passenger airbag should be re-activated again.

Use of the child seat in the front passenger seat

Applies to Taiwan



Fig. 15 Front passenger sun visor / label

Read and observe **!** and **!** on page 22 first.

No babies, infants or children are to be carried on the passenger seat.

This fact is also indicated by the label that can be found on the passenger's sun visor » Fig. 15.

Child safety and side airbag



Fig. 16
Incorrect seated position of a child who is not properly secured - risk from the side airbag/Child properly protected by safety seat

Read and observe **!** and **!** on page 22 first.

The child must not be positioned in the area into which the side airbag will deploy » Fig. 16 - [A].

There must be sufficient room between the child and the area into which the side airbag will deploy to allow the airbag to provide as much protection as possible » Fig. 16 - [B].

! WARNING

- Children must never be seated with their head in the deployment area of the side airbag - risk of injury!
- Do not place any objects within the deployment area of the side airbags - risk of injury!

Classification of child seats

Read and observe **!** and **!** on page 22 first.

Classification of child seats according to the ECE-R 44 standard.

Group	Weight of the child	Approximate age
0	up to 10 kg	up to 9 months
0	up to 13 kg	up to 18 months
1	9-18 kg	up to 4 years
2	15-25 kg	up to 7 years
3	22-36 kg	over 7 years

Use of child seats fastened with a seat belt

Read and observe **!** and **!** on page 22 first.

Overview of the usability of child seats fastened with a seat belt on each of the seats in accordance with the ECE-R 16 standard.

Group	Front passenger seat	Rear seats external	Rear seat Center
0 up to 10 kg	U	U	U
0+ up to 13 kg	U	U	U
1 9-18 kg	U	U	U
2 15-25 kg	U	U	U
3 22-36 kg	U	U	U

U Child seat category "Universal" - a child seat designed to be attached to the seat using the seat belt.

Fastening systems

Introduction

This chapter contains information on the following subjects:

Attachment points of the **ISOFIX**-system _____ 25

Use of child seats with the **ISOFIX**-system _____ 25

Attachment points of the **TOP TETHER**-system _____ 26

Attachment points of the **ISOFIX**-system



Fig. 17
ISOFIX system label

ISOFIX represents a system for a fast and secure child seat mounting.

There are two locking eyes between the rear exterior seats for fixing the child seat in place, using the **ISOFIX**-system.

The places are marked with labels with the **ISOFIX** logo » Fig. 17.

! WARNING

- Always refer to the instructions from the manufacturer of the child seat when installing and removing a child seat with the **ISOFIX**-system.
- Never attach other child seats, belts or objects to the attachment points eyes intended for the installation of a child seat with the **ISOFIX**-system - risk of death!

i Note

- A child seat fitted with the **ISOFIX**-system can only be mounted in a vehicle fitted with an **ISOFIX**-system if the child seat has been approved for this type of vehicle. Further information is available from a ŠKODA Partner.
- Child seats with the **ISOFIX**-system can be purchased from ŠKODA Original Accessories.

Use of child seats with the **ISOFIX**-system

Overview of the usefulness of child seats fastened with the **ISOFIX**-system on each of the seats in accordance with the ECE-R 16 standard.

Group	Size class of the child seat ⁹⁾	Front passenger seat	Outer rear seats	Rear seat middle
0 up to 10 kg	E	X	IL-SU	X
0+ up to 13 kg	E	X	IL-SU	X
	D			
	C			

Group	Size class of the child seat ^{a)}	Front passenger seat	Outer rear seats	Rear seat middle
1 9-18 kg	D	X	IL-SU IUF	X
	C			
	B			
	B1			
	A			
2 15-25 kg		X	IL-SU	X
3 22-36 kg		X	IL-SU	X

^{a)} The size category is shown on the label attached to the child seat.

IL-SU The seat is suited for installation of a **ISOFIX**-child seat with the "Semi-Universal" approval. The "Semi-Universal" category means that the child seat with the **ISOFIX**-system is approved for your vehicle. Observe the list of vehicles that comes with the child seat.

IUF The seat is suitable for the installation of a **ISOFIX**-child seat with the approval "Universal" and attachment with the **TOP TETHER**-system belt.

X The seat is not fitted with **ISOFIX**-system attachment points.

! WARNING

- Always refer to the instructions from the manufacturer of the child seat when installing and removing a child seat with the **TOP TETHER**-system.
- Only use child seats with the **TOP TETHER**-system on the seats with the locking eyes.
- Only ever attach one belt from the child seat to a locking eye.
- On no account should you equip your vehicle, e.g. mount screws or other anchorage points.

Attachment points of the **TOP TETHER**-system

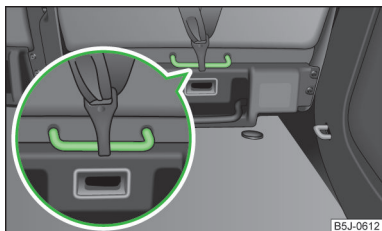

Fig. 18
The attachment point of the **TOP TETHER**-system

TOP TETHER represents a fastening system, which restricts movements of the upper part of the child seat.

The anchor eyelets for attaching the belt for a child seat with the **TOP TETHER**-system are located on the rear side of the outer rear seat backrests » Fig. 18.

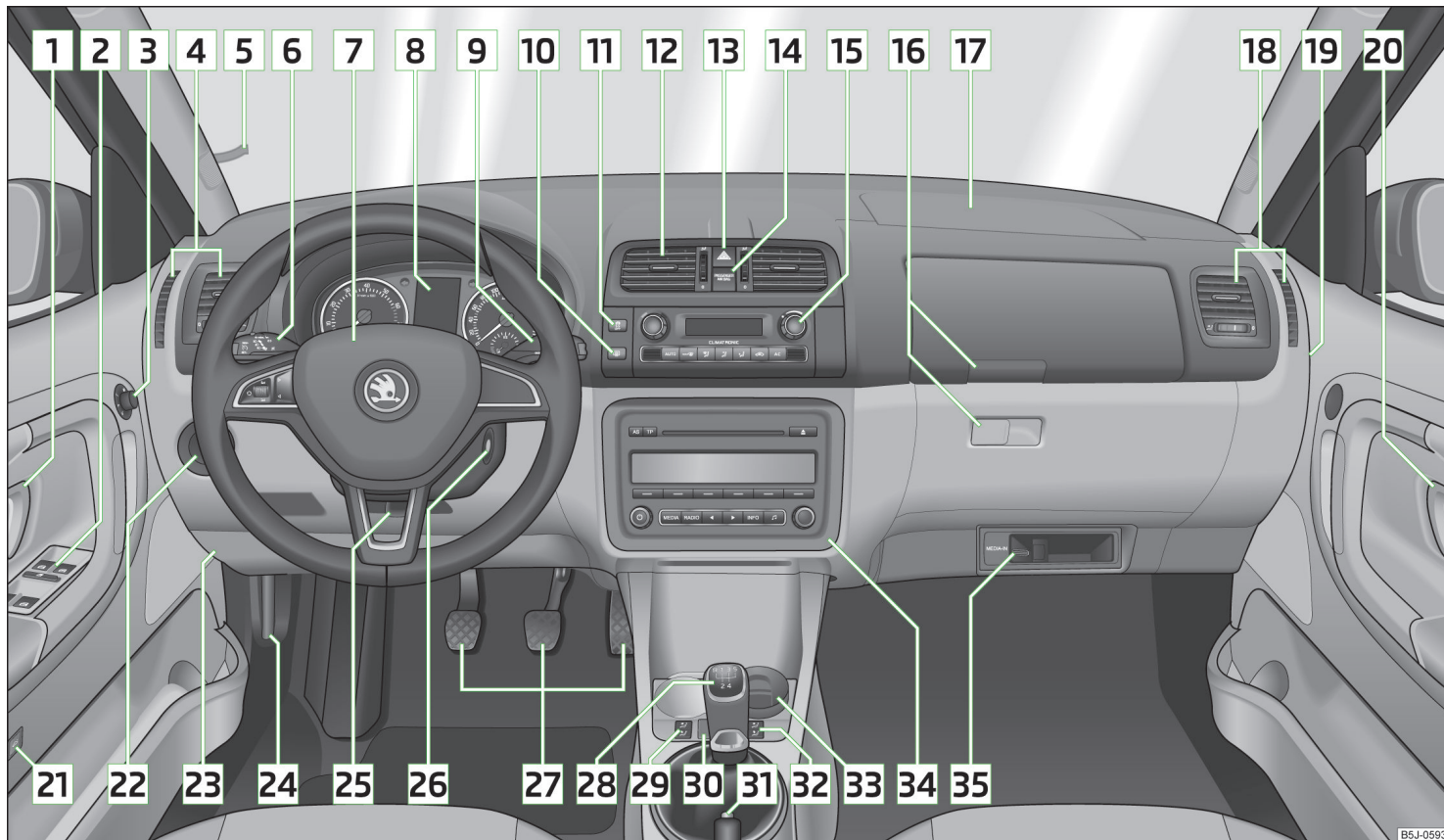

Fig. 19 Cockpit

B5J-0593

Operation

Cockpit

Overview

1	Door opening lever	48
2	Electrical power windows	55
3	Electric exterior mirror adjustment	68
4	Air outlet vents	90
5	Parking ticket holder	83
6	Operating lever: <ul style="list-style-type: none">> Turn signal light, headlight and parking light, headlight flasher> Speed regulating system	61 121
7	Steering wheel: <ul style="list-style-type: none">> With horn> With driver's front airbag> With pushbuttons for radio, navigation system and mobile phone	18 97
8	Instrument cluster: Instruments and warning lights	30
9	Operating lever: <ul style="list-style-type: none">> Windscreen wiper and wash system> Multifunction display> MAXI DOT display	66 33 37
10	Button for rear window heater	64
11	TCS button	120
12	Air outlets in the central part of the dash panel	90
13	Button for hazard warning light system	63
14	Warning light for the deactivated front seat passenger airbag	21
15	Depending on equipment fitted: <ul style="list-style-type: none">> Operating controls for the heating> Operating controls for the air conditioning system> Operating controls for Climatronic	91 93 95
16	Storage compartments on the front passenger side	84
17	Front passenger airbag	18
18	Air outlet vents	90
19	Key-operated switch for the front seat passenger airbag	21
20	Door opening lever	48
21	Switch depending on equipment fitted: <ul style="list-style-type: none">> Boot lid remote release> Interior monitor	55 54
22	Light switch and headlamp beam adjustment	59, 60
23	Fuse box in the dashboard	176
24	Bonnet release lever	146
25	Lever for adjusting the steering wheel	10
26	Ignition lock	107
27	Pedals	109
28	Depending on equipment fitted: <ul style="list-style-type: none">> Gearshift lever (manual gearbox)> Selector lever (automatic gearbox)	109 110
29	Rocker switch for front left seat heating	69
30	Central locking system	51
31	Handbrake	109
32	Rocker switch for front right seat heating	69
33	Depending on equipment fitted: <ul style="list-style-type: none">> Ashtrays> Storage compartment	81 85
34	Depending on equipment fitted: <ul style="list-style-type: none">> Radio> Navigation system	
35	MDI	104

i Note

The arrangement of the controls right-hand drive models may differ from the layout shown in » Fig. 19. The symbols on the controls and switches are the same as for left-hand drive models.

Instruments and Indicator Lights

Instrument cluster

Introduction

This chapter contains information on the following subjects:

Overview	30
Engine revolutions counter	31
Speedometer	31
Coolant temperature gauge display	31
Fuel gauge	31
Counter for distance driven	32
Digital clock	32
Display of the second speed	32
Recommended gear	32

Fault display

The **Error** message will appear in the display if there is a fault in the instrument cluster. Ensure that the fault is rectified as soon as possible by a specialist workshop.

! WARNING

- Concentrate fully at all times on your driving! As the driver you are fully responsible for road safety.
- Never operate the controls in the instrument cluster while driving, only when the vehicle is stationary!

Overview

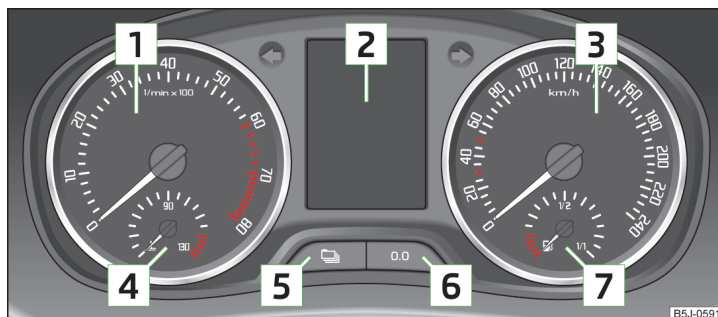

Fig. 20 Instrument cluster

📖 Read and observe **!** on page 30 first.

- 1 Revolutions counter with warning lights » page 31
- 2 Display:
 - With counter for distance driven » page 32
 - With service interval display » page 36
 - With digital clock » page 32
 - With multifunction display (MFA) » page 33
 - With the MAXI DOT display » page 37
- 3 Speedometer with warning lights » page 31
- 4 Coolant temperature gauge¹⁾ » page 31
- 5 Button for display mode:
 - Setting the hours/minutes » page 32
 - Enable/disable the display of the second speed²⁾ » page 32
 - Service interval²⁾ - Display of the number of days, kilometres or miles remaining until the next Service³⁾ » page 36

¹⁾ Applies for vehicles using the MAXI DOT display.

²⁾ Applies for vehicles with a segment display.

³⁾ Applies for models in which where the values are indicated in British measuring units.

- 6 Button for:
 - Reset trip meter » page 32
 - Set hours/minutes
 - Enable/disable the mode selected by means of button 5
- 7 Fuel gauge¹⁾ » page 31

Engine revolutions counter

📖 Read and observe  on page 30 first.

The red scale range of the rev counter 1 » Fig. 20 on page 30 indicates the range in which the engine control unit begins to limit the engine speed. The engine control unit restricts the engine speed to a steady limit.

You should shift into the next higher gear before the red scale of the revolution counter is reached, or move the selector lever into position D if your car is fitted with an automatic gearbox.

To maintain the optimum motor speed, observe the gearshift indicator » page 32.

For the sake of the environment

Shifting up in good time has the following benefits.

- It helps to reduce fuel consumption.
- It reduces engine noise.
- It protects the environment.
- It benefits the life and reliability of the engine.

Speedometer

📖 Read and observe  on page 30 first.



Warning against speeding

An audible warning will sound when the vehicle speed exceeds 120 km/h²⁾. The audible warning is switched off once the vehicle speed falls below 120 km/h.

Coolant temperature gauge display

📖 Read and observe  on page 30 first.

The coolant temperature gauge 4 » Fig. 20 on page 30 works only when the ignition is switched on.

In vehicles with a segment display, the coolant temperature is indicated only by one of the warning lights » page 41,   Coolant coming on or going off.

Cold range

The pointer in the left of the scale indicates that the engine has not yet reached its operating temperature. Avoid high speeds, full throttle and high engine loads. This prevents possible damage to the engine.

The operating range

The engine has reached its operating temperature as soon as the pointer moves into the middle of the scale. At very high ambient temperatures or under heavy engine loads, the pointer may move even further to the right.

High temperature range

The coolant temperature is too high if the pointer reaches the red area of the scale. Further information » page 41.

CAUTION

- Additional headlights and other attached components in front of the air inlet impair the cooling efficiency of the coolant.
- Never cover the radiator - there is a risk of the engine overheating.

Fuel gauge

📖 Read and observe  on page 30 first.

The fuel gauge 7 » Fig. 20 on page 30 only works when the ignition is switched on.

The fuel remaining is displayed in the segment display on vehicles with the segment display.

The fuel tank has a capacity of about 55 litres. The warning light lights up when the fuel level reaches the reserve range  » page 44. ▶

¹⁾ Applies for vehicles using the MAXI DOT display.

²⁾ This function is only enabled in certain countries.

! CAUTION

Never drive until the fuel tank is completely empty! The irregular supply of fuel can cause misfiring. This can result in considerable damage to parts of the engine and the exhaust system.

Counter for distance driven

📖 Read and observe ! on page 30 first.

The distance which you have driven with your vehicle is shown in km. In some countries the measuring unit "mile" is used.

Daily trip counter (trip)

The trip counter indicates the distance you have driven since it was last reset - in steps of 100 metres or 1/10 of a mile.

Reset trip meter

The meter can be reset by pressing and holding button **[6]** » Fig. 20 on page 30.

Odometer

The odometer indicates the total distance in kilometres or miles which the vehicle has been driven.

i Note

If the second speed display is enabled on vehicles with a segment display, this speed will be shown instead of the odometer.

Digital clock

📖 Read and observe ! on page 30 first.

The clock is set with buttons **[5]** and **[6]** » Fig. 20 on page 30.

Select the display that you wish to change with the button **[5]** and carry out the change with the button **[6]**.

In vehicles equipped with the MAXI DOT display, it is also possible to set the clock in the Time menu » page 38.

Display of the second speed

📖 Read and observe ! on page 30 first.

The display can show the current speed in mph¹⁾.

This feature is provided for driving in countries with different units for speed.

MAXI DOT display

The display of the second speed can be set in the Settings menu item » page 38, Settings.

Segment display

- Press the **[5]** » Fig. 20 on page 30 key repeatedly, until the odometer display flashes » page 32.
- Press the **[6]** key while the display is flashing.

The second speed is displayed instead of the odometer.

Display of the second speed can be disabled in the same way.

Recommended gear

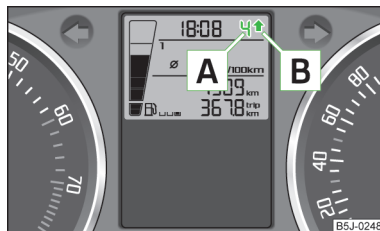

Fig. 21
Recommended gear

📖 Read and observe ! on page 30 first.

The gear currently engaged is shown in the instrument cluster display **[A]** » Fig. 21.

In order to minimise the fuel consumption, a recommendation for shifting into another gear is indicated in the display. ▶

¹⁾ On models on which the speedometer indicates mph, the second speed is displayed in km/h.

If the control unit recognises that it is beneficial to change gear, an arrow **B** is shown in the display. The arrow points up or down, depending on whether you should shift into a higher or lower gear.

At the same time, the **recommended** gear is shown at **A** instead of the gear **selected** on vehicles with a **manual gearbox**.

! CAUTION

The driver is always responsible for selecting the correct gear in different driving situations, such as overtaking.

Multifunction display (MFD)

📖 Introduction

This chapter contains information on the following subjects:

Memory	33
Operation	34
Multifunction display details	34
Warning against speeding	35

The multifunction display can only be operated when the ignition is switched on. After the ignition is switched on, the function displayed is the one which you last selected before switching off the ignition.

The multifunction display shown in the segment display » [Fig. 22 on page 33](#) or in the MAXI DOT display depending on your vehicle model » [page 37](#).

On vehicles with a MAXI DOT display » [page 37](#), there is an option not to display some of the information.

! WARNING

- Concentrate fully on your driving at all times. As the driver you are fully responsible for the operation of your vehicle.
- Even at temperatures of around +4 °C, there may still be black ice on the road surface. You should therefore not rely solely on the outside temperature display for accurate information as to whether there is ice on the road.

i Note

- In certain national versions the displays appear in the Imperial system of measures.
- If the display of the second speed is activated in mph, the current speed is not indicated in km/h on the display.

Memory

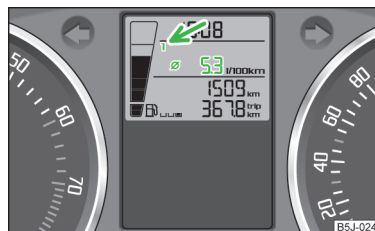

Fig. 22
Multifunction display

📖 Read and observe **!** on page 33 first.

The multifunction display is equipped with two automatic memories. The selected memory is shown in the Display » [Fig. 22](#).

The data of the single-trip memory (memory 1) is shown if a **1** appears in the display. A **2** shown in the display means that data relates to the total distance memory (memory 2).

Switch memories using button **B** » [Fig. 23 on page 34](#) on the windscreen wiper stalk.

Single-trip memory (memory 1)

The single-trip memory collates the driving information from the moment the ignition is switched on until it is switched off. New data will also flow into the calculation of the current driving information if the trip is continued **within 2 hours** after switching off the ignition. If the trip is interrupted for **more than 2 hours**, the memory is automatically erased.

Total-trip memory (memory 2)

The total trip memory collates the data from any number of individual trips up to a total of 19 hours and 59 minutes or 1999 km or, for vehicles with a MAXI DOT display, 99 hours and 59 minutes, or 9999 km. The memory is deleted when either of these limits is reached and the calculation starts all over again.

Unlike the single-trip memory, the total-trip memory is not deleted after a period of interruption of driving of 2 hours.

i Note

All information in the memory **1** and **2** is erased if the battery of the vehicle is disconnected.

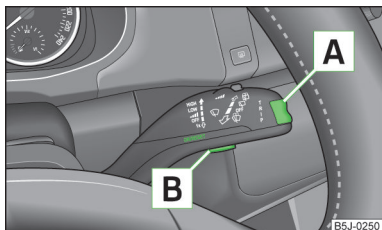

Fig. 23
Multifunction display: Control elements

Read and observe **I** on page 33 first.

The Toggle button for selecting menu items **A** » Fig. 23 and button **B** are found on the wiper stalk.

Select menu items

› Briefly press the top or bottom of rocker switch **A** » Fig. 23. This opens the individual menu items in the multifunction display one after the other.

Select memory

› Press button **B** » Fig. 23.

Reset memory

› Select the desired memory.

› Press and hold button **B** » Fig. 23.

The following values from the memory selected will be set to zero by button **B**.

- › Average fuel consumption.
- › Distance driven.
- › Average speed.
- › Driving time

¹⁾ This information is always shown on vehicles with a MAXI DOT display.

²⁾ This is not the case on the MAXI DOT display.

³⁾ On some models in certain countries, the display appears in kilometres/litre.

⁴⁾ On some models in certain countries, the display appears in --. - kilometres/litres if the vehicle is stationary.

Read and observe **I** on page 33 first.

Outside temperature

The current outside temperature is displayed¹⁾.

The temperature is shown with the snowflake symbol ❄ if the outside temperature is below +4 °C.

This display flashes for a few seconds, then shows the most recently displayed function²⁾.

If the temperature drops below +4 °C while the car is driving at a speed faster than 10 km / h, a beep is also heard.

Driving time

The driving time elapsed since the memory was last erased appears in the display. Reset the memory to zero by pressing the button » page 34, *Operation* to measure the driving time from a particular moment.

The maximum time indicated in both memories is 19 hours and 59 minutes and on vehicles which are fitted with a MAXI DOT display, it is 99 hours and 59 minutes. The indicator is set back to zero when this period is exceeded.

Current fuel consumption

The current fuel consumption level is displayed in litres/100 km³⁾. You can use this information to adapt your driving style to the desired fuel consumption.

The display appears in litres/hour if the vehicle is stationary or driving at a low speed⁴⁾.

Average fuel consumption

The average fuel consumption since the memory was last erased is displayed in litres/100 km³⁾.

Set the memory to zero at the start of a new measurement if you wish to determine the average fuel consumption over a certain period » page 34, *Operation*. No value will appear in the display after it has been erased until you have driven approximately 300 m.

The display is updated regularly while you are driving.

Range

The estimated range is displayed in kilometres. It indicates the distance you can still drive with your vehicle based on the level of fuel in the tank and the same style of driving.

The display is shown in steps of 10 km. The value is displayed in steps of 5 km after the  has come on.

The fuel consumption over the preceding 50 km is used to calculate the information. The range will increase if you drive in a more economical manner.

If the memory is set to zero (after the battery has been disconnected), a fuel consumption of 10 l/100 km is used initially, then the value is adapted according to the style of driving.

Distance travelled

The distance travelled since the memory was last erased is displayed. Reset the memory to zero if you want to measure the distance travelled from a particular moment » [page 34, Operation](#).

The maximum distance indicated in both memories is 1999 km or 9999 km on vehicles with a MAXI DOT display. The indicator is set back to zero when this period is exceeded.

Average speed

The average speed since the memory was last erased is displayed in km/hour. Set the memory to zero at the start of measurement to determine the average speed over a certain period » [page 34, Operation](#).

No value will appear in the display until you have driven approximately 300 m after this information has been deleted.

The display is updated regularly while you are driving.

Current speed

The current speed, identical to the display on the speedometer  » [Fig. 20 on page 30](#), is displayed.

Oil temperature¹⁾

The current engine oil temperature is displayed. If the oil temperature is lower than 50 °C or if a fault in the system for checking the oil temperature is present, only - -.- is displayed instead of the oil temperature.

¹⁾ Applies for vehicles using the MAXI DOT display.

²⁾ An initial value of 30 km/h is displayed automatically if no value has been specified.





Warning against speeding

The warning that the speed limit is being exceeded can be enabled/disabled in the display» [page 35](#).

Warning against speeding



 **Read and observe  on page 33 first.**

Adjust the speed limit while the vehicle is stationary

- Press button  » [Fig. 23 on page 34](#) to select the **Warning at** (MAXI DOT display) or  (segment display) menu item.
- Press button  to activate the ability to set the speed limit²⁾ (value flashes).
- Use button  to set the required speed limit, e.g. 50 km/h.
- Confirm the speed limit that was set with button , or wait approx. 5 seconds until the setting is saved automatically (the value stops flashing).

This allows you to set the speed in 5 km/h intervals.





Adjusting the speed limit while the vehicle is moving

- Press button  » [Fig. 23 on page 34](#) to select the **Warning at** (MAXI DOT display) or  (segment display) menu item.
- Drive at the desired speed, e.g. 50 km/h.
- Press button  to accept the current speed as the speed limit (the value flashes).

If you wish to adjust the set speed limit, you can do so in 5 km/h intervals (e.g. the accepted speed of 47 km/h increases to 50 km/h or decreases to 45 km/h).

- Confirm the speed limit that was set by pressing button  again, or wait approx. 5 seconds until the setting is saved automatically (the value stops flashing).

Change or delete speed limit

- Press button  » [Fig. 23 on page 34](#) to select the **Warning at** (MAXI DOT display) or  (segment display) menu item.
- Pressing button  disables the speed limit.
- Pressing the button  activates the ability to change the speed limit.

If the set speed limit is exceeded, an audible signal will sound as a warning. The **Warning at** (MAXI DOT display) or  (segment display) menu item appears in the display with the limit set. ▶

The speed limit set mode is stored even after the ignition is switched off and on.

Service Interval Display

Introduction

This chapter contains information on the following subjects:

Prompt in the segment display _____	36
Display in the MAXI DOT display _____	36
Resetting the service interval display _____	37

The service interval display shows the time and mileage to the next service event.

The service due date is automatically displayed on the display and this information can be displayed manually at any time if necessary.

The kilometre indicator or the days indicator reduces in steps of 100 km or days until the service due date is reached.

The information regarding the service intervals can be found in the service schedule.

i Note

Information is retained in the Service Interval Display even after the vehicle battery is disconnected.

Prompt in the segment display

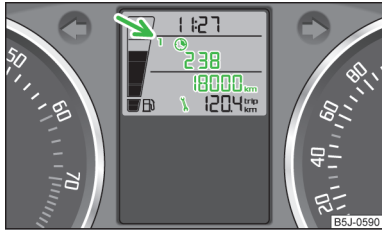





Fig. 24
Example of a message

Oil change service

If an **oil change service** is due, the  icon and the number **1** is displayed at the position identified with the arrow for approximately 10 seconds » Fig. 24.

The  icon is shown together with the days and kilometres remaining to the next service.

As soon as the service due date is reached, the flashing  icon and the message **OIL CHNG** appears in the display for about 20 seconds after the ignition is switched on.

Inspection



If an **inspection** is due, the  icon and the number **2** are displayed at the position identified with the arrow for approximately 10 seconds » Fig. 24.

The  icon is shown together with the days and kilometres remaining to the next service.

As soon as the due date for the service is reached, the flashing  icon and the **INSPEC _** message appear in the display for about 20 seconds after the ignition has been switched on.

Display the days and distance until the next service

You can press button **[5]** » Fig. 20 on page 30 repeatedly to display the remaining distance and time to until the next service whenever the ignition is switched on.

The  icon appears together with the  icon and the distance and time to the next service appear in the display for about 10 seconds.

The distance and the days remaining until the next **oil change service** are displayed first; the distance and the days remaining until the next **inspection** are displayed after the button **[5]** is pressed again.

i Note

The kilometres remaining until the next service are displayed instead of the odometer.

Display in the MAXI DOT display

Oil change service

If an **oil change service** is due, the message **Oil change in ... km or ... days**.

As soon as the service date has arrived, the message **Oil change now!** appears after the ignition is switched on.

Inspection

If an **inspection** is due, the message **Inspection in ... km or ... days**.

As soon as the service interval date has arrived, the message **Inspection now!** appears after the ignition is switched on. ▶

Displaying the distance and days until the next service interval

You can display the remaining distance and days until the next service in the **Settings** menu whenever the ignition is switched on » [page 38](#).

The following message is displayed for 10 seconds.

Oil change ... km / ... days

Inspection ... km / ... days

Resetting the service interval display

We recommend that the display reset is completed by a specialist garage.

We recommend that you do not reset the service interval display yourself. Incorrectly setting the service interval display could cause problems to the vehicle.

Variable service interval

For vehicles with variable service intervals, after resetting the oil change service display, the values of a new service interval are displayed, which are based on the previous operating conditions of the vehicle.

These values are then continuously matched according to the actual operating conditions of the vehicle.

MAXI DOT display

Introduction

This chapter contains information on the following subjects:

Main menu	37
Settings	38
Door, boot lid and bonnet warning	38
Auto Check Control	38

The MAXI DOT display provides you with information about the **current operating state of your vehicle**. The information system also provides you with data (depending on the vehicle equipment) relating to the radio, mobile phone, multi-functional display, navigation system, the device connected to the MDI input and the automatic gearbox » [page 110](#).

Lighting up of certain symbols is combined with an acoustic warning signal.

! WARNING

Concentrate fully on your driving at all times. As the driver you are fully responsible for the operation of your vehicle.

Main menu

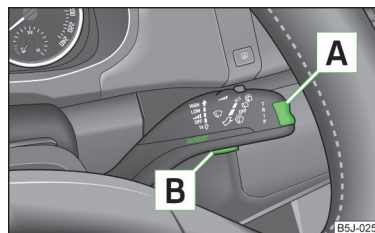

Fig. 25
Operating lever: MAXI DOT display controls

Read and observe ! on page 37 first.

- » Press and hold rocker switch **A** » [Fig. 25](#) to activate the **MAIN MENU**.
- » Individual menu items can be selected by pressing rocker switch **A**. When the pushbutton **B** is briefly pressed, the information you have selected is displayed.

Overview of the menu items in the main menu.

- **MFD** (Multifunction display) » [page 33](#)
- **Audio** » *Operating instructions for the radio*
- **Navigation** » *Operating instructions for the navigation system*
- **Phone** » [page 97](#);
- **Vehicle status** » [page 38](#)
- **Settings** » [page 38](#)

The **Audio** and **Navigation** menu items are only displayed when the factory-fitted radio or navigation system is switched on.

i Note

- Warning messages shown in the information display must be confirmed by pressing button **B** briefly » [Fig. 25](#) to call up the main menu.
- The menu always shifts to one of the higher levels after 10 seconds if the display is not currently active.
- Using the factory-fitted radio or navigation system » *Radio operating instructions* or » *Navigation system operating instructions*.

Settings

 Read and observe  on page 37 first.

You can change certain settings yourself through the MAXI DOT display. The current menu item is shown in the top of the display under a line.

You can select the following menu options:

Language

You can set the language for the warning and information texts here.

MFD data

Activate or deactivate certain displays of the multifunction display here.

Time

The time, time format (12 or 24 hour indicator) and the changeover between summer/winter time can be set here.

Winter tyres

Here, you can set the speed at which an audible signal should sound. This function is, for example, used for winter tyres where the maximum permissible speed is lower than the maximum speed of the vehicle.

The following is shown on the information display if this speed is exceeded:

Winter tyres: max. speed ... km/h.

Units of measurement

The units for the temperature, consumption and distance driven can be set here.

Alt. speed dis.

Display of the second speed in mph¹⁾ can be activated here.

Service

The days and kilometres remaining until the next service can be displayed here.

Factory setting

The display can be restored to its factory settings here.

Door, boot lid and bonnet warning

 Read and observe  on page 37 first.

If at least one door is open, or the boot or bonnet is open, the MAXI DOT display shows the vehicle with the corresponding door or boot/bonnet **open**.

An audible signal also sounds if the vehicle is travelling at more than 6 km/h.

Auto Check Control

 Read and observe  on page 37 first.

Vehicle condition



Certain functions and conditions of individual vehicle systems are checked continuously when the ignition is switched on and also while driving.

Some error messages and other information are displayed in the MAXI DOT display. The messages are displayed simultaneously with the icons in the MAXI DOT display or with the warning lights in the instrument cluster » page 39.

The **Vehicle status** menu item is shown in the main menu of the MAXI DOT display whenever at least one fault message is present. The first of the fault messages is displayed after this menu item is selected. Several error messages are shown on the display under the message e.g. **1/3**. This indicates that the first of a total of three error messages is being displayed.

As long as the operational faults are not rectified, the symbols are always indicated again. After they are displayed for the first time, the symbols continue to be indicated without any extra messages for the driver.

Warning symbols

	Engine oil pressure too low	» page 40
	Clutches of the automatic DSG gearbox are too hot	» page 38
	Check engine oil level, engine oil sensor defective	» page 40

Clutches of the automatic DSG gearbox are too hot

If the  symbol appears in the MAXI DOT display, this indicates that the temperature of the automatic DSG gearbox clutches is too high. ►

¹⁾ On models on which the speedometer indicates mph, the second speed is displayed in km/h.

The following message is shown in the MAXI DOT display.

M Gearbox overheated. Stop. Owner's manual!

Stop the vehicle, switch off the engine, and wait until the  icon goes out – there is a risk of gearbox damage. You can continue your journey as soon as the icon disappears.

! WARNING

If you have to stop for technical reasons, park the vehicle at a safe distance from the traffic, switch off the engine and switch on the hazard warning lights system » [page 63](#).















i Note













- Warning messages shown in the MAXI DOT display must be confirmed with button **[B]** » [Fig. 25 on page 37](#) to call up the main menu.
- As long as the operational faults are not rectified, the symbols are always indicated again. After they are displayed for the first time, the symbols continue to be indicated without any extra messages for the driver.

Warning lights

Introduction

This chapter contains information on the following subjects:

	Handbrake	39
	Brake system	40
	Seat belt warning light	40
	Generator	40
	Open door	40
	Engine oil	40
	Coolant	41
	Power steering	42
	Electronic Stability Control (ESC)	42
	Traction Control System (ASR)	42
	Anti-lock brake system (ABS)	42
	The rear fog light	43
	Bulb failure	43
	Exhaust inspection system	43
	Glow plug system (diesel engine)	43

	EPC fault light (petrol engine)	43
	Diesel particulate filter (diesel engine)	43
	Fuel reserve	44
	Airbag system	44
	Tyre pressure	45
	Windscreen washer fluid level	45
	Traction control (TCS) switched off	45
	Turning signal system	46
	Low beam	46
	Fog lights	46
	Cruise control system	46
	Selector lever lock	46
	Main beam	46

The warning lights show certain functions/faults and may be accompanied by audible signals.

! WARNING

- If illuminated warning lights and the corresponding descriptions and warning notes are not observed, this may result in severe injuries or major vehicle damage.
- The engine compartment of your car is a hazardous area. There is a risk of injuries, scalding, accidents and fire when working in the engine compartment, e.g. inspecting and replenishing oil and other fluids. It is essential to observe safety notes » [page 145, Engine compartment](#).

Handbrake

 **Read and observe  on page 39 first.**

The warning light  comes on if the handbrake is applied. An audible warning is also given if you drive the vehicle for at least 3 seconds at a speed of more than 6 km/h.

The following message is shown in the MAXI DOT display.

M Release parking brake!

Brake system

 Read and observe  on page 39 first.

The  indicator light comes on if the brake fluid level in the braking system is too low or there is a fault in the ABS.





The following message is shown in the MAXI DOT display.

 **Brake fluid: Owner's manual!**

Stop the vehicle, switch off the engine, and check the level of the brake fluid [» page 152](#).

Further information [» page 108, Brakes](#).

WARNING

- If you have to stop for technical reasons, then park the vehicle at a safe distance from the traffic, switch off the engine and activate the hazard warning light system [» page 63](#).
- The following guidelines should be observed when opening the bonnet and checking the brake fluid level [» page 145, Engine compartment](#).
- If the warning light  is displayed simultaneously with warning light  [» page 42](#),  *Anti-lock brake system (ABS)*,  **do not continue your journey!** Seek help from a specialist garage.
- A fault to the ABS system or the braking system can increase the vehicle's braking distance - there is a risk of accident.

Seat belt warning light

 Read and observe  on page 39 first.

The  indicator light comes on after the ignition is switched on as a reminder for the driver and front passenger to fasten their seat belt. The indicator light only goes out once the driver and front passenger have fastened their seat belt.

A steady warning signal sounds at vehicle speeds greater than 20 km/h and the  flashes if the driver and front passenger have not fastened their seat belts.

The warning signal is switched off and the  indicator light is permanently lit if the driver and front passenger have not fastened their seat belts within the next 90 seconds.

Further information [» page 12](#).

Generator

 Read and observe  on page 39 first.



If the warning light lights up  when the engine is running, the vehicle battery is not being charged.

Seek help from a specialist garage. The electrical system requires checking.

WARNING

If you have to stop for technical reasons, park the vehicle at a safe distance from the traffic, switch off the engine and switch on the hazard warning lights system [» page 63](#).

CAUTION

 **Do not continue driving** if the  warning light (coolant system fault) lights up in addition to the  warning light while you are driving. Stop the engine - there is a risk of engine damage.

Open door

 Read and observe  on page 39 first.

The warning light  comes on if one or several doors are opened or if the boot lid is opened.

The warning light comes on even when the ignition is switched off. The warning light lights up for a maximum of 5 minutes.

WARNING

If you have to stop for technical reasons, park the vehicle at a safe distance from the traffic, switch off the engine and switch on the hazard warning lights system [» page 63](#).

Engine oil

 Read and observe  on page 39 first.

The warning light  lights up red (low oil pressure). The following message is shown in the MAXI DOT display.

 **Oil pressure: Engine off. Owner's manual!**

The  warning light comes on for a few seconds when the ignition is switched on¹⁾.

Stop the vehicle, switch off the engine, and check the engine oil level » [page 149](#).

Even if the oil level is correct,  **do not drive any further** if the warning light is flashing. Also do not leave the engine running at an idling speed.

Seek help from a specialist garage.

The warning light lights up yellow (oil quantity too low)

The following message is shown in the MAXI DOT display.

Check oil level!

Stop the vehicle, switch off the engine, and check the engine oil level » [page 149](#).

An audible signal sounds as a warning signal.

The warning light will go out if the bonnet is left open for more than 30 seconds. If no engine oil has been replenished, the warning light will come on again after driving about 100 km.

The warning light flashes yellow (engine oil level sensor faulty)

The following message is shown in the MAXI DOT display.

Oil sensor workshop!

If the engine oil level sensor is faulty, the warning light flashes  several times and an audible signal sounds when the ignition is turned on.

Seek help from a specialist garage.

WARNING

If you have to stop for technical reasons, park the vehicle at a safe distance from the traffic, switch off the engine and switch on the hazard warning lights system » [page 63](#).

CAUTION

The red oil pressure light  is not an oil level indicator! One should therefore check the oil level at regular intervals, preferably after every refuelling stop.

¹⁾ The  warning light does not light up in vehicles fitted with the MAXI DOT display when the ignition is switched on, but only if there is a fault or the engine oil level is too low.

²⁾ Not on vehicles with the MAXI DOT display.

Coolant

 **Read and observe  on page 39 first.**

The  indicator light remains lit until the engine reaches operating temperature²⁾. Avoid high speeds, full throttle and high engine loads.

If the warning light  lights up or flashes, either the coolant temperature is too high or the coolant level is too low.

An audible signal sounds as a warning tone.

The following message is shown in the MAXI DOT display.

Check coolant! Owner's manual!

Stop the vehicle, switch off the engine, check the level of the coolant » [page 151](#), and refill the coolant if necessary » [page 151](#).

If the coolant is within the specified range, the increased temperature may be caused by an operating problem at the radiator fan. Check the fuse for the radiator fan, replace if necessary » [page 177](#), *Fuses in the engine compartment*.

Do not continue driving if the warning light   **does not go off even though the coolant level is correct and the fuse for the fan is in working order!**

Seek help from a specialist garage.

WARNING

- If you have to stop for technical reasons, then park the vehicle at a safe distance from the traffic, switch off the engine and activate the hazard warning light system » [page 63](#).
- Carefully open the coolant expansion bottle. If the engine is hot, the cooling system is pressurized - risk of scalding! It is therefore best to allow the engine to cool down before removing the cap.
- Do not touch the radiator fan. The radiator fan may switch itself on automatically even if the ignition is off - a danger of injury is present!

CAUTION

- Additional headlights and other attached components in front of the air inlet impair the cooling efficiency of the coolant.
- Never cover the radiator - there is a risk of the engine overheating.

Power steering



 Read and observe  on page 39 first.

The warning light  comes on for a few seconds when the ignition is switched on.

If the warning light after switching on the ignition or when driving lights up continuously, a fault exists in the electrohydraulic power steering. The power steering operates with reduced steering assist or does not function at all.

Seek help from a specialist garage.



Note

- If the yellow warning light  goes out after starting the engine again and driving a short distance, it is not necessary to visit a specialist garage.
- If the vehicle battery has been disconnected and reconnected, the yellow warning light  comes on after switching on the ignition. The warning light should go out after driving a short distance.
- There is no power-assisted steering support when the vehicle is being towed without the engine running or when the power-assisted steering is defect. The vehicle is fully steerable however. There is however increased force required to turn the steering wheel.

Electronic Stability Control (ESC)

 Read and observe  on page 39 first.

The warning light flashes  to show that the ESC is currently operating.



If the warning light  comes on immediately after you start the engine, the ESC might be switched off due to technical reasons. Switch the ignition off and on again. The ESC is fully functional again if the  warning light does not light up after you switch the engine back on.

There is a fault in the ESC system if the  warning light lights up.

The following message is shown in the MAXI DOT display.

Error: Electronic Stability Control (ESC)

Seek help from a specialist garage.

The ESC system cannot be turned off, the  » page 120 button only switches the TCS off, the  warning light in the instrument cluster lights up.

As the ESC operates in conjunction with the ABS, the ESP indicator light will also come on if the ABS system fails.

Further information » [page 119](#), *Electronic Stability Control (ESC)*.



Note

The  warning light comes on after the ignition is switched on if the vehicle's battery has been disconnected and reconnected. The warning light should go out after the vehicle has driven a short distance.

Traction Control System (ASR)

 Read and observe  on page 39 first.

The warning light flashes  to show that the ASR is currently operating.

If the warning light  comes on immediately after starting the engine, the ASR can be switched off for technical reasons. Switch the ignition off and on again. The TCS is fully functional again if the  warning light does not light up after you switch the engine back on.

If the warning light  lights up, there is a fault in the ASR.

The following message is shown in the MAXI DOT display.

Error: Traction control (ASR)

Seek help from a specialist garage.

The fact that the TCS system operates together with the ABS means that the TCS warning light will also come on if the ABS system is not operating properly.

Further information » [page 120](#), *Traction Control System (ASR)*.

Note

The  warning light comes on after the ignition is switched on if the vehicle's battery has been disconnected and reconnected. The warning light should go out after the vehicle has driven a short distance.

Anti-lock brake system (ABS)

 Read and observe  on page 39 first.

If the warning light  lights up, there is a fault in the ABS. ▶



The following message is shown in the MAXI DOT display.

Error: ABS

The vehicle will only be braked by the normal brake system without the ABS.

Seek help from a specialist garage.

WARNING

- If you have to stop for technical reasons, then park the vehicle at a safe distance from the traffic, switch off the engine and activate the hazard warning light system » [page 63](#).
- If the warning light  » [page 40](#) is displayed simultaneously with the ABS warning light , , **do not continue your journey!** Seek help from a specialist garage.
- A fault to the ABS system or the braking system can increase the vehicle's braking distance – there is a risk of accident.

The rear fog light

 **Read and observe  on page 39 first.**

The warning light  comes on when the rear fog lights are operating » [page 62](#).

Bulb failure

 **Read and observe  on page 39 first.**

The warning light  comes on if a bulb is faulty:
➤ within a few seconds of the ignition being switched on;
➤ when a light with a defective bulb is switched on.

The following message may be shown in the MAXI DOT display, for example.

 **INFORMATION Check front right low beam!**

Note

The rear side lights and the licence plate lighting have several light bulbs. The indicator light  only lights up if all light bulbs of the licence plate lighting or the parking light (in one rear light) are defective. For this reason, regular check that these light bulbs are working correctly.

Exhaust inspection system

 **Read and observe  on page 39 first.**

If the warning light  lights up, there is a fault in the exhaust inspection system. The engine control unit allows the vehicle to run in emergency mode.

Seek help from a specialist garage.

Glow plug system (diesel engine)

 **Read and observe  on page 39 first.**

The warning light  comes on after the ignition has been switched on. The engine can be started immediately after the pre-glow warning light goes out.

There is a fault in the glow plug system if the warning light  **does not** come on at all or **lights up continuously**.

If the warning light  begins to **flash** while driving, a fault exists in the engine control. The engine control unit allows the vehicle to run in emergency mode.

Seek help from a specialist garage.

EPC fault light (petrol engine)

 **Read and observe  on page 39 first.**

If the warning light  comes on or begins to flash while driving, a fault exists in the engine control unit. The engine control unit allows the vehicle to run in emergency mode.

Seek help from a specialist garage.

Diesel particulate filter (diesel engine)



 **Read and observe  on page 39 first.**

The diesel particulate filter separates the soot particles from the exhaust. The soot particles collect in the diesel particulate filter where they are burnt on a regular basis.

The  warning light comes on if soot has accumulated in the filter. ▶

In order to clean the filter, and where traffic conditions permit » , the vehicle should be driven at an even speed of at least 60 km/h at engine speeds of 1 800 - 2 500 rpm for at least 15 minutes or until the warning light goes out with the 4th or 5th gear engaged (automatic gearbox: position S) when the traffic situation permits it.

The  warning light only goes out once the diesel particulate filter has been successfully cleaned.

If the filter is not properly cleaned, the warning light  does not go out and the warning light  begins to flash.

The following message is shown in the MAXI DOT display.

 **Diesel particulate filter: Owner's manual!**

The engine control unit allows the vehicle to run in emergency mode. After switching the ignition off and on again the indicator light, the indicator light  also lights up.

Seek help from a specialist garage.

 **WARNING**

- The diesel particulate filter reaches very high temperatures - there is a fire hazard and serious injury could be caused. Therefore, never stop the vehicle at places where the underside of your vehicle can come into contact with flammable materials such as dry grass, undergrowth, leaves, spilled fuel or such like.
- Always adjust your speed to suit weather, road, region and traffic conditions. The recommendations indicated by the warning light must not tempt you to disregard the national regulations for road traffic.

 **CAUTION**

As long as the warning light  lights up, one must take into account an increased fuel consumption and in certain circumstances a power reduction of the engine.

 **Note**

- We recommend avoiding regularly driving short distances to assist the combustion process of the soot particles in the filter.
- Using diesel fuel with an increased sulphur content can considerably reduce the service life of the filter. A ŠKODA Service Partner will be able to tell you which countries use diesel fuel with a high sulphur content.
- If the engine is turned off during the filter cleaning process or shortly afterwards, the cooling fan may turn on automatically for a few minutes.

 **Fuel reserve**

 **Read and observe  on page 39 first.**

The indicator light  will come on if the fuel level is less than 7 litres.

An audible signal sounds as a warning signal.

The following message is shown in the MAXI DOT display.

 **Please refuel. Range: ... km**

 **Note**

The text in the MAXI DOT display only goes out after the vehicle has been refuelled and driven a short distance.

 **Airbag system**

 **Read and observe  on page 39 first.**

If the warning light  lights up, there is a fault in the airbag system.

The following message is shown in the MAXI DOT display.

 **Error: Airbag**

The operational capability of the airbag system is monitored electronically, even if one of the airbags is switched off.



If a front, side or head airbag or belt tensioner has been switched off using the vehicle system tester:

- ▶ The  warning light comes on for around 4 seconds after the ignition is switched on and then flashes for approximately another 12 seconds at 2 second intervals.

The following message is shown in the MAXI DOT display.

 **Airbag/belt tensioner deactivated.**

If the front passenger's front airbag was switched off using the key-operated switch on the side of the dash panel on the passenger side:

- The  warning light comes on for around 4 seconds after the ignition has been switched on.
- switching off the airbag is indicated in the middle of the dash panel by the lighting up of the yellow indicator light in display **PASSENGER AIR BAG OFF** , » page 21.

WARNING

When a fault in the airbag system occurs, there is a risk of the system not being triggered in the event of an accident. Therefore, this must be checked immediately by a specialized company.

Tyre pressure

 Read and observe  on page 39 first.

The indicator light  is lit

If while driving, the warning light  lights up, a tyre pressure change has occurred.

An audible signal sounds as a warning signal.

- Immediately reduce speed and avoid sudden steering and braking manoeuvres.
- Stop the vehicle, turn the ignition off and check the tyres and their inflation pressure » page 157.
- Correct the tyre pressure, if necessary or replace the wheel » page 166 or use the repair kit » page 169.
- Store the tyre pressure values in the system » page 125.

The indicator light  flashes for about 1 min. and remains lit

If the warning light  flashes for approximately 1 minute and stays on, there may be a fault in the tyre pressure monitoring system.

- Stop the vehicle, turn the ignition off and start the engine again.

If the warning light  flashes again after the engine has started, there is a system error.

Seek help from a specialist garage.

The following reasons can explain the warning light  being illuminated.

- The vehicle is loaded on one side. Distribute loads as evenly as possible.
- The wheels of one axle are loaded more heavily (e.g. when towing a trailer or when driving uphill or downhill).
- Snow chains are mounted.
- A wheel has been changed.

Store the tyre pressure values in the system » page 125.

CAUTION

Under certain circumstances (e.g. sporty style of driving, wintry or unpaved roads) the warning light  in the instrument cluster can be delayed or does not light up at all.

Note

If the battery has been disconnected, the warning light  illuminates after the ignition is switched on. The warning light should go out after driving a short distance.

Windscreen washer fluid level

 Read and observe  on page 39 first.

If the windscreen washer fluid level is too low, the warning light  comes on.

The following message is shown in the MAXI DOT display.

 Top up wash fluid!

Top up with liquid » page 147.

Traction control (TCS) switched off

 Read and observe  on page 39 first.



The ASR is switched off by pressing the button » page 120 and the warning light  illuminates.

The following message is shown in the MAXI DOT display.

 Traction control (ASR) deactivated.

Turning signal system

 Read and observe  on page 39 first.

Either the left  or right  warning light flashes depending on the position of the turn signal lever.

If a turn signal light fails, the warning light flashes at twice its normal rate.

Switching off the hazard warning light system is switched on will cause all of the turn signal lights as well as both warning lights to flash.

Further information » [page 61](#), *Turn signal and main beam lights*.

Low beam

 Read and observe  on page 39 first.

The warning light  comes on when low beam is selected » [page 59](#).

Fog lights

 Read and observe  on page 39 first.

The warning light  comes on when the fog lights are operating » [page 61](#).

Cruise control system

 Read and observe  on page 39 first.

The warning light  comes on when the cruise control is operating » [page 121](#).

Selector lever lock

 Read and observe  on page 39 first.

If the warning light  lights up, operate the brake pedal. This is necessary to be able to move the selector lever from position **P** or **N** » [page 111](#).

Main beam

 Read and observe  on page 39 first.

The warning light  comes on when the main beam or headlight flasher are selected » [page 61](#).

Unlocking and locking

Unlocking and locking

Introduction

This chapter contains information on the following subjects:

Vehicle key	47
Replacing the battery in the remote control key	47
Child safety lock	48
Opening/closing a door	48
Locking/unlocking the vehicle without central locking	49
Emergency locking of the doors	49

Vehicle key

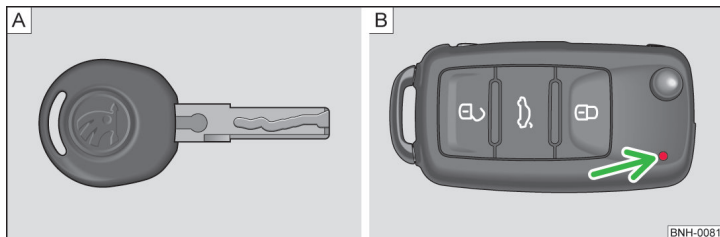

Fig. 26 Key: without/with remote control

Two keys are provided with the vehicle. Depending on the equipment, your vehicle can be equipped with keys without radio remote control » Fig. 26 - [A] or with radio remote control » Fig. 26 - [B].

! WARNING

- Never leave the key in the vehicle when you exit the vehicle. Unauthorized persons, such as children, for example, could lock the car, turn on the ignition or start the engine - there is a danger of injury and accidents!
- When leaving the vehicle, never leave persons who are not completely independent, such as children, unattended in the vehicle. The children might, for example, release the handbrake or take the vehicle out of gear. The ve-

! WARNING (Continued)

hicle could then start to move - risk of injury and accidents! These individuals might also not be able to leave the vehicle on their own or to help themselves. Can be fatal at very high or very low temperatures!

! CAUTION

- Each key contains electronic components; therefore it must be protected against moisture and severe shocks.
- Keep the groove of the keys absolutely clean. Impurities (textile fibres, dust, etc.) have a negative effect on the functionality of the locking cylinder and ignition lock.
- The operation of the remote control may temporarily be affected by interference from transmitters close to the car and which operate in the same frequency range (e.g. mobile phone, TV transmitter).
- The battery must be replaced if the central locking does react to the remote control at less than around 3 metres away » page 47.
- When leaving the vehicle, always check if it is locked.
- If the driver's door has been opened, the vehicle cannot be locked.

Replacing the battery in the remote control key

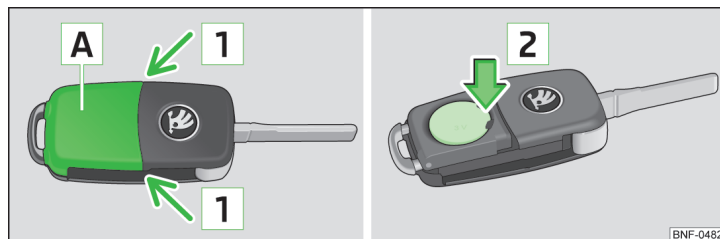

Fig. 27 Remote control key: Remove cover/remove battery

Each remote control key contains a battery located under the cover [A] » Fig. 27. The battery needs replacing if red indicator light » Fig. 26 on page 47 - [B] does not go on when you press a button on the remote control key. We recommend having the key batteries replaced by a specialist garage. However, if you would like to replace the discharged battery yourself proceed as follows.

- Flip out the key.

- Press off the battery cover with your thumb or using a flat screwdriver in the region of arrows **1** » Fig. 27.
- Remove the discharged battery from the key by pressing the battery downwards in the region of arrow **2**.
- Insert the new battery. Ensure that the "+" symbol on the battery is facing upwards. The correct polarity is shown on the battery cover.
- Place the battery cover on the key and press it down until it clicks into place.

! CAUTION

- Pay attention to the correct polarity when changing the battery.
- The replacement battery must have the same specification as the original battery.

♻️ For the sake of the environment

Dispose of the used battery in accordance with national legal provisions.

i Note

- The system has to be synchronised, if the vehicle cannot be unlocked or locked with the remote control key after replacing the battery » page 53.
- If a key has an affixed decorative cover, this will be destroyed when the battery is replaced. A replacement cover can be purchased from a ŠKODA Partner.

Child safety lock

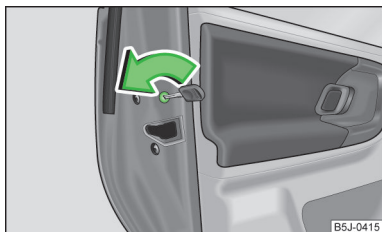

Fig. 28
Child safety lock: Left rear door

The child safety lock prevents the corresponding rear door from being opened from the inside. The door can only be opened from the outside.

You can switch the child safety lock on and off using the vehicle key.

Switching on

- Turn the slot of the safety lock in the direction of the arrow » Fig. 28 (the other way around on the right-hand door).

Switching off

- Turn the slot of the safety lock in the opposite direction to the arrow » Fig. 28 (the other way around on the right-hand door).

Opening/closing a door

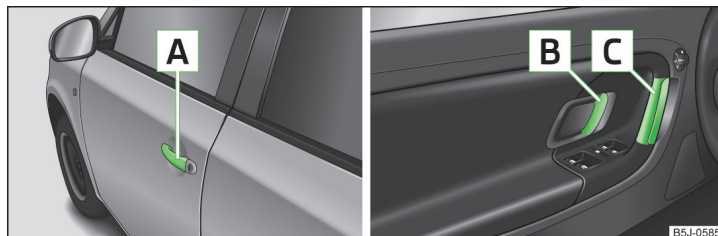

Fig. 29 Door handle/door opening lever:

Opening from the outside

- Unlock the vehicle and pull the door handle **A** » Fig. 29 on the door you wish to open.

Opening from the inside

- Pull on door opening lever **B** on the door you wish to open.

By the first pull on the opening lever, the door is **unlocked**.

By the second pull on the opening lever, the door is **opened**.

Closing from the inside

- Grasp pull handle **C** and close the door.

! WARNING

- Make sure that the door has closed correctly as it can open suddenly while the vehicle is being driven - there is a risk of death.
- Only open and close the door when there is no one in the opening/closing sweep - there is a risk of injury.
- An opened door can close spontaneously if there is a strong wind or the vehicle is on a slope - there is a risk of injury.
- Never drive with the doors open - there is a risk of death!

Locking/unlocking the vehicle without central locking

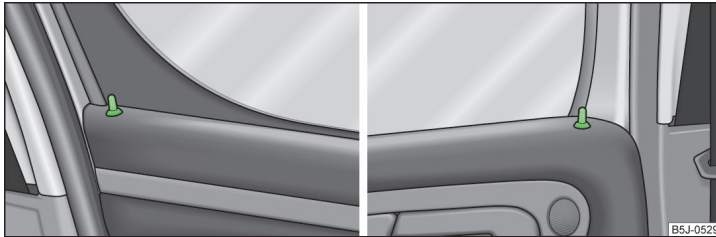

Fig. 30 Securing knob in the front door/rear door

The locking knob » Fig. 30 will move upwards or downwards when you lock or unlock the door.

Unlocking from the outside

› Unlock the front door with the key » page 51.

Unlocking from the inside

› Pull on the door opening lever.

Locking from the outside

› Lock the front door with the key » page 51.

Locking from the inside

› Push the locking knob » Fig. 30 down.

! WARNING

Locked doors prevent unwanted entry into the vehicle from outside, for example at road crossings. They do, however, make it more difficult for rescuers to get into the vehicle in an emergency - risk to life!

i Note

- Lock the opened rear doors and front passenger door by closing them and pressing the securing knob.
- It is not possible to lock the opened driver's door using the securing knob. This prevents against inadvertently locking the key in the vehicle.

Emergency locking of the doors

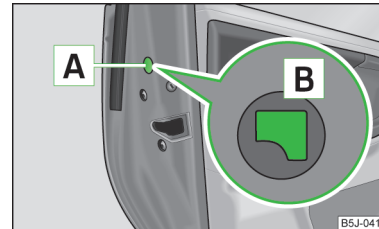

Fig. 31
Rear door: Emergency locking of the door

An emergency locking mechanism is located on the end face of the doors which have no locking cylinder, it is only visible after the door is opened.

Locking

› Remove the cover **A** » Fig. 31.

› Insert the key into the opening under the panel and press the stopping lever **B** as far as the stop toward the inside.

› Replace the cover.

After closing the door, it no longer be opened from the outside. The door can be unlocked from the inside by pulling on the door handle again, and then opened from the outside.

Central locking system

Introduction

This chapter contains information on the following subjects:

Individual settings	50
Safe securing	50
Unlocking the vehicle using the key	51
Locking the vehicle with the key	51
Vehicle locking/unlocking from the inside	51

When using central locking or unlocking, **all** doors are locked or unlocked simultaneously. The boot lid is unlocked when opening. It can be opened by pressing the handle above the licence plate » page 55, *Opening/closing*. ▶

Warning light in the driver's door

After locking the vehicle, the warning light flashes for around 2 seconds in quick succession, afterwards it begins to flash evenly at longer intervals.

If the vehicle is locked and the safe securing system » page 50 is not operating, the warning light in the driver door flashes for about 2 seconds fast, goes out and starts to flash evenly at longer intervals after about 30 seconds.

If the indicator light first flashes fast for about 2 seconds, then lights up for about 30 seconds continuously and then flashes slowly, there is a fault in the central locking system or in the interior monitor and in the towing protection » page 54. Seek help from a specialist garage.

Convenience operation of windows

The windows can be opened and closed when unlocking and locking the vehicle » page 57.

! CAUTION

If the safe securing system is activated » page 50, the door opening lever and the central locking buttons do not operate.

i Note

- In the event of an accident in which the airbags are deployed, the locked doors are automatically unlocked in order to enable rescuers to gain access to the vehicle.
- Upon failure of the central locking system, only the driver's door can be unlocked or locked using the key. The other doors and the tailgate can be manually locked or unlocked.
 - Emergency locking of the door » page 49.
 - Emergency unlocking of the boot lid » page 55.

Individual settings

📖 Read and observe ! on page 50 first.

Opening a single door

This selection function makes it possible to only unlock the driver's door. The other doors remain locked and are only unlocked when the command is repeated.

Automatic locking and unlocking

All the doors and the boot lid are locked automatically once the car reaches a speed of about 15 km/h.

If the ignition key is withdrawn, the car is then automatically unlocked again. In addition, it is possible for the driver or front passenger to unlock the car by pressing the central locking button 🔑 » page 51.

The doors can be unlocked and opened from the inside by pulling on the opening lever of the respective door. By the first pull on the opening lever, the door is **unlocked**. By the second pull on the opening lever, the door is **opened**.

i Note

Individual settings can be applied in a specialist workshop.

Safe securing

📖 Read and observe ! on page 50 first.

The central locking system is equipped with a **safe securing system**. The door locks are blocked automatically if the vehicle is locked from the outside. It is then not possible to open the doors with the door handle, either from the inside or from the outside.

You will be informed that the safe lock system is activated after the vehicle is locked by the **CHECK SAFE LOCK** message on the instrument cluster display. On vehicles equipped with the MAXI DOT display, the display shows **Check deadlock. Owner's manual!**

Switching off

The safe lock can be switched off in one of the following ways.

- By locking twice within 2 seconds.
- By disabling the interior monitoring » page 54, *Interior monitor and towing protection*.

If the vehicle is locked and the safe lock system is switched off, the door can be unlocked and opened from the inside by pulling on the opening lever of the respective door. By the first pull on the opening lever, the door is **unlocked**. By the second pull on the opening lever, the door is **opened**.

Switching on

The safe lock switches on automatically the next time the vehicle is locked and unlocked.

Switch-on display

The warning light flashes for around 2 seconds in quick succession, afterwards it begins to flash evenly at longer intervals. ▶

Switch-off display

The indicator light in the driver door flashes fast for about 2 seconds, goes out and starts to flash regularly at longer intervals after about 30 seconds.

! WARNING

If the car is locked from the outside and the safe lock system is switched on, no-one must be in the car, as it is then not possible to open either a door or a window from the inside. The locked doors make it more difficult for rescuers to get into the vehicle in an emergency – risk to life.

i Note

This function is only enabled in certain countries.

Unlocking the vehicle using the key

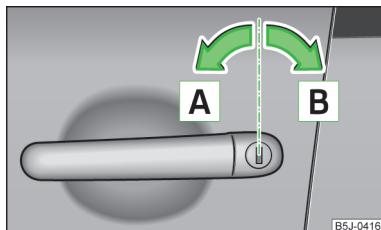

Fig. 32
Driver's door: Turning the key for
unlocking and locking the vehicle

! Read and observe **!** on page 50 first.

- Turn the key in the locking cylinder of the driver's door in the direction of travel (unlocking position) **A** » Fig. 32.
- Pull the door handle and open the door.
- All the doors (only the driver's door on vehicles with anti-theft alarm system) are unlocked.
- The boot lid is then unlocked.
- The switched on interior lights come on over the door contact.
- The safe securing system is deactivated.
- The windows open while the key is held in the unlock position.
- The warning light in the driver door stops flashing if the car is not fitted with an anti-theft alarm system » page 53.

Locking the vehicle with the key

! Read and observe **!** on page 50 first.

- Turn the key in the locking cylinder of the driver's door opposite to the direction of travel (locking position) **B** » Fig. 32 on page 51.
- All the doors and the boot lid are locked.
- The switched on interior lights will switch off over the door contact.
- The windows close while the key is held in the lock position.
- The safe securing system is immediately activated.
- The warning light in the driver door begins flashing.

i Note

If the driver's door has been opened, the vehicle cannot be locked.

Vehicle locking/unlocking from the inside



Fig. 33
Centre console: Central locking
button



! Read and observe **!** on page 50 first.

If the vehicle was not locked from the outside, you can also unlock and lock it with the rocker switch » Fig. 33 even if the ignition is not switched on.

Locking all doors and the boot lid

➤ Press  on the button » Fig. 33. The symbol  in the button comes on.

Unlocking all doors and the boot lid

➤ Press  on the button » Fig. 33. The symbol  in the button is no longer illuminated.

The following applies if your vehicle has been locked using the central locking button.

- It is not possible to open the doors or the boot lid from the outside (safety feature, e.g. when stopping at traffic lights etc.).
- The doors can be unlocked and opened from the inside by pulling on the opening lever of the respective door. By the first pull on the opening lever, the door is **unlocked**. By the second pull on the opening lever, the door is **opened**.
- If at least one door has been opened, the vehicle cannot be locked.
- In the event of an accident in which the airbags are deployed, the locked doors are automatically unlocked in order to enable rescuers to gain access to the vehicle.

! WARNING

- Doors locked from the inside make it difficult for rescuers to get into the vehicle in an emergency – risk to life!
- If the safe lock system is switched on » [page 50](#), the door opening lever and the central locking buttons do not operate.

Remote control

Introduction

This chapter contains information on the following subjects:

Unlocking/locking _____	52
Synchronization _____	53

You can use the remote control key to:

- unlock and lock the vehicle,
- unlocking boot lid;
- open and close the windows » [page 57](#), *Window convenience operation*.

The transmitter with the battery is housed in the handle of the remote control key. The receiver is located in the interior of the vehicle. The operating range of the remote control key is approx. 30 m. But this range of the remote control can be reduced if the batteries are weak.

The key has a fold-open key bit which can be used for unlocking and locking the car manually and also for starting the engine.

If a lost key is replaced or if the receiver unit has been repaired or replaced, the system must be initialised by a specialist garage. Only then can the remote control key be used again.

i Note

- The remote control is automatically deactivated when the ignition is switched on.
- The operation of the remote control may temporarily be affected by interference from transmitters close to the car and which operate in the same frequency range (e.g. mobile phone, TV transmitter).
- The battery must be replaced if the central locking or anti-theft alarm system does react to the remote control at less than 3 metres away » [page 47](#).

Unlocking/locking

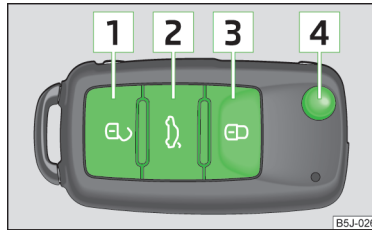

Fig. 34
Remote control key

Unlocking the vehicle

- Press button **1** » [Fig. 34](#).

Locking the vehicle

- Press button **3** » [Fig. 34](#).

Deactivating the safe securing system

- Press button **3** » [Fig. 34](#) twice within 2 seconds. Further information » [page 49](#).

Unlocking the boot lid

- Press button **2** » [Fig. 34](#). Further information » [page 55](#).

Folding out the key bit

- Press button **4** » [Fig. 34](#).

Folding in the key bit

- Press the button **4** » [Fig. 34](#) and fold in the key bit.

Unlocking

The turn signal lights flash twice as confirmation that the vehicle has been unlocked. If the vehicle is unlocked using button **1** » [Fig. 34](#) and none of the doors or the tailgate are opened within the next 30 seconds, the vehicle is

automatically locked again and the safe securing system or anti-theft alarm system is reactivated. This function is intended to prevent the car being unlocked unintentionally.

In addition, when the car is unlocked, the electrically adjustable seats and exterior mirrors move into the position assigned to this key. The stored setting of driver seat and exterior mirrors is retrieved.

Locking

The turn signal lights flash once to confirm that the vehicle has been correctly locked.

If the doors or the boot lid remain open after the vehicle has been locked, the turn signal lights do not flash until they have been closed.

Note

- Only operate the remote control when the doors and boot lid are closed and the vehicle is in your line of sight.
- A ŠKODA partner can also activate/deactivate the acoustic signals on vehicles with an anti-theft alarm system.

Synchronization

If the vehicle does not unlock when the remote control is pressed, the key may not be synchronised. This can occur when the buttons on the remote control key are pressed several times outside the operating range of the equipment or if the battery in the remote control key has been replaced.

Synchronise the key as follows.

- Press any button on the remote control key.
- Unlock the door with the key within 1 minute of pressing the button.

Anti-theft alarm system

Introduction

This chapter contains information on the following subjects:

Operation	53
Interior monitor and towing protection	54

The anti-theft alarm system increases the level of protection against people trying to break into the vehicle.

The alarm system triggers audible and visual signals if an attempt is made to break into the vehicle (hereafter referred to only as alarm).

Note

- The working life of the alarm siren is 5 years.
- Before leaving the vehicle, check that all the doors and windows are closed in order to ensure that the anti-theft alarm system is fully operational.
- Coding of the radio remote control and the receiver unit precludes the use of the radio remote control from other vehicles.

Operation

How is the alarm system activated?

The anti-theft alarm system is activated when the vehicle is locked with the radio remote control or the key in the driver's door. It is activated 30 seconds after locking the door.

How is the alarm system deactivated?

The alarm system is deactivated by pressing the  button on the remote control. The anti-theft alarm system is reactivated if the vehicle is not opened within 30 seconds after transmitting the radio signal.

Triggering the alarm

The alarm is triggered when the following unauthorized actions are carried out on the locked vehicle.

- Opening the bonnet.
- Opening the boot lid.
- Opening the doors.
- Manipulation of the ignition lock.
- Towing the vehicle » [page 54](#).
- Movement in the vehicle » [page 54](#).
- Sudden and significant voltage drop of the electrical system.
- Uncoupling the trailer » [page 129](#).

If the driver's door of a vehicle with a remote control is unlocked and opened by the lock cylinder, then the alarm is triggered.

Switching off the alarm

The alarm is turned off by pressing the  button on the radio remote control key or switching on the ignition. ▶

! CAUTION

Before leaving the vehicle, check that the doors and windows are closed in order to ensure that the alarm system is fully operational.

Interior monitor and towing protection

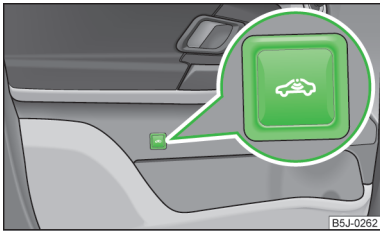



Fig. 35
Button for interior monitor and towing protection

The interior monitor detects movements inside the car and then triggers the alarm.

Switching off

- > Switch off the ignition.
- > Open the driver door.
- > Press the  » Fig. 35 button in the driver's door.
- > Lock the vehicle within 30 seconds.

The interior monitor and the towing protection are switched on again automatically the next time the car is locked.

i Note

- Deactivate the interior monitor and the towing protection if there is a possibility of the alarm being triggered by movements (e.g. by children or animals) within the vehicle interior or if the vehicle has to be transported (e.g. by train or ship) or towed.
- The opened glasses storage compartment reduces the effectiveness of the interior monitor. To ensure the full functionality of the interior monitor, the glasses storage compartment must always be closed before locking the vehicle.

Luggage compartment lid

Introduction

This chapter contains information on the following subjects:

Opening/closing _____	55
Delayed locking of the boot lid _____	55
Emergency unlocking _____	55

! WARNING

- Ensure that the lock is properly engaged after closing the boot lid. Otherwise, the lid might open suddenly while the vehicle is moving, even if the lid was locked - risk of accident!
- Never drive with the luggage compartment lid open or ajar, as otherwise exhaust gases may get into the interior of the vehicle - risk of poisoning!
- Do not press on the rear window when closing the tailgate, as otherwise this could crack - there is a risk of injury.
- Make sure that when closing the boot lid, no body parts are crushed - there is danger of injury!

i Note

- **After closing the boot lid, it is automatically locked within 1 second and the anti-theft alarm system is activated.** This applies only if the vehicle was locked before closing the boot lid.
- The function of the handle above the licence plate is deactivated when starting off or at a speed of 5 km/hour or more for vehicles with central locking. The function of the handle is activated again when the vehicle has stopped and a door is opened.

Opening/closing

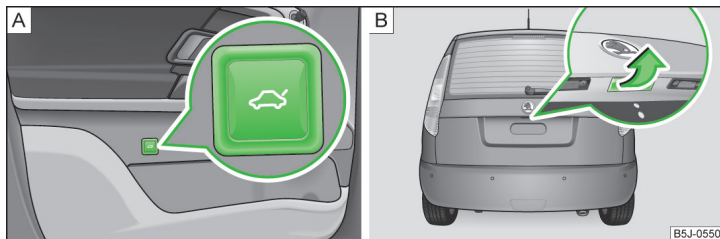

Fig. 36 Unlock the boot lid/boot lid handle

Read and observe **!** on page 54 first.

After unlocking the vehicle, you can open the lid by pushing the handle located above the licence plate.

Opening the boot lid for vehicles without central locking

➤ Press the button » Fig. 36 - [A] in the driver's door and open the boot lid in the direction of arrow » Fig. 36 - [B].

Opening the boot lid for vehicles with central locking

➤ Press the handle and open the tailgate in the direction of the arrow » Fig. 36 - [B].

Closing

➤ Pull down the tailgate and close it with a gentle swing.

A handle which makes the closing easier is located on the inner panelling of the boot lid.

Delayed locking of the boot lid

Read and observe **!** on page 54 first.

If the boot lid is unlocked with the symbol button on the remote control key, then the door is automatically locked after closing.

The period after which the boot lid is locked automatically can be extended by a specialist garage.

After activation of delayed locking, the boot lid can be opened again after closing within a limited period.

Delayed locking can be deactivated by a specialist garage at any time.

! CAUTION

There is a risk of unwanted entry into the vehicle before the boot lid is locked automatically. We therefore recommend locking the vehicle with the symbol button on the remote control key.

Emergency unlocking

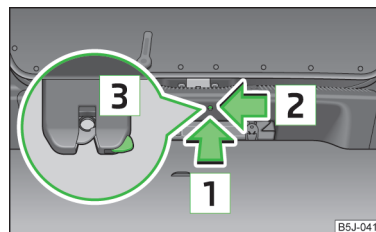

Fig. 37
Emergency unlocking of the boot lid

Read and observe **!** on page 54 first.

The boot lid can be unlocked manually if there is a fault in the central locking system.

Unlocking

- Fold the rear seat backrest forward » page 70.
- Insert a screwdriver or similar tool into the opening in the trim in the direction of the arrow [1] » Fig. 37 as far as the stop.
- Unlock the lock [3] under the trim in the direction of arrow [2].
- Open the tailgate.

Electrical power windows

Introduction

This chapter contains information on the following subjects:

Opening/closing the windows	56
Power window force limiter	57
Window convenience operation	57
Operational faults	57 ▶

! WARNING

- If the vehicle is locked from the outside, do not leave anybody in the vehicle as it is not possible to open the windows from the inside in the event of an emergency.
- The system is fitted with a force limiter » page 57. If there is an obstacle, the closing process is stopped and the window goes down by several centimetres. The windows should nevertheless be closed carefully - risk of injury.
- Deactivating the electrically operated power windows in the rear doors is recommended (safety push button) [S] when children are being transported in the rear seats » Fig. 38 on page 56.
- When closing the windows, proceed with caution so as to avoid causing crushing injuries - risk of injury!

! CAUTION

- Keep the windows clean to ensure the correct functionality of the electric windows.
- If the windows are frozen, first of all remove the ice » page 138, *Windows and exterior mirrors*. Only then can the electrical power windows be operated, as otherwise the window seal and the electrical power window mechanism could be damaged.
- In the winter, ice on the window may cause greater resistance as the window is closed. The window will stop and open again by several centimetres.
- Make sure that the windows are closed whenever you leave the locked vehicle.

🌿 For the sake of the environment

At high speeds, you should keep the windows closed to prevent unnecessarily high fuel consumption.

i Note

- After switching the ignition off, it is still possible to open or close the windows for approx. 10 minutes. After the driver's or front passenger's door has been opened, the windows can only be operated by using button [A] » Fig. 38 on page 56.
- When driving always use the existing heating, air conditioning and ventilation system for ventilating the interior of the vehicle. If the windows are opened, dust as well as other dirt can get into the vehicle and in addition the wind noise is more at certain speeds.

Opening/closing the windows

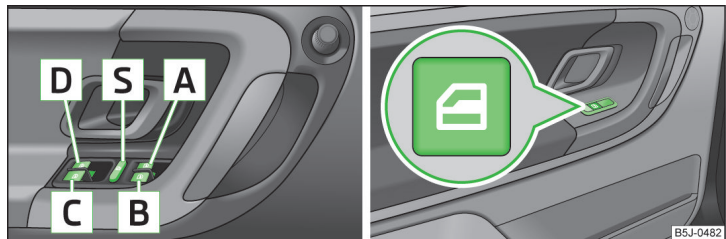

Fig. 38 Buttons on the driver's door/in the rear doors

📖 Read and observe ! and ! on page 56 first.

Power window buttons » Fig. 38

- [A] Button for electrical power window of the driver's door
- [B] Button for electrical power window of the front passenger door
- [C] Button for electrical power window of the rear right door
- [D] Button for electrical power window of the rear left door
- [S] Safety pushbutton

The electrical power windows can only be operated when the ignition is switched on.

Opening

▶ The window is opened by pressing lightly on the corresponding button. The opening process stops when one releases the button.



The window will also open fully automatically if you briefly press the button as far as the stop. Renewed pressing of the button causes the window to stop immediately.



Closing

▶ The window is closed by pulling lightly on the corresponding upper edge of the button. The closing process stops when one releases the button.

The window will also close fully automatically if you briefly pull the button as far as the stop. Renewed pulling of the button causes the window to stop immediately. ▶

Safety pushbutton

The buttons for power windows in the rear doors can be deactivated by pressing the safety switch  » Fig. 38. The buttons for the electrical power windows in rear doors are activated again by pressing the safety pushbutton  again.

If the buttons for the rear doors are deactivated, the warning light  in the safety switch  lights up.

Note

The window lift mechanism is equipped with protection against overheating. Repeated opening and closing of the window can cause this mechanism to overheat. If this happens, it will not be possible to operate the window for a short time. You will be able to operate the window again as soon as the overheating protection has cooled down.

Power window force limiter

 Read and observe  and  on page 56 first.

The electrical power windows are fitted with a force limiter. It reduces the risk of bruises or injuries when closing the windows.

If there is an obstacle, the closing process is stopped and the window goes down by several centimetres.

If the obstacle prevents the window from being closed during the next 10 seconds, the closing process is interrupted once again and the window goes down by several centimetres.

If you attempt to close the window again within 10 seconds of the window being moved down for the second time, even though the obstacle was not yet removed, the closing process is only stopped. During this time it is not possible to automatically close the window. The force limiter is still switched on.

The force limiter is only switched off if you attempt to close the window again within the next 10 seconds - **the window will now close with full force!**

If you wait longer than 10 seconds, the force limiter is switched on again.



Window convenience operation

 Read and observe  and  on page 56 first.



The convenience operation of the windows offers the possibility of opening or closing all the windows at once.

Convenience operation can take place in one of the following ways.

Opening

- Press the  symbol button on the remote control key and hold.
- Hold the key in unlock position in the driver's door lock.
- Hold button  » Fig. 38 on page 56 in the opening position.

Closing

- Press the  symbol button on the remote control key and hold.
- Hold the key in the lock position in the driver's door lock.
- Hold button  » Fig. 38 on page 56 in the closing position.

The movement of the window is stopped immediately when the key or the respective button is released.

Operational faults

 Read and observe  and  on page 56 first.

Electrical power windows do not operate

If the battery has been disconnected and then reconnected while the window was opened, the electrical power windows will not operate. The system must be activated. Proceed as follows to re-establish the function.

- Switch on the ignition.
- Pull the top edge of the button in the driver's door and close the window.
- Release the button.
- Pull the relevant button upwards again for another approximately 3 seconds and hold.

Operation in winter

In the winter, ice accumulating on the surface of the window may cause there to be more resistance when closing the window. The window will stop and move back several centimetres.

It is necessary to deactivate the force limiter to close the window » page 57.

Mechanical windows

Introduction

This chapter contains information on the following subjects:

Open / close window _____ 58

The window can be operated mechanically by means of the handle attached to the respective door panel.

! WARNING

The windows should nevertheless be closed carefully - risk of injury!

! CAUTION

- In the event that the windows are frozen, first of all eliminate the ice » [page 138, Windows and exterior mirrors](#) and only then operate the electrical power windows. Otherwise, the window sealing and the electrical power window mechanism could be damaged.
- Always make sure that the windows are closed when you leave the locked vehicle.

🌿 For the sake of the environment

At high speeds, you should keep the windows closed to prevent unnecessarily high fuel consumption.

i Note

When driving always use the existing heating, air conditioning and ventilation system for ventilating the interior of the vehicle. If the windows are opened, dust as well as other dirt can get into the vehicle and in addition the wind noise is more at certain speeds.

Open / close window

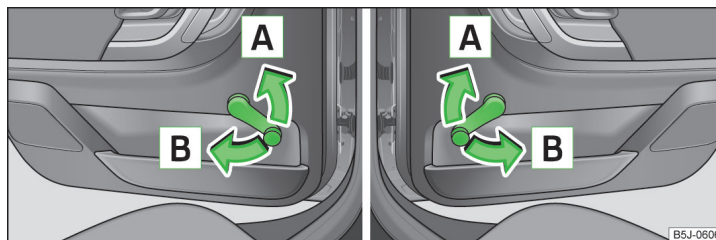

Fig. 39 Window operation: left / right

📖 Read and observe ! and ! on page 58 first.

Only one window can be operated mechanically at any time.

Opening

Lift the crank in the direction of arrow **A** » Fig. 39.

Closing

Turn the crank in the direction of the arrow **B** » Fig. 39.

Lights and visibility

Lights

Introduction

This chapter contains information on the following subjects:

Switching the light on/off	59
Headlight beam adjustment	60
Daylight running lights (DAY LIGHT)	60
Turn signal and main beam lights	61
Halogen projector headlights with cornering light function	61
Fog lights	61
Foglights with the CORNER function	62
Rear fog light	62
Tourist lights	62
Hazard warning light system	63
Parking lights	63

Unless otherwise stated, the lights only work when the ignition is on.

The layout of the controls differs in part from that shown in » Fig. 40 on page 59 on **right-hand drive** vehicles. The symbols which mark the positions of the controls are identical.

! WARNING

- Never drive with only the side lights on! The side lights are not bright enough to light up the road sufficiently in front of you or to be seen by other oncoming traffic. Therefore always switch on the low beam when it is dark or if visibility is poor.
- The activation of the lights should only be undertaken in accordance with national legal requirements.
- The driver is always responsible for the correct settings and use of the lights.

i Note

The headlights may mist up temporarily. When the driving lights are switched on, the light outlet areas are free from condensation after a short time, although the headlight lenses may still be misted up around the edge. This mist has no influence on the life of the lighting system.

Switching the light on/off



Fig. 40
Dash panel: Light switch

Read and observe ! on page 59 first.

Light switch positions » Fig. 40.

- ☛ Switch on the parking light or parking lights on both sides » page 63
- ☛ Switch on low beam
- 0 Switching off lights (except daytime running lights)
- ☛ Switch on the front fog lamp » page 61
- ☛ Switching on the rear fog light » page 62

i Note

- An audible warning signal will sound if the light switch is in the ☛ or ☛ position, the ignition key is removed and the driver's door is opened. The audible warning signal is switched off by means of the door contact when the driver's door is closed (ignition off), however, the side lights remain on to illuminate the parked vehicle if necessary.
- **Always turn the light switch to the 0 position if you are leaving the vehicle and don't want to use the parking light.**

Headlight beam adjustment



Fig. 41
Dash panel: Lights and visibility

Read and observe **!** on page 59 first.

Turning the rotary switch **»** Fig. 41 from position **—** to **3** gradually adjusts the headlight beam thereby shortening the beam of light.

The positions of the rotary switch correspond approximately to the following car load.

- Front seats occupied, boot empty.
- 1** All seats occupied, boot empty.
- 2** All seats occupied, boot loaded.
- 3** Driver seat occupied, boot loaded.

! WARNING

- Always adjust the headlight beam to satisfy the following conditions.
- The vehicle does not dazzle other road users, especially oncoming vehicles.
 - The beam range is sufficient for safe driving.

i Note

We recommend you adjust the headlight beam when the low beam is switched on.

Daylight running lights (DAY LIGHT)

Read and observe **!** on page 59 first.

Switching on daytime running lights

» Turn the light switch to position **0** **»** Fig. 40 on page 59.

Activating/deactivating the daytime running lights function

» Activate and deactivate the daytime running lights by fitting/removing the fuse with the appropriate ampere rating for daytime running lights **»** page 176, *Fuses in the dash panel*.

Deactivating on vehicles with the START-STOP system

- »** Switch off the ignition.
- »** At the same time, pull the turn signal light stalk **»** Fig. 42 on page 61 towards the steering wheel, push it downwards, and hold it in this position.
- »** Switch on the ignition - wait until the left-turn signal light flashes 4x.
- »** Switch off the ignition - an audible signal sounds which confirms the deactivation of the daylight driving lights.
- »** Release the turn signal stalk.

Activating on vehicles with the START-STOP system

- »** Switch off the ignition.
- »** At the same time, pull the turn signal light stalk **»** Fig. 42 on page 61 towards the steering wheel, push it upwards, and hold it in this position.
- »** Switch on the ignition - wait until the right-turn signal light flashes 4x.
- »** Switch off the ignition - an audible signal sounds which confirms the activation of the daylight driving lights.
- »** Release the turn signal stalk.

On vehicles with separate lights for daylight driving lights in the fog lights or in the front bumper, the parking lights and the licence plate light do not come on when activating the function daylight driving lights (neither front nor rear).

If the vehicle is not equipped with separate lights for daylight driving lights, the combination of the low beam, the parking lights (front and rear) including the licence plate light is used as daylight driving lights.

i Note

The daytime driving lights also serve as parking lights on vehicles with separate lights for daylight driving lights (in the bumper below the main headlights).

Turn signal and main beam lights

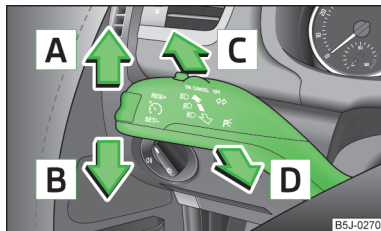

Fig. 42
Operating lever: Turn signal and
main beam operation

Read and observe **!** on page 59 first.

The parking light is controlled with the control stalk » page 63.

Control stalk positions » Fig. 42.

- A** Switch on right turn signal ⇨
- B** Switch on left turn signal ⇦
- C** Switch on high beam (spring-loaded position) ⚡
- D** Switch off main beam and headlamp flasher (spring-loaded position) ⚡

When the left or right turn signal is on, the ⇦ or ⇨ warning light flashes in the instrument cluster.

When the high beam or headlight flasher is on, the ⚡ warning light lights up in the instrument cluster.

Turn signal for changing lanes - to flash only briefly, move **the stalk** up or down to the pressure point only and **hold it in this position**.

Convenience turn signal

If you wish to flash three times only, briefly push **the stalk** to the upper or lower pressure point and **release again**.

! WARNING

Only turn on the main beam or the headlight flasher if other road users will not be dazzled.

i Note

- The **main beam** can only be switched on when the low beam lights are on.
- The **headlight flasher** can be operated even if the ignition is switched off.
- The **turn signal system** only operates when the ignition is switched on.

- The turn signal is automatically cancelled after negotiating a curve.
- The warning light flashes at twice its normal rate if a bulb for the turn signal light fails.

Halogen projector headlights with cornering light function

Read and observe **!** on page 59 first.

For a better cornering illumination, the halogen projector headlights with cornering light function are set in the optimal position in line with the vehicle speed and the steering angle.

! WARNING

If the halogen projector headlights with cornering light function are faulty, the headlights are automatically lowered to the emergency position, which prevents a possible dazzling of oncoming traffic. Thus the illuminated length of the road is shortened. Drive carefully and visit a specialist garage as soon as possible.

Fog lights

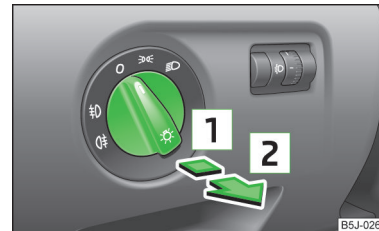

Fig. 43
Dash panel: Light switch

Read and observe **!** on page 59 first.

Switching on/off

- First turn the light switch » Fig. 43 to position ⚡ or ⚡.
- Pull the light switch to position **1**.

The rear fog light is switched off in the reverse sequence.

The warning light ⚡ lights up in the instrument cluster when the fog lights are switched on » page 39.

Foglights with the CORNER function

 Read and observe  on page 59 first.

The CORNER function lights the front fog lamp on the relevant side of the vehicle to illuminate the area around the vehicle when turning, parking, etc.

The CORNER function is switched on automatically if the following conditions are met.

- The turn signal is switched on or the front wheels are turned sharply to the right or left¹⁾.
- The engine is running.
- The vehicle is stopped or moves at a speed of no more than 40 km/h.
- The low beam is switched on.
- The daytime running lights are not switched on.
- The fog lights are not switched on.
- Reverse gear is not engaged.

Rear fog light

 Read and observe  on page 59 first.

Switching on/off

- First turn the light switch » Fig. 43 on page 61 to position  or .
- Pull the light switch to position .

The rear fog light is switched off in the reverse sequence.

If the vehicle is not fitted with fog lights, the rear fog light is switched on by pulling out the light switch directly to the only possible setting.

The warning light  lights up in the instrument cluster when the rear fog light is switched on » page 39.

Only the rear fog light on the trailer lights up if the vehicle has a factory-fitted towing device or a towing device from ŠKODA original accessories and it is driven with a trailer.

¹⁾ If both switch on versions are conflicting, for example if the steering wheel is turned to the left and the right turn signal light is switched on, the turn signal light has the higher priority.

Tourist lights

 Read and observe  on page 59 first.

Halogen projector headlights with cornering light function

This mode makes it possible to drive in countries with opposing traffic system (driving on the left/right) without dazzling the oncoming vehicles. When the mode "tourist light" is active, the side to side swivel of the headlights is deactivated.

Activating tourist light

Before activating the tourist light, the following conditions must be met.

Ignition switched off, light switched off (light switch in position **O**), control dial for headlamp beam adjustment in the **—** position, no gear engaged or selector lever in the **N** position (automatic gearbox), tourist light deactivated.

- Switch on the ignition.

Within 10 seconds of the ignition being switched on:

- Turn the light switch to the  position » page 59, *Switching the light on/off*.
- Engage reverse gear (manual gearbox) or move the selector lever to the **R** position (automatic gearbox),
- Turn the headlamp beam adjustment dial from **—** to **‡** » page 60.

Deactivating tourist light

Before deactivating the tourist light, the following conditions must be met.

Ignition switched off, light switched off (light switch in position **O**), control dial for headlamp beam adjustment in the **‡** position, no gear engaged or selector lever in the **N** position (automatic gearbox), tourist light activated.

- Switch on the ignition.

Within 10 seconds of the ignition being switched on:

- Turn the light switch to the  position » page 59, *Switching the light on/off*.
- Engage reverse gear (manual gearbox) or move the selector lever to the **R** position (automatic gearbox),
- Turn the headlamp beam adjustment dial from **‡** to **—** » page 60.

Further information » page 118, *Headlights*. ▶

i Note

When the "tourist light" mode is active, the warning light  flashes for 10 seconds each time the ignition is switched on.

Hazard warning light system



Fig. 44
Dash panel: Button for hazard warning light system

 Read and observe  on page 59 first.

➤ Press the  » Fig. 44 button.

All the turn signal lights on the vehicle flash at the same time when the hazard warning light system is switched on. The warning light for the turn signals and the warning light in the button also flash at the same time. The hazard warning light system can also be operated if the ignition is switched off.

The hazard warning light system will switch on automatically if one of the airbags is deployed.

! CAUTION

Switch on the hazard warning light system if, for example, the following occurs.

- You encounter a traffic jam.
- The vehicle has broken down.

Parking lights

 Read and observe  on page 59 first.

Switching on the parking light $P \leq$

- Switch off the ignition.
- Pull the turn signal stalk » Fig. 42 on page 61 upwards or downwards - the side light on the right or left side of the vehicle is switched on.

Switching on the side lights on both sides $\Rightarrow \leq$

- Turn the light switch » Fig. 40 on page 59 to the $\Rightarrow \leq$ position and lock the vehicle.

i Note

- The parking light $P \leq$ can only be activated if the ignition is switched off.
- If the right or left turn signal light has been switched on and the ignition is switched off, the parking light is not automatically switched on.

Interior lights

Introduction

This chapter contains information on the following subjects:

Interior lighting - version 1	63
Interior lighting - version 2	64
Illuminated storage compartment on the passenger side	64
Luggage compartment light	64

Interior lighting - version 1

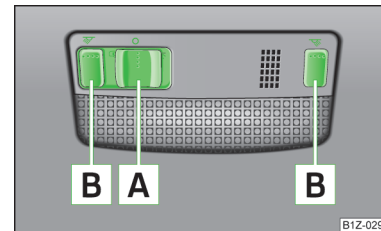



Fig. 45
Interior lighting - version 1

Positions of sliding switch **A** » Fig. 45.

-  Switch on
- 0** Switch off (middle position)
-  Control with the door contact switch

The reading lights can be turned on or off by pressing switch **B** » Fig. 45. ▶

If control of the lights by the door contact switch is enabled (switch **A** » Fig. 45 is in the ☞ position), **the light will come on** when one of the following occurs.

- The vehicle is unlocked.
- One of the doors is opened.
- The ignition key is removed.

If control of the lights by the door contact switch is enabled (switch **A** » Fig. 45 in the ☞ position), **the light will go off** when one of the following occurs.

- The vehicle is locked.
- The ignition is switched on.
- About 30 seconds after all the doors have been closed.

If a door remains open, or if switch **A** » Fig. 45 is in the ☞ position, the interior light goes out after 10 minutes to prevent the vehicle battery from discharging.

Interior lighting - version 2

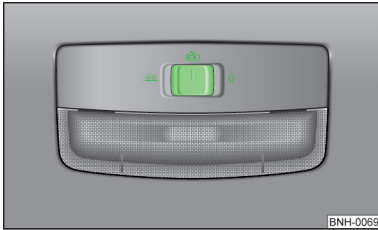

Fig. 46
Interior lighting - version 2

Slide switch positions » Fig. 46.

- ☛ Switch on
- 0 Switch off
- ☞ Control by the door contact switch (middle position)

The same principles apply for interior lighting version 2 as for » page 63, *Interior lighting - version 1*.

Illuminated storage compartment on the passenger side

- When opening the flap of the storage compartment on the front passenger side the lighting in the storage compartment comes on.
- The light switches on automatically when the parking light is switched on and goes out when the flap is closed.

Luggage compartment light

The light comes on automatically when the boot lid is opened. If the tailgate remains open for more than 10 minutes, the luggage compartment light switches off automatically.

Visibility

Introduction

This chapter contains information on the following subjects:

Rear window heater	64
Sun visors	65
sunshade	65

Rear window heater



Fig. 47
Button for rear window heater

- The rear window heater is switched on or off by pressing the  button » Fig. 47, the warning light in the switch comes on or goes out.

The rear window heater can only be switched on when the engine is running.

The rear window heater **switches off** automatically after approximately 7 minutes.

For the sake of the environment

The heating should be switched off as soon as the window is de-iced or free from mist. The reduced current consumption will have a favourable effect on fuel economy » page 116, *Saving electrical energy*.

i Note

If the on-board voltage drops, the rear window heater switches off automatically, in order to provide sufficient electrical energy for the engine control » [page 156](#), *Automatic load deactivation*.

Sun visors

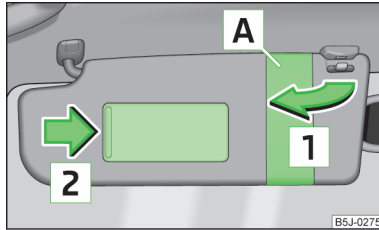

Fig. 48
Sun visor: swivelling out

The sun visor for the driver or front passenger can be pulled out of the fixture and swivelled towards the door in the direction of arrow [1] » [Fig. 48](#).

The vanity mirrors in the sun visors are provided with covers. Push the cover in the direction of the arrow [2].

The purpose of the strap [A] is to store small, light objects, such as a notepad, etc.

! WARNING

The sun visors must not be swivelled towards the side windows in the deployment area of the head airbags if any objects, such as ball-point pens, etc. are attached to them. This might result in injuries to the occupants if the head airbag is deployed.

sunshade

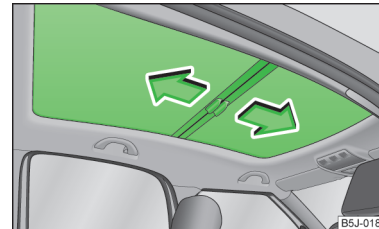

Fig. 49
Sun screen

The sunshade can be opened or closed manually » [Fig. 49](#).

Please pay attention to the following points if you wish to transport luggage or other items on the roof of your vehicle » [page 80](#), **!** in section *Introduction*.

! WARNING

When operating the sunshade, proceed with caution to avoid causing crushing injuries - risk of injury!

Windscreen wipers and washers

! Introduction

This chapter contains information on the following subjects:

Windscreen wiper and washer	66
Headlight cleaning system	67
Replacing the windscreen wiper blades	67
Replacing the rear window wiper blade	67

The windscreen wipers and the windscreen washer system only operate when the ignition is switched on.

The rear window is wiped once automatically if the windscreen wipers are on when reverse gear is selected.

Top up with windscreen wiper fluid » [page 147](#).

! WARNING

- Properly maintained windscreen wiper blades are essential for clear visibility and safe driving » page 67.
- Do not use the windscreen washer system at low temperatures, without heating the windscreen beforehand. Otherwise the window cleaner could freeze on the windscreen and restrict the view to the front.
- Replace the windscreen wiper blades once or twice a year for safety reasons. These can be purchased from a ŠKODA Partner.

! CAUTION

- In cold temperatures and during the winter, check before the journey or before switching on the ignition that the wiper blades are not frozen to the windscreen. If the windscreen wipers are switched on when the blades are frozen to the windscreen, this may damage both the blades and windscreen wiper motor!
- If the ignition is switched off while the windscreen wipers are switched on, the windscreen wipers will continue wiping in the same mode after the ignition is turned back on. The windscreen wipers could freeze up in cold temperatures between the time the ignition was turned off and when it was turned back on again.
- Carefully detach frozen wiper blades from the front or rear window.
- Remove snow and ice from the windscreen wipers before driving.
- If the windscreen wipers are handled carelessly, there is a risk of damage to the windscreen.

i Note

- The windscreen washer nozzles for the windscreen are heated when the engine is running and the outside temperature is less than approx. +10 °C.
- The content of the windscreen washer fluid reservoir is 3.5 litres. On vehicles fitted with the headlight cleaning system, the volume is around 5.4 litres.
- The wiper blades should be cleaned on a regular basis with a windscreen cleaner to avoid any smears. The wiper blades should be cleaned with a sponge or cloth if they are heavily soiled by insect residues, for example.

Windscreen wiper and washer

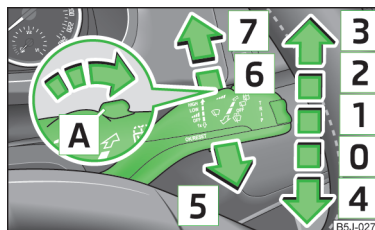

Fig. 50
Operating lever: Windscreen wipers and washer settings

📖 Read and observe ! and ! on page 66 first.

Control stalk positions » Fig. 50.

- 0 Wipers off
- 1 Interval windscreen wiping
- 2 Slow windscreen wiping
- 3 Rapid windscreen wiping
- 4 Single windscreen wipe (spring-loaded position)
- 5 Automatic wipe/wash for windscreen (spring-loaded position)
- 6 Wiping the rear window (the windscreen wiper wipes at regular intervals after a few seconds)
- 7 Automatic wipe/wash for the rear window (spring-loaded position)
- A Switch for setting the desired interval between the individual windscreen wipes (1 Interval windscreen wiping)

Automatic wipe/wash for windscreen

The wash system operates immediately, the windscreen wipers wipe somewhat later.

Releasing the lever will stop the windscreen washer while the wipers continue for another 1 to 3 wiper strokes (depending on the period the windscreen has been sprayed).

Automatic wipe/wash for the rear window

The wash system operates immediately, the wiper wipes somewhat later.

Releasing the lever will stop the washer while the wipers continue for another 1 to 3 wiper strokes (depending on the period the window has been sprayed).

The lever will stay in position after releasing it 6.

Headlight cleaning system

Read and observe **!** and **!** on page 66 first.

The headlights are sprayed briefly if the low beam or main beam are switched on and the windscreen wiper stalk is pulled to position **5** » Fig. 50 on page 66. To clean the headlights, the windshield is also sprayed after every five squirts.

You should remove stubborn dirt (such as insect residues) from the headlight lenses at regular intervals, for example when refuelling. The following guidelines must be observed » page 138, *Headlight lenses*.

To ensure the proper operation of the cleaning system during the winter, any snow should be removed from the washer nozzle fixtures and ice should be cleared with a de-icing spray.

CAUTION

Never remove the nozzles from the headlight cleaning system by hand - there is risk of damage.

Replacing the windscreen wiper blades

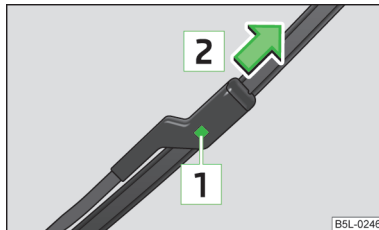

Fig. 51
Windscreen wiper blade

Read and observe **!** and **!** on page 66 first.

Removing the wiper blade

- › Lift the windscreen wiper arm away from the windscreen.
- › Press the locking button **1** » Fig. 51 and remove the wiper blade in the direction of arrow **2**.

Fitting the wiper blade

- › Push the wiper blade in until it latches on the stop.
- › Check that the wiper blade is correctly attached.
- › Fold the wiper arms back to the windscreen.

Windshield wiper blades in proper condition are essential to obtain good visibility. Wiper blades should not be allowed to become dirtied by dust, insect remains and preserving wax.

Juddering or smearing of the wiper blades could then be due to wax residues left on the windshield by vehicle washing in automatic vehicle wash systems. It is therefore important to **clean** and degrease the lips of the windshield wiper blades after **every pass through the automatic vehicle wash system**.

Replacing the rear window wiper blade

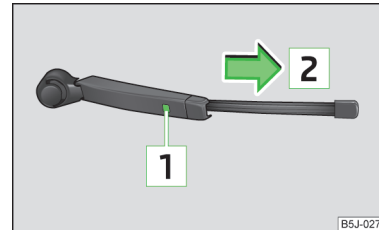

Fig. 52
Rear window wiper blade

Read and observe **!** and **!** on page 66 first.

Removing the wiper blade

- › Raise the wiper arm away from the window » Fig. 52.
- › Tilt the wiper blade to the stop in the direction of the wiper arm.
- › Hold the upper part of the wiper arm and unlock the securing mechanism **1**.
- › Remove the wiper blade in the direction of the arrow **2**.

Fitting the wiper blade

- › Push the wiper blade in until it latches on the stop.
- › Check that the wiper blade is correctly attached.
- › Fold the wiper arm back to the windscreen.

Rear window

Introduction

This chapter contains information on the following subjects:

Manually dimmed rear-view mirror	68
Exterior mirrors	68 ▶

! WARNING

- Make sure that the mirror is not covered by ice, snow, condensation or other objects.
- Convex (curved outward) or aspheric exterior mirrors increase the field of vision. They do, however, make objects appear smaller in the mirror. These mirrors are therefore only of limited use for estimating distances to the following vehicles.
- Whenever possible use the interior mirror for estimating the distances to the following vehicles.

Manually dimmed rear-view mirror

 Read and observe **!** on page 68 first.

Basic setting

➤ Adjust the lever at the lower edge of the mirror towards the windshield.

Dimming mirror

➤ Pull the lever on the lower edge of the mirror away from the windscreen.

Exterior mirrors

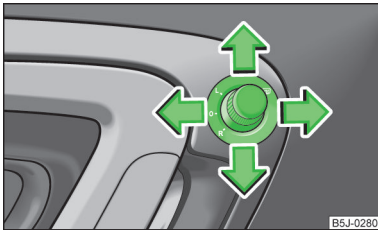



Fig. 53
Inner part of door: Knob for the mirrors

 Read and observe **!** on page 68 first.

The knob can be moved into the following positions.

- L Adjust the left mirror
- R Adjust the right mirror
- 0 Switch off mirror control
-  Mirror heater

The mirror can be adjusted to the desired position by moving the knob in the direction of the arrow » Fig. 53.

The movement of the mirror surface follows the movement of the rotary knob.

Folding in the exterior mirrors

The whole exterior mirror can be manually folded towards the side windows. Restore it to its original position, it should be folded back from the side window until it audibly clicks into place.

i Note

- The exterior mirror heater only operates when the engine is running.
- Do not touch the surface of the exterior mirrors if the exterior mirror heater is switched on.
- If the power setting function fails at any time, the exterior mirrors can be set by hand by pressing on the edge of the mirror surface.
- Contact a specialist garage if there is a fault with the power setting function for the exterior mirrors.

Seats and stowing

Front seats

Introduction

This chapter contains information on the following subjects:

Adjusting the front seats	69
Front seat heating	69

The driver's seat should be adjusted in such a way that the pedals can be fully pressed to the floor with slightly bent legs.

The seat backrest on the driver's seat should be adjusted in such a way that the upper point of the steering wheel can be easily reached with slightly bent arms.

Correct adjustment of the seats is particularly important for the following reasons.

- Reaching the controls safely and quickly.
- A relaxed and fatigue-free body position.
- **Achieving the maximum protection offered by the seat belts and the airbag system.**

! WARNING

- Only adjust the driver's seat when the vehicle is stationary – risk of accident!
- Caution when adjusting the seat! You may suffer injuries or bruises as a result of adjusting the seat without paying proper attention.
- Never carry more people than the number of seats in the vehicle.
- Do not carry any objects on the front passenger seat except objects designed for this purpose (e.g. child seat) – risk of accident!

i Note

After a certain time, play can develop within the adjustment mechanism of the backrest angle.

Adjusting the front seats

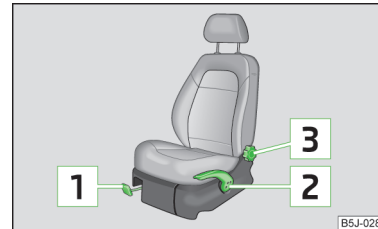

Fig. 54
Control elements at the seat

Read and observe ! on page 69 first.

Adjusting a seat in a forward/back direction

- Pull lever **1** » Fig. 54 up and push the seat into the desired position.
- Release the lever **1** and push the seat until the lock clicks into place.

Adjusting height of seat

- To lift the seat, pull or pump lever **2** » Fig. 54 upwards.
- To lower the seat, push or pump the lever **2** downwards.

Adjusting the angle of the seat backrest

- To adjust the angle of the backrest, relieve any pressure from the seat backrest (do not lean on it) and turn handwheel **3** » Fig. 54.

Front seat heating



Fig. 55
Rocker switch for front seat heating

Read and observe ! on page 69 first.

The seat backrests and seats can be heated electrically. ▶

- › Switch the front seat heating to 25 % or 100 % power by pressing rocker switch at position **1** or **2** » Fig. 55.
- › To switch off the heating shift the rocker switch into the horizontal position.

! WARNING

If, as an occupant, you have a subdued pain and/or temperature sensitivity, e.g. through medication, paralysis or because of chronic illness (e.g. diabetes), we recommend not to use the seat heating. This can lead to burns on the back, the posterior and the legs which are difficult to heal. If the seat heating is used, we recommend to make regular breaks in your journey when driving long distances, so that the body can recuperate from the stress of the journey. Please consult your doctor, who can evaluate your specific condition.

! CAUTION

- Do not kneel on the seats or otherwise apply pressure at specific points to avoid damaging the heating elements for the seat heaters.
- Do not turn on the seat heater if seats are not occupied.
- Do not switch on the seat heating if the seats have objects attached to or placed on them, for example a child seat, a bag, etc. A fault of the heating elements in the seat heating can occur.
- If additional seat covers or protective covers are attached to the seats, do not turn on the seat heater - there is a risk of damaging the seat covers and seat heating.
- Do not clean the seats using moisture » page 141, *Seat covers*.

i Note

- The seat heating should only be switched on when the engine is running. This has a significant effect of saving on the battery capacity.
- If the on-board voltage drops, the seat heating is switched off automatically, in order to provide sufficient electrical energy for the engine control » page 156, *Automatic load deactivation*.

Rear seats

Introduction

This chapter contains information on the following subjects:

Setting theSetting the seats in the longitudinal direction	70
Setting theinclination of the seat backrest	70
Fold downseat backrest and seat fold down completely	71

70 Operation

Unlocking and removing seats	71
Adjusting seats in crosswise direction	72
Folding the rear seats into the starting position	72

Setting theSetting the seats in the longitudinal direction

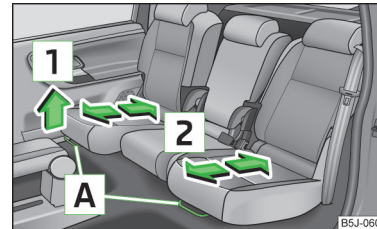

Fig. 56
Adjusting seats in forward/back direction

- › Pull lever **A** in the direction of arrow **1** and move the seat to the desired position in the direction of arrow **2** » Fig. 56.

Setting theinclination of the seat backrest

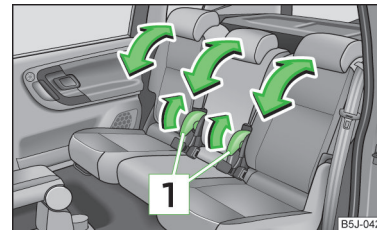

Fig. 57
Adjusting the seat backrest

- › Pull the lever **1** » Fig. 57 and adjust the required inclination of the seat backrest.

! WARNING

Check for yourself that the seat backrest is engaged by pulling on it.

Fold downseat backrest and seat fold down completely

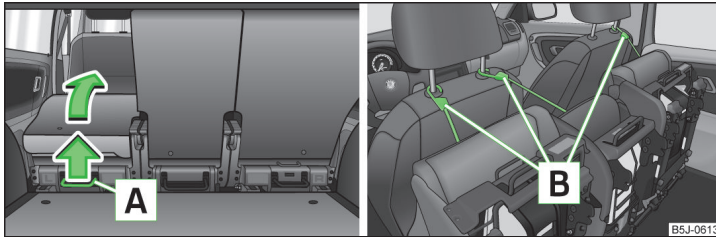

Fig. 58 Fold seat fully forwards/lock folded forward seats

Folding the seat backrest forwards

- Put the belt tongue into the opening on the respective side of the vehicle - safety position.
- Remove the head restraint from the rear middle seat » page 72, *Head restraints*.
- Push the outer rear seats towards the rear as far as they will go » page 70, *Setting the seats in the longitudinal direction*.
- Pull lever **1** » Fig. 57 on page 70 and fold the seat backrest completely forwards.
- Pull lever **A** » Fig. 58 up and fold the seat forwards fully.

Folding seats fully forwards and locking them

- If the outer rear seat is fully folded forward, push it towards the rear as far as it can go.
- Pull lever **A** » Fig. 58 up and fold the seat forwards fully.
- Secure the folded forward seat with the aid of the fixing belt **B** to a guide rod of the head restraint in the front seat » Fig. 58.

! WARNING

Immediately lock the folded forward seat with the aid of the fixing belt to a guide rod of the head restraint for the front seat - risk of injury.

! CAUTION

- If the outer seat is not in the rear end position when folding forward, damage can occur to the locking bolts when unlocking the seat.
- Only keep the seats in the folded forward position for as long as necessary to transport cargo - there is a risk of damaging the front seat backrests. The seats must be folded back once the cargo has been transported.

Unlocking and removing seats

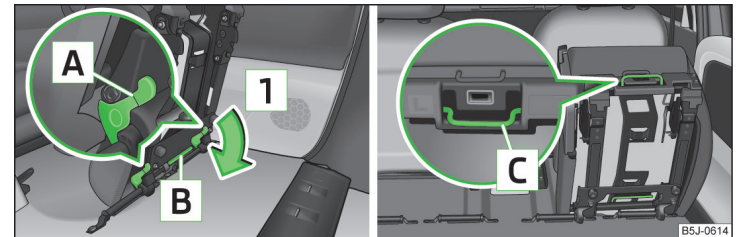

Fig. 59 Unlocking the folded forward seat/carrying handles on the seat cushion

- Fold the seat forward » page 71, *Fold downseat backrest and seat fold down completely*.
- Unlock the folded seat by pressing seat locks **A** » Fig. 59 in the direction of arrow **1**.
- Remove the seat using the carrying handles **B** or **C**.

i Note

The outer seats are not mutually interchangeable. In the rear area the left seat is marked with the letter L and the right seat with the letter R.

Adjusting seats in crosswise direction

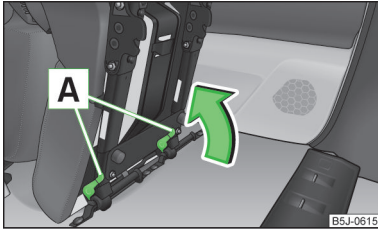

Fig. 60
Locking seats

- Remove the middle seat » [page 71, Unlocking and removing seats.](#)
- Fold the outer seat forwards » [page 71, Fold down seat backrest and seat fold down completely](#) and unlock » [Fig. 59 on page 71.](#)
- Move the folded forward and unlocked seat on the guide towards the middle of the vehicle up to the stop.
- Lock the folded seat by pressing seat locks **A** » [Fig. 60](#) in the direction of the arrow.

Folding the rear seats into the starting position

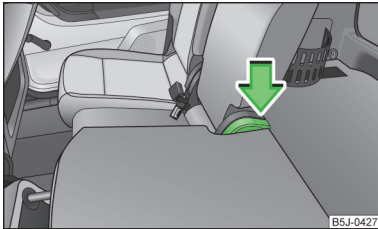

Fig. 61
Folding the seat backrest back into position

- If the seat has been removed, first position it on the guide and lock it in place » [Fig. 60 on page 72.](#) Pull the seat upwards to ensure that the seat is locked correctly.
- Fold the seat in the horizontal position until it can be heard to click. Check for yourself that the seat can no longer be lifted by pulling it up.
- Press the lever » [Fig. 61](#) and fold back the seat backrest. Check for yourself that the seat backrest is engaged by pulling on it.
- Remove the tongue of the lock from the safety position.

! WARNING

- The belt locks must be in their original position after folding back the seat cushions and backrests - they must be ready to use.
- The seat backrests must be securely latched in position so that no objects from the luggage compartment can slip into the passenger compartment under sudden braking – there is a risk of injury.
- When folding the seat backrest always make sure that it has safely locked into position, this is confirmed by the position and a visible marking on the cover of the lever.

Head restraints

📖 Introduction

This chapter contains information on the following subjects:

headrest adjust _____ 73

Best protection is achieved if the top edge of the head restraint is at the same level as the upper part of your head.

The head restraints must be adjusted to match the size of the seat occupant. Correctly adjusted head restraints together with the seat belts offer effective protection for the occupants » [page 9.](#)

! WARNING

- The head restraints must be correctly adjusted in order to offer effective protection for the occupants in the event of an accident.
- Never drive with the head restraints removed - risk of injury.
- If the rear seats are occupied, the rear head restraint must not be in the lower position.

headrest adjust

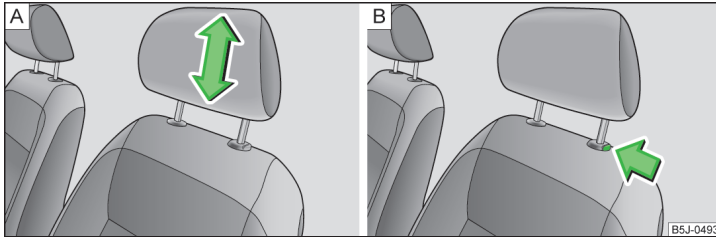

Fig. 62 Head restraint: adjusting/removing

Read and observe on page 72 first.

Setting height

- ▶ Grasp the side of the head restraint with both hands and push it upwards as required » Fig. 62 - [A].
- ▶ To move the head restraint downwards, press and hold the safety button » Fig. 62 - [B] with one hand and push the head restraint down with the other hand.

Removing/installing

- ▶ Pull the head restraint out of the seat backrest as far as the stop.
- ▶ Press the locking button in the direction of the arrow » Fig. 62 - [B] and pull the head restraint out.
- ▶ To re-insert the head restraint, push it far enough down into the seat backrest until the locking button clicks into place.

Boot

Introduction

This chapter contains information on the following subjects:

Class N1 vehicles	74
Fastening elements	74
Folding hooks	74
Fixing nets	75
Fixing floor covering of the luggage compartment	75

Boot cover	75
Net partition	76

Please observe the following for the purpose of maintaining good handling characteristics of your vehicle:

- ▶ Distribute loads as evenly as possible.
- ▶ Place heavy objects as far forward as possible.
- ▶ Attach the items of luggage to the lashing eyes or using the fixing net » page 74.

In the event of an accident, even small and light objects gain so much kinetic energy that they can cause severe injuries.

The magnitude of the kinetic energy is dependent on the speed at which the vehicle is travelling and the weight of the object.

Example: In the event of a frontal collision at a speed of 50 km/h, an object weighing 4.5 kg produces energy corresponding to 20 times its own weight. This means that it results in a weight of approx. 90 kg " " .

WARNING

- Store the objects in the boot and attach them to the lashing eyes.
- Loose objects can be thrown forward during a sudden manoeuvre or in case of an accident and can injure the occupants or other road users.
- Loose objects could hit a deployed airbag and injure occupants - there is a risk of death.
- Please note that transporting heavy objects alters the handling properties of the vehicle due to the displacement of the centre of gravity - risk of accident! The speed and style of driving must be adjusted accordingly.
- If the items of luggage or objects are attached to the lashing eyes with unsuitable or damaged lashing straps, injuries can occur in the event of braking manoeuvres or accidents. To prevent items of luggage from being thrown forward, always use suitable lashing straps which must be firmly attached to the lashing eyes.
- The transported items must be stowed in such a way that no objects are able to slip forward on sudden driving or braking manoeuvres - risk of injury!
- When transporting fastened objects which are sharp and dangerous in the boot that has been enlarged by folding the rear seats forward, ensure the safety of the passengers transported on the other rear seats » page 11, *Correct seated position for the passengers in the rear seats.*

Fixing nets

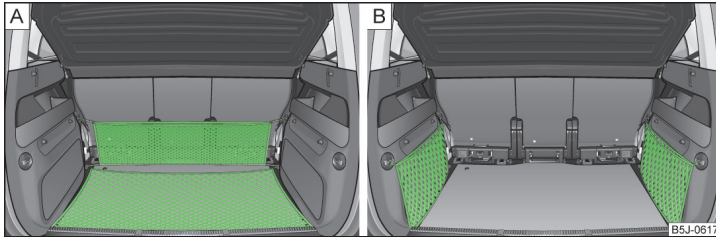

Fig. 65 Fixing net: double horizontal pocket, floor fixing net/double vertical pockets

Read and observe **!** and **!** on page 73 first.

Fixing examples of the fixing net as a double horizontal pocket, floor fixing net » Fig. 65 - **A** and double vertical pockets » Fig. 65 - **B**.

! WARNING

Do not exceed the maximum permissible load of the fixing nets. Heavy objects are not secured sufficiently – risk of injury!

! CAUTION

- The maximum permissible load of the fixing nets is 1.5 kg.
- Do not place any sharp objects in the nets – risk of net damage.

Fixing floor covering of the luggage compartment

Read and observe **!** and **!** on page 73 first.

You can fix the raised floor cover between the backrests and the luggage compartment cover, if one needs to reach the spare wheel.

Boot cover

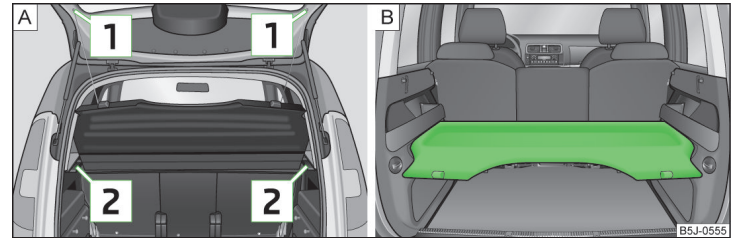

Fig. 66 Removing the luggage compartment cover/luggage compartment cover in the lower position

Read and observe **!** and **!** on page 73 first.

The boot cover can be removed if you wish to transport bulky goods.

- Unhook support straps **1** » Fig. 66.
- Fold the luggage compartment cover forwards a little.
- Remove the cover from the holders **2** by pulling towards the rear, or by lightly knocking on the underside of the cover in the area between the holders.
- To reinstall, first of all push the luggage compartment cover into the holders **2** and then hook the support straps **1** on the boot lid.

The luggage compartment cover can also be fitted in the lower position on the supporting elements » Fig. 66 - **B**.

In this position you can store smaller objects up on the luggage compartment cover up to a total weight of 2.5 kg.

! WARNING

No objects should be placed on the boot cover, the vehicle occupants could be endangered if there is sudden braking or the vehicle collides with something.

! CAUTION

Please ensure that the heating elements for the rear window heater are not damaged as a result of objects placed in this area.

i Note

When opening the boot lid, the luggage compartment cover is lifted up at the same time- risk that objects placed in this area can slip forward!

Net partition

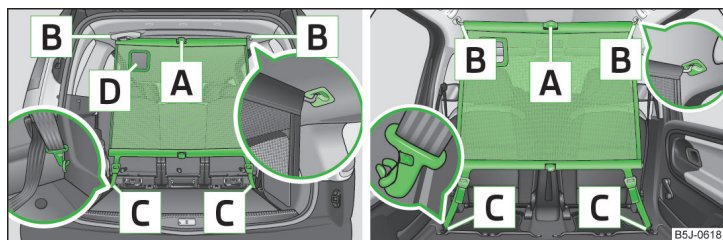

Fig. 67 Using the net partition behind the front/rear seats

Read and observe **i** and **j** on page 73 first.

The net partition can either be installed behind the rear seats or behind the front seats.

Installing the net partition behind the rear seats

- Remove the boot cover » page 75, *Boot cover*.
- Remove the net partition from the bag.
- Unfold both parts of the cross rod until they are heard to engage.
- First insert the rod into the mount **B** » Fig. 67 on one side and push it forwards. In the same way, insert the cross rod into the mount **B** on the other side of the vehicle.
- Hang the carabiners **C** at the ends of the belt into the lashing eyes behind the rear seats.
- Pull the belt through the tensioning clasp on both sides- first of all on the one side and then on the other side.

Removing the net partition

- Undo the belts on both sides and unhook the carabiners **C** » Fig. 67.
- Push the cross rod first of all on the one side and then on the other side towards the rear.
- Remove the cross rod from the mounts **B**.

Packing the net partition

- Press the red button on hinge **A** » Fig. 67 - the hinge breaks.

- Put the net partition folded together in the bag and close it.
- Attach the bag with the aid of the plastic carabiners to the eyes on the left and right boot trim panel.

Installing and removing the net partition behind the rear seats is carried out in the same way as behind the rear seats. Use the fixing eyes behind the front seats in order to attach the carabiners **C** » Fig. 67. To enlarge the boot, the rear seats can be removed.

Installing and removing the net partition behind the rear seats with variable loading floor » page 76 is carried out in the same way as behind the rear seats without variable loading floor. To attach the carabiners **C** » Fig. 67, use the lower fixing eyes on the fixing wedges in the front area of the variable loading floor.

The opening **D** in the net partition is designed to pass through the three-point seat belt » page 15, *Seat belt for the rear middle seat*.

Variable loading floor in the luggage compartment (Estate)

Introduction

This chapter contains information on the following subjects:

Dividing up the luggage compartment with variable loading floor	77
Removing and refitting the variable loading floor	77
Removing/installing the carrier rails	77
Removing/installing the lateral carrier rail and fixing wedges	78

The variable loading floor makes handling of bulky items of luggage easier.

! CAUTION

The maximum permissible load of the variable loading floor is 75 kg.

i Note

The room under the variable loading floor can be used to stow objects.

Dividing up the luggage compartment with variable loading floor

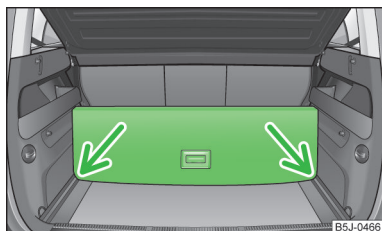

Fig. 68
Dividing the boot

Read and observe **!** on page 76 first.

- › Lift up the part of the loading floor with the grip and secure it by sliding it into the grooves marked with the arrows » Fig. 68.

Removing and refitting the variable loading floor

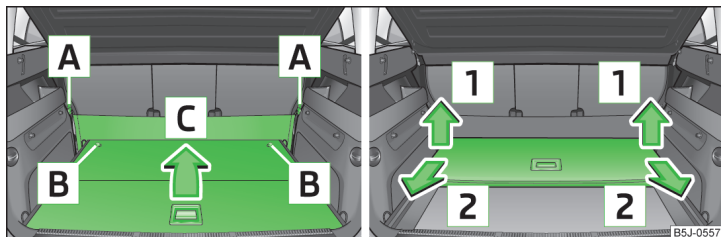

Fig. 69 Fold up variable loading floor/remove

Read and observe **!** on page 76 first.

Removing

- › Unhook the loops **A** » Fig. 69 of the elastic partition from the fixing points.
- › Unlock the variable loading floor by turning the locking bolts **B** to the left by around 180°.
- › Fold up the variable loading floor by moving it in the direction of the arrow **C**.
- › Fold up the variable loading floor in the direction of the arrow **1** and remove by pulling in the direction of the arrow **2**.

Fitting

- › Fold up the variable loading floor and place it on the carrier rails.
- › Fold out the variable loading floor.
- › Lock the variable loading floor by turning the locking bolts **B** » Fig. 69 to the right through around 180°.
- › Secure the loops **A** of the elastic partition to the fixing points.

! WARNING

Ensure that the carrier rails and variable loading floor are correctly fastened when installing the variable loading floor. If this is not the case, there is a risk of injury for the occupants.

Removing/installing the carrier rails

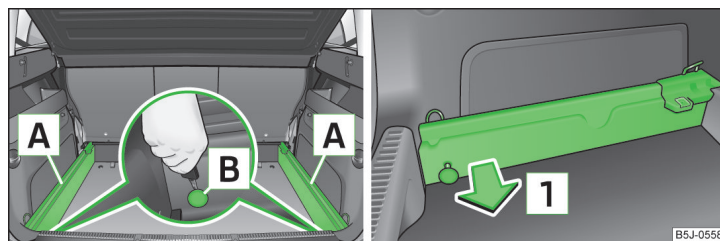

Fig. 70 Boot: Slacken check points/remove carrier rails

Read and observe **!** on page 76 first.

Removing

- › Undo the securing points **B** » Fig. 70 on the carrier rails using the vehicle key or a flat screwdriver.
- › Remove the carrier rail **A** and remove by pulling in the direction of arrow **1**. The carrier rail on the other side of the luggage compartment can be removed in the same way.

Fitting

- › Position the carrier rails on the sides of the boot.
- › Press the securing point **B** » Fig. 70 on each carrier rail to the stop.
- › Check the attachment of the carrier rails by pulling it.

! WARNING

Ensure that the carrier rails and variable loading floor are correctly fastened when installing the variable loading floor. If this is not the case, there is a risk of injury for the occupants.

Removing/installing the lateral carrier rail and fixing wedges

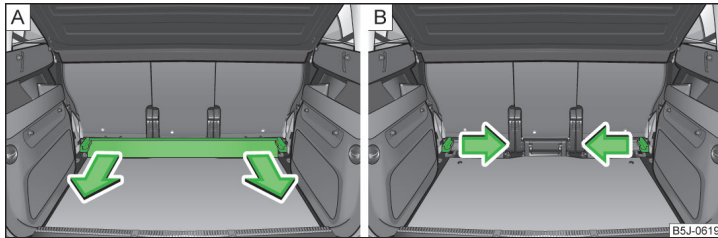

Fig. 71 Boot: Take out lateral carrier rail/Take out fixing wedges

📖 Read and observe ! on page 76 first.

Removing

- Remove the lateral carrier rail » Fig. 71 - A and remove by pulling in the direction of arrow.
- Remove the mounting wedges by pulling in the direction of the arrow » Fig. 71 - B.

Fitting

- Put the fixing wedge on the fixing points and press in the direction of the sides of the luggage compartment up to the stop.
- Insert the lateral carrier rail at an angle to the fixing wedges and press it up to the stop.
- Check how well the lateral carrier rail is fastened by pulling on it.

Bicycle carrier in the luggage compartment

📖 Introduction

This chapter contains information on the following subjects:

- Install cross member _____ 78
- Install bicycle carrier _____ 79

78 Operation

- Put bicycle into the bicycle carrier _____ 79
- Secure the stability of the bicycles with a belt _____ 79

! WARNING

When transporting bicycles, ensuring the safety of the passengers is paramount.

! CAUTION

Take care handling the bicycle - there is a risk of damaging the vehicle.

Install cross member

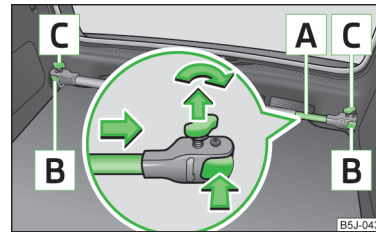

Fig. 72
Install cross member

📖 Read and observe ! and ! on page 78 first.

- Remove the luggage compartment cover » page 75.
- Fold the rear seats forward, remove » page 71.
- Undo the securing bolts C » Fig. 72 and remove a little to unlock the holders B.
- Place the cross member A with the fixed part onto the right lashing eye and then place it on the left lashing eye with the removable part of the cross member A.
- Press the holders B until they latch. Tighten the securing screws C.
- Check how well the cross member is fastened by pulling on it.

Install bicycle carrier

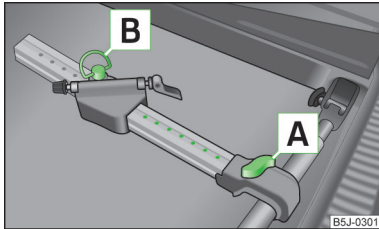

Fig. 73
Install bicycle carrier

Read and observe **!** and **!** on page 78 first.

- Position the approved bicycle carrier on the cross member.
- Remove bolt **A** » Fig. 73 a little and push the frame side rail (aluminium part) towards the cross member until the socket latches.
- Insert the screw **A** into the nut.
- Undo the screw **B** on the movable part of the bicycle carrier and unscrew.
- Place the movable part of the fixture, depending on the size of the vehicle, in one of the possible positions so that the bicycle does not touch the boot lid. We recommend to place the moveable part of the fixture in such a position that 7 holes are visible between the screw **A** and the moveable part.
- Insert the screw **B** into the desired position and tighten.

Put bicycle into the bicycle carrier

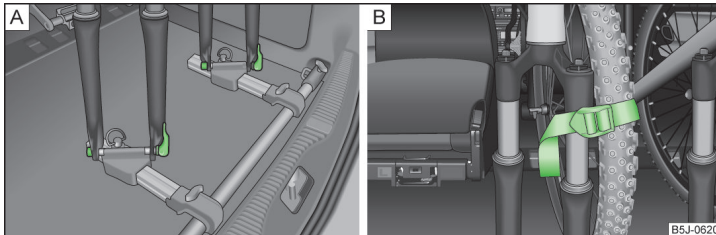

Fig. 74 Put in the bicycle/example fastening the front wheel

Read and observe **!** and **!** on page 78 first.

- Remove the front wheel of the bicycle before installing it.

- Slacken the quick tension jack on the fixing axle of the bicycle carrier and adjust according to the width of the bicycle fork.
- Place the bicycle fork on the fixing axle and tighten with the quick release lever » Fig. 74 - **A**.
- Position the left pedal of the bicycle forward, in order to attach the front wheel more easily.
- Undo the bolt **A** » Fig. 73 on page 79 and push the bicycle carrier to the left together with the mounted bicycle to prevent a collision between the handlebars and the side window of the luggage compartment.
- Carefully guide the boot lid downwards without letting go of it. Check whether there is sufficient room between the steering bars and the rear window. If necessary, adjust the position of the movable part of the bicycle carrier to prevent a collision » page 79.
- It is best to store the removed front wheel between the left crank and the bicycle frame, attach it with a strap to the front fork » Fig. 74 - **B** or to one of the fixing points.
- The second carrier is installed and the bicycle is secured in a similar way.

Secure the stability of the bicycles with a belt

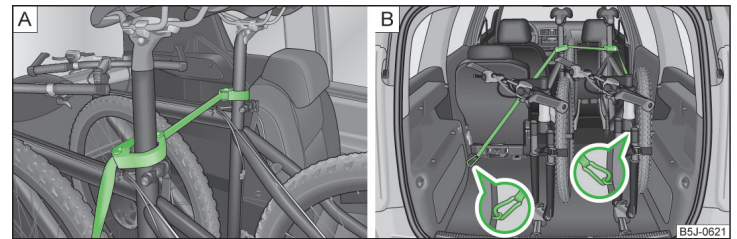

Fig. 75 Securing bicycles

Read and observe **!** and **!** on page 78 first.

- To slacken the rubber part of the clamp, push both parts against each other and open the clamp.
- Position the clamp with the rubber part to the front (in direction of travel) as low down on the seat post as possible and lock it » Fig. 75 - **A**.
- When transporting two bicycles, stretch the belt » Fig. 75 - **A** between the saddles by moving the bicycles apart.
- Hook the carabiners on the ends of the belt into the lashing eyes behind the rear seats » Fig. 75 - **B**.

- Pull the belt through the tensioning clasps on both sides in turn.
- If necessary, you can correct the position of the bicycles in the vehicle.

Roof rack system

Introduction

This chapter contains information on the following subjects:

Roof load _____ 80

WARNING

- The transported items on the roof rack must be securely attached – risk of accident!
- Always secure the load with appropriate and undamaged lashing straps or tensioning straps.
- Distribute the load evenly over the roof rack system.
- Transporting heavy or large objects on the roof rack alters the handling properties of the vehicle due to the displacement of the centre of gravity or the increased wind exposure area – risk of accident! The style of driving and speed must therefore be adapted to the current circumstances.
- Avoid abrupt and sudden driving/braking manoeuvres.
- Adjust the speed and driving style to the visibility, weather, road and traffic conditions.
- The permissible roof load, permissible axle loads and permissible total vehicle weight must not be exceeded under any circumstances – risk of accident!

CAUTION

- Only roof racks from the ŠKODA Original Accessories range should be used.
- The fitting instructions supplied with the roof luggage rack system must be observed when handling roof racks.
- Ensure that the boot lid does not hit the roof load when opened.
- The height of the vehicle changes after mounting a roof luggage rack system and the load that is secured to it. Compare the vehicle height with available clearances, such as underpasses and garage doors.
- Always remove the roof luggage rack system before entering an automated car wash.
- Ensure the roof aerial is not impaired by the secured load.

For the sake of the environment

The increased aerodynamic drag results in a higher fuel consumption.

Note

If the vehicle is not factory-equipped with a roof rack, it can be purchased from the ŠKODA Original Accessories.

Roof load

 Read and observe  and  on page 80 first.

The maximum permissible roof load (including roof rack system) of **75 kg** and the maximum permissible total weight of the vehicle should not be exceeded.

The full permissible roof load cannot be used if a roof rack system with a lower load carrying capacity is used. In this case, the roof rack system must only be loaded up to the maximum weight limit specified in the fitting instructions.

Useful equipment

Introduction

This chapter contains information on the following subjects:

Cupholders _____	81
Ashtray _____	81
Cigarette lighter _____	82
12-volt power outlet _____	82
Clothes hook _____	83
Car park ticket holder _____	83

WARNING

- Do not place anything on the dash panel. These objects might slide or fall down while you are driving (under acceleration or when cornering) and could distract you from the traffic - there is a risk of an accident.
- Make sure that no objects from the centre console or from other storage compartments can get into the driver's footwell while you are driving. You would not be able to brake, operate the clutch pedal or accelerate - danger of causing an accident!
- Ash and cigarette or cigar stubs must only be discarded in ashtrays.

Cupholders

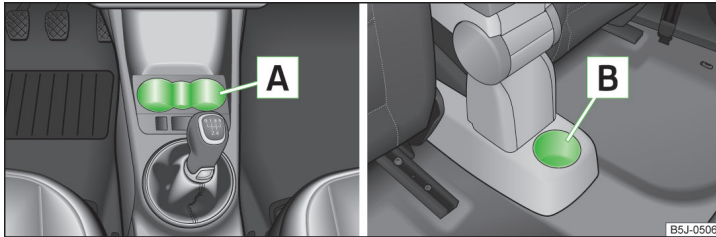

Fig. 76 Cup holder

Read and observe **!** on page 80 first.

Two beverage containers can be placed in the recesses **A** » Fig. 76.

One beverage container can be placed into the recess **B**.

! WARNING

- Never put hot cups in the cup holder. They may spill if the vehicle moves – there is a risk of scalding.
- No objects should be placed in the holders that might endanger the vehicle's occupants if the vehicle brakes suddenly or the vehicle is in collision.
- Do not use any cups or beakers made of fragile material (e.g. glass, porcelain). This could lead to injuries in the event of an accident.

! CAUTION

Do not leave open beverage containers in the cup holder during the journey. There is a risk of spilling e.g. when braking which may cause damage to the electrical components or seat upholstery.

Ashtray



Fig. 77 Centre console: Ashtray at the front/rear

Read and observe **!** on page 80 first.

The ashtray can be used for discarding ash, cigarettes, cigars and the like » **!**.

Removing

➤ Pull out the ashtray » Fig. 77 upwards.

Fitting

➤ Insert the ashtray vertically.

! WARNING

Never place flammable objects in the ashtray – risk of fire!

! CAUTION

When removing, do not hold the ashtray at the cover – risk of breakage.

Cigarette lighter

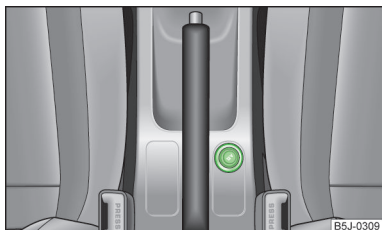

Fig. 78
Centre console: Cigarette lighter

Read and observe **!** on page 80 first.

Operation

- Press in the button in the cigarette lighter » Fig. 78.
- Wait until the button pops forward.
- Remove the cigarette lighter immediately and use.
- Place the cigarette lighter back into the socket.

The cigarette lighter also operates when the ignition is switched off or the ignition key withdrawn » **!**.

! WARNING

- Take care when using the cigarette lighter! Improper use of the cigarette lighter can cause burns.
- When leaving the vehicle, never leave people who are not completely independent, such as children, unattended in the vehicle. They could operate the igniter and burn themselves.

i Note

The cigarette lighter socket can also be used as a 12Volt socket for electrical appliances » page 82.

12-volt power outlet



Fig. 79
Boot: Power socket

Read and observe **!** on page 80 first.

The 12-volt electrical outlet (hereinafter referred to only as a power socket) is located in the front centre console » Fig. 78 on page 82 and in the luggage compartment » Fig. 79.

Use

- Remove the cover from power socket or cigarette lighter, or open the cover for the power socket.
- Connect the plug for the electrical appliance to the socket.

The power socket and any connected appliances can also be operated when the ignition is switched off or the ignition key is withdrawn » **!**.

! WARNING

- Improper use of the power sockets and the electrical accessories can cause fires, burns and other serious injuries. Therefore, when leaving the vehicle, never leave people who are not completely independent, such as children, unattended in the vehicle.
- If the connected electric device becomes too hot, switch it off and disconnect it from the power supply immediately.

! CAUTION

- The 12-volt power socket can only be used for connecting approved electrical accessories with a total power uptake of up to 120 watt.
- Never exceed the maximum power consumption, otherwise the vehicle's electrical system can be damaged.
- If electrical consumers are switched on when the engine is not running, this will cause the car battery to discharge – risk of battery discharge!
- Only use matching plugs to avoid damaging the 12-volt power socket. ▶

- Only use accessories that have been tested for electromagnetic compatibility in accordance with the applicable directives.
- Before turning the ignition on or off, and before starting the car, switch off the device connected to the 12-volt power socket to prevent any damage caused by voltage fluctuations.
- Observe the operating instructions for the connected devices!

Clothes hook

 **Read and observe**  on page 80 first.

The clothes hooks are located on the handle of the headliner above each of the rear doors.

WARNING

- Ensure that any clothes hanging from the hooks do not impair your vision to the rear.
- Only use the hooks for hanging light items of clothing and ensure that there are no heavy or sharp-edged objects in the pockets.
- Do not use clothes hangers for hanging up items of clothing otherwise this may reduce the effectiveness of head airbags.

CAUTION

The maximum permissible load of the hooks is 2 kg.

Car park ticket holder

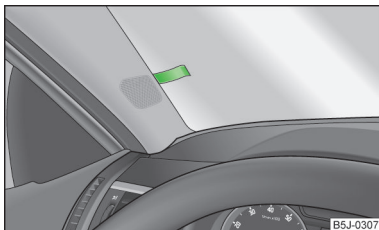

Fig. 80
Windscreen: Parking ticket holder

 **Read and observe**  on page 80 first.

The note holder is designed e.g. for attaching car park tickets.

WARNING

The attached note has to always be **removed** before starting off in order not to restrict the driver's vision.

Storage compartments

Introduction

This chapter contains information on the following subjects:

Storage compartment on the front passenger side	84
Cooling the storage compartment on the front passenger side	84
Storage compartment on the driver's side	84
storage pockets on the front seats	84
sunglasses compartment	85
Storage compartment in the front centre console	85
storage compartment under the front seat	85
Front armrest with storage compartment	86
folding table in the middle back seat	86
slots in the doors	86
stowage compartments in the luggage	87
Flexible storage compartment	87

WARNING

- Do not place anything on the dash panel. These objects might slide or fall down while you are driving (under acceleration or when cornering) and could distract you from the traffic - there is a risk of an accident.
- Make sure that no objects from the centre console or from other storage compartments can get into the driver's footwell while you are driving. You would then no longer be able to apply the brakes or operate the clutch or accelerator pedal - there is a risk of an accident.

Storage compartment on the front passenger side

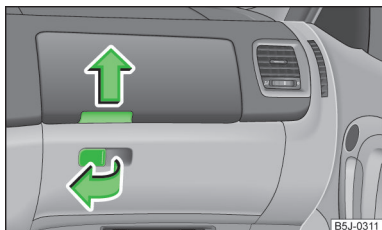

Fig. 81
Dash panel: Storage compartments on the front passenger side

Read and observe **!** on page 83 first.

Open/close

- Pull the cover handle in the direction of the arrow » Fig. 81 and fold down the cover.
- Lift the lid upwards until it clicks into place.

A pin holder is located inside the lower flap.

! WARNING

The storage compartments must always be closed when driving for safety reasons.

Cooling the storage compartment on the front passenger side

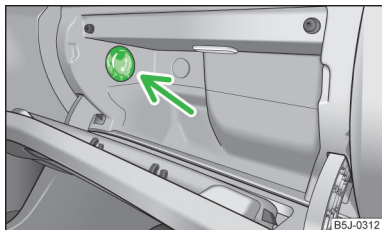

Fig. 82
Storage compartment: Using cooling system

Read and observe **!** on page 83 first.

- Use the rotary switch » Fig. 82 to open and close the air supply.

Opening the air supply when the air conditioning system is switched on allows cooled air to flow into the storage compartment.

Opening the air inlet when the air conditioning system is on causes fresh or interior air to flow into the storage compartment.

We recommend closing the air supply if it is operated in heating mode or the cooling system for the storage compartment is not being used.

Storage compartment on the driver's side



Fig. 83
Dash panel: Storage compartment on the driver's side

Read and observe **!** on page 83 first.

The open storage compartment below the light switch » Fig. 83.

storage pockets on the front seats



Fig. 84
Front seat rests: Map pockets

Read and observe **!** on page 83 first.

Map pockets are located on the rear of the seat backrests » Fig. 84.

The map pockets are intended for storage of maps, magazines, etc. ►

! WARNING

Never put heavy items in the map pockets - risk of injury.

! CAUTION

Do not put any large items such as bottles or sharp objects into the map pockets, as the pockets and the seat covers could be damaged.

sunglasses compartment

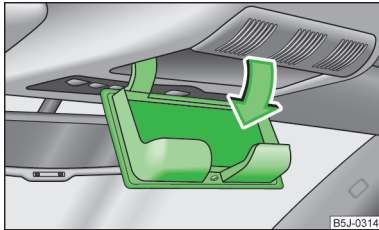

Fig. 85
Detail of the headliner: Glasses storage box

Read and observe **!** on page 83 first.

➤ Press on the bar in the cover of the glasses storage. The compartment folds down » Fig. 85.

! WARNING

The compartment must only be opened when removing or inserting the spectacles and otherwise must be kept closed.

! CAUTION

- Do not put any heat-sensitive objects in the glasses storage box - they may be damaged.
- The maximum permissible load of the glasses compartment is 250 g.

Storage compartment in the front centre console

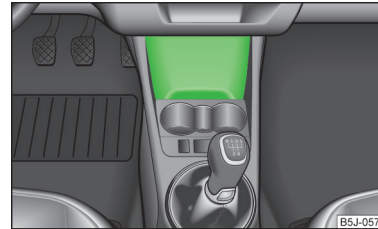

Fig. 86
Centre console: Stowage compartment

Read and observe **!** on page 83 first.

The open stowage compartment in the centre console » Fig. 86.

storage compartment under the front seat

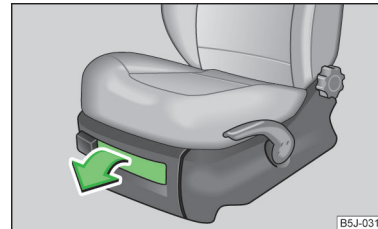

Fig. 87
Front seat: Stowage compartment

Read and observe **!** on page 83 first.

- Pull the handle to open the lid » Fig. 87.
- When closing the lid, hold the handle until the compartment is closed.

! WARNING

The storage compartment must always be closed when driving for safety reasons.

! CAUTION

The storage compartment is designed for storing small objects of up to 1 kg. in weight.

Front armrest with storage compartment

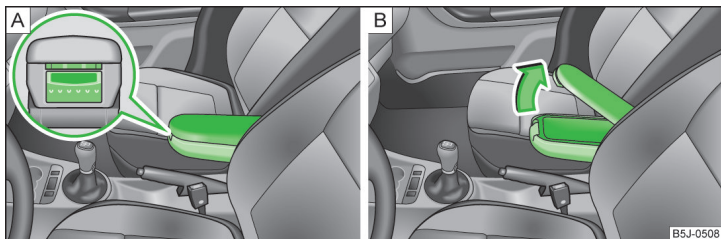

Fig. 88 Armrest: Storage compartment/open storage compartment

Read and observe **!** on page 83 first.

Fold the armrest forwards

- Press the lower button on the end of the armrest » Fig. 88 - **A**.
- Fold the arm rest forward and release the button again.

Opening the storage compartment

- Press the upper button and open the cover of the stowage compartment upwards » Fig. 88 - **B**.

i Note

The moving space of the arms can be restricted if the armrest is folded forwards. In city traffic the armrest should not be folded forwards.

folding table in the middle back seat

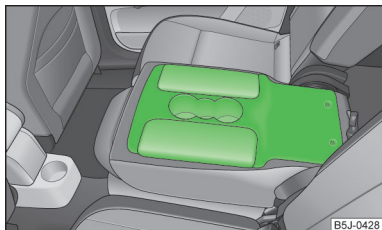

Fig. 89
Rear seats: Armrest

Read and observe **!** on page 83 first.

The centre seat back can be used as an armrest forward or table with cup holders » Fig. 89 by folding it forwards » page 71, *Fold down seat backrest and seat fold down completely* .

Two beverage containers can be placed into the recesses.

! WARNING

- Never put hot beverage containers in the cup holder. They may spill if the vehicle moves – there is a risk of scalding.
- Do not use any cups or beakers made of fragile material (e.g. glass, porcelain). This could lead to injuries in the event of an accident.

! CAUTION

- Do not leave open beverage containers in the cup holder during the journey. There is a risk of spilling e.g. when braking which may cause damage to the electrical components or seat upholstery.
- If the middle rear seat backrest should be folded forward for lengthy periods, then make sure that the belt locks are not located below it - this can warp the upholstery or fabric.

slots in the doors

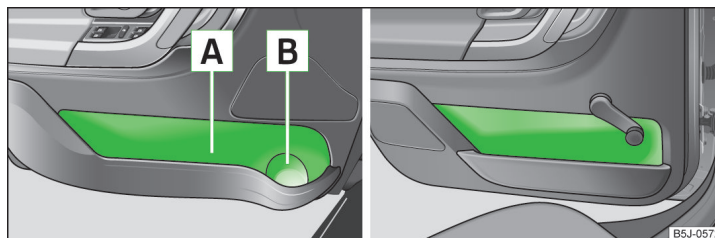

Fig. 90 Storage compartment: in the front door/in the rear door

Read and observe **!** on page 83 first.

There is a bottle holder at **B** » Fig. 90 of the pocket in the front doors. ▶

! WARNING

Use the section **A** » Fig. 90 of the door pocket only for storing objects which do not project so that the effectiveness of the side airbag is not impaired.

stowage compartments in the luggage

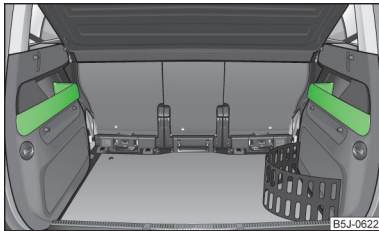

Fig. 91
Storage compartments in the side trim panel

Read and observe **!** on page 83 first.

Storage compartments are located on both sides of the luggage compartment » Fig. 91.

! CAUTION

The storage compartments are designed for storing small objects of up to 1.5 kg. in weight in total.

Flexible storage compartment

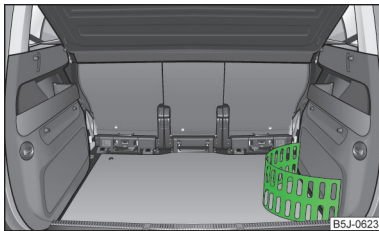

Fig. 92
Flexible storage compartment

Read and observe **!** on page 83 first.

The flexible storage compartment » Fig. 92 can be fitted to the right-hand side of the luggage compartment.

Fitting

» Insert both ends of the flexible storage compartment into the openings of the right side trim panel of the boot and push it downwards until it locks.

Removing

» Grasp the flexible storage compartment on the two upper corners.

» Press the upper corners inwards and release the storage compartment by pulling upwards.

» Remove by pulling towards you.

! CAUTION

The storage compartment is designed for storing small objects with a maximum total weight of 8 kg.

i Note

If the variable loading floor » page 76 is installed in the luggage compartment, no flexible storage compartment can be installed.

Praktik

Introduction

This chapter contains information on the following subjects:

Lashings	88
Adjustable safety partition behind the front seats	88
Attachment of the loading floor	88
Adjustment of the safety partition	88
Emergency release of the loading area door	89
Interior lighting	89

! WARNING

The load to be transported must always be secured safely so that it does not come loose when making an emergency braking or in a vehicle collision which could cause injuries to occupants.

Lashings

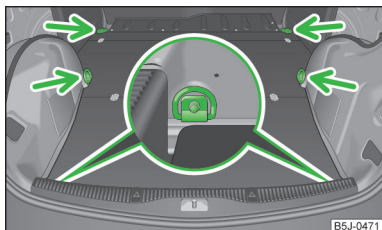

Fig. 93
Loading area: Lashing eyes

Read and observe **!** on page 87 first.

Eyes are located on the sides of the loading area for lashing down the load » Fig. 93.

Adjustable safety partition behind the front seats

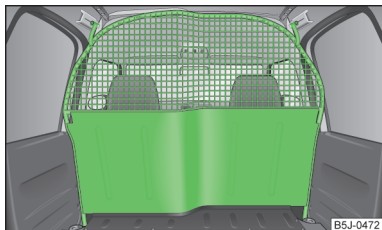

Fig. 94
Adjustable safety partition

Read and observe **!** on page 87 first.

The adjustable safety partition behind the front seats can be adjusted up to 100 mm (only valid for certain countries) for improving the comfort for the driver and the front passenger.

Attachment of the loading floor

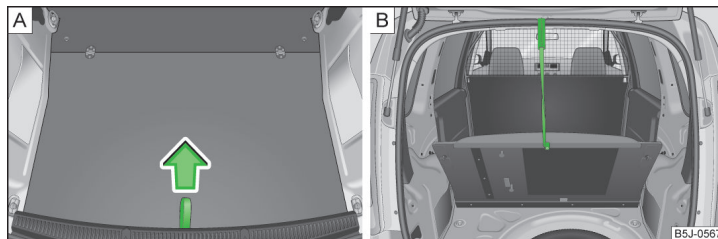

Fig. 95 Loop for raising the loading floor/Fixing the loading floor with a plastic hook

Read and observe **!** on page 87 first.

You can fix the loading floor with a hook on the top edge of the boot lid cut-out, in order to e. g. reach the spare wheel.

» Raise the loading floor by the loop » Fig. 95 - **A**) and secure it by the plastic hook (located below the loading floor edge) to the top edge of the tailgate cutout » Fig. 95 - **B**).

Adjustment of the safety partition

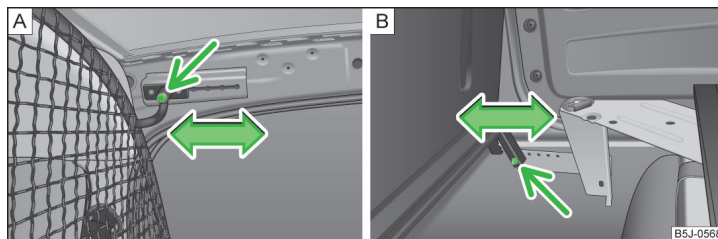

Fig. 96 Top/lower support of the safety partition

Read and observe **!** on page 87 first.

Only valid for some countries.

» Raise the loading floor part behind the safety partition.

- › Undo and remove a bolt » Fig. 96 - [A] on either side in the upper body and one bolt » Fig. 96 - [B] in the lower area.
- › Move the safety partition into the required position. Ensure it is always move the same distance- the same number of holes on both sides both upwards and downwards.
- › On each side in the upper area of the body, undo and remove a bolt and undo and remove a bolt in the lower area.
- › Have the **tightening torque** of the bolts **checked** with a torque wrench as soon as possible. The tightening torque must be 20 Nm.
- › Change the position of the cover of the luggage compartment floor behind the safety partition so that it lines up with the new position of the safety partition.
- › Fold back the loading floor part.

Emergency release of the loading area door

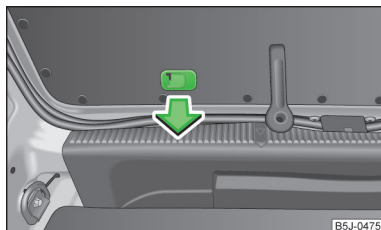

Fig. 97
Emergency unlocking of the loading area door

Read and observe **!** on page 87 first.

If there is a fault in the central locking, you can unlock the loading area door as follows:

- › Pull the control cable towards you and pull on it.
- › Press on the loading area door to open it.
- › Press the control cable back again.

Interior lighting

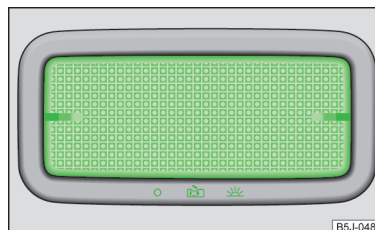

Fig. 98
Interior lighting

Read and observe **!** on page 87 first.

Switching on

- › Move the cover glass to the  position » Fig. 98.

Switching off

- › Move the cover glass to the **O** » Fig. 98 position.

Door contact setting

- › Move the cover glass to the middle position  » Fig. 98.

i Note

We recommend you have the bulb replacement performed by a specialist garage.

Heating and air-conditioning

Heating, ventilation, cooling

Introduction

This chapter contains information on the following subjects:

Air outlets	90
Using the air conditioning system economically	91
Operational problems	91

The heating effect is dependent upon the coolant temperature, thus full heat output only occurs when the engine has reached its operating temperature.

If the cooling system is switched on, the temperature and air humidity drops in the vehicle. The cooling system prevents the windows from misting up when outside temperatures are particularly low.

It is possible to briefly activate recirculated air mode to enhance the cooling effect.

Please refer to the information regarding recirculated air mode for the air-conditioning system » [page 94](#) or for Climatronic » [page 96](#).

! WARNING

- For your own safety and that of other road users, ensure that all the windows are free of ice, snow and misting. Please familiarize yourself about how to correctly operate the heating and ventilation systems, how to demist and defrost the windows, as well as with the cooling mode.
- To reduce health risks (e.g. common colds), the following instructions for the use of the cooling system are to be observed.
 - The difference between the indoor temperature and the outdoor air temperature should not be greater than about 5 ° C.
 - The cooling system is to be turned off about 10 minutes before the end of the journey.
 - Once a year, a disinfection of the air conditioner or the Climatronic is to be carried out by a specialist company.

! CAUTION

- The air inlet in front of the windscreen must be free (e.g. of ice, snow or leaves) to ensure that the heating and cooling system operates properly.
- After switching on the cooling **Condensation** from the evaporator of the air conditioning may drip down and form a puddle below the vehicle. This is not a leak.

i Note

- The exhaust air streams out through vents at the rear of the luggage compartment.
- We recommend that you do not smoke in the vehicle when the recirculating air mode is operating since the smoke which is drawn at the evaporator from the interior of the vehicle forms deposits in the evaporator of the air conditioning system. This produces a permanent odour when the air conditioning system is operating which can only be eliminated through considerable effort and expense (replacement of compressor).

Air outlets

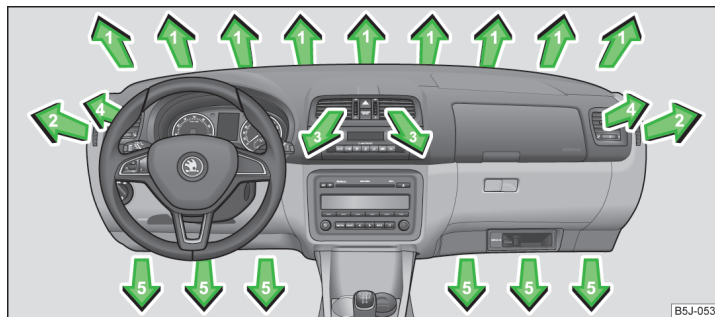



Fig. 99 Air outlet vents

📖 Read and observe **!** and **!** on page 90 first.

Warmed, not warmed fresh or cooled air will flow out of the opened air outlet vents according to the setting of the control and the outside atmospheric conditions.

The direction of airflow can be adjusted using the air outlet vents **3** and **4** » [Fig. 99](#) and the outlets can also be opened and closed individually.

Open the air outlet vents 3 and 4

► Turn the vertical wheel (air vents 3) » Fig. 99 or the horizontal wheel (air outlet nozzles 4) to the  position.

Close air outlet vents 3 and 4

► Turn the vertical wheel (air vents 3) » Fig. 99 or the horizontal wheel (air outlet nozzles 4) to the 0 position.

Change air flow of air outlet vents 3 and 4

► In order to change the strength of the air flow, swivel the horizontal lamellas with the aid of the moveable adjuster » Fig. 99.

► In order to change the lateral direction of the air flow, swivel the vertical lamellas with the aid of the moveable adjuster.

Set the air supply to the individual vents with the air distribution control  » Fig. 100 on page 91.

Note

Do not cover the air outlet vents with objects of any kind.

Using the air conditioning system economically

 Read and observe  and  on page 90 first.

The air conditioning system compressor uses power from the engine when in cooling mode, which will affect the fuel consumption.

It is recommended to open the windows or the doors of a vehicle for which the interior has been strongly heated through the effect of direct sunlight in order to allow the heated air to escape.

The cooling system should not be switched on if the windows are open.

For the sake of the environment

Pollutant emissions are also lower when fuel is being saved » page 113.

Operational problems

 Read and observe  and  on page 90 first.

If the cooling system does not operate at outside temperatures higher than +5 °C, there is a problem in the system. The reasons for this may be.

► One of the fuses has blown. Check the fuse and replace if necessary » page 175.

► The cooling system has switched off automatically for a short time because the coolant temperature of the engine is too hot » page 31.

If you are not able to resolve the operational problem yourself, or if the cooler output has reduced, switch off the cooling system and seek assistance from a specialist garage.

Heating

Introduction

This chapter contains information on the following subjects:

Operation	91
Setting	92
Recirculated air mode	92

Operation

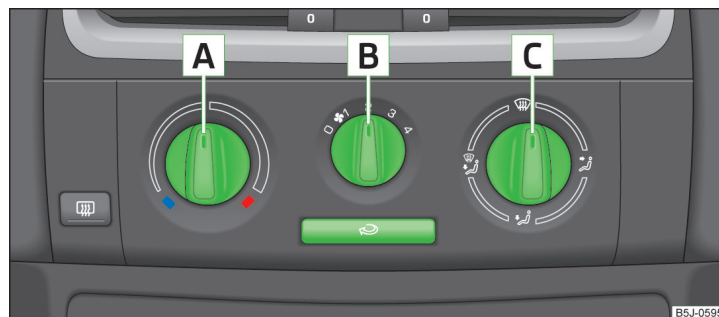

Fig. 100 Heating: Control elements

Functions of the individual operating controls » Fig. 100

- A** Set the temperature (turn to the left: to reduce the temperature, turn to the right: to increase the temperature)
- B** Set the blower level (level 0: blowers off, level 4: the highest blower speed)
- C** Set the direction of the air outlet » page 90
- ↻ Switch recirculation on/off » page 92







Controls **A** and **C** » Fig. 100 can be set to any intermediate position.

! WARNING

The blower should always be on to prevent the windows from misting up.

Setting

Recommended basic settings of the heating controls.

Set-up	Control dial settings » Fig. 100 on page 91			Symbol Key ↻ » Fig. 100 on page 91	Air outlet vents 4 » Fig. 99 on page 90
	A	B	C		
Defrosting the windshield and side windows	To the right up to the stop	3		Do not switch on	Open and align with the side window
Free windshield and side windows from mist	Desired temperature	2 or 3	 / 	Do not switch on	Open and align with the side window
The fastest heating	To the stop to the right	3		Briefly switch on	Opening
Comfortable heating	Desired temperature	2 or 3	 / 	Do not switch on	Opening
Fresh air mode - ventilation	To the stop to the left	Desired position		Do not switch on	Opening

We recommend that you leave the air outlet vents **3** » Fig. 99 on page 90 in the open position in all operating modes.

i Note

If the air distribution is set only to the windows, the entire volume of air is used to defrost the windows and thus no air will be fed to the footwell. This can limit the heating comfort.

Recirculated air mode

Recirculated air mode prevents polluted air from outside the vehicle getting in to the vehicle, for example when driving through a tunnel or when standing in a traffic jam.

Switching on/off

➤ Press the ↻ button.

The indicator light in the button lights up.

➤ Press the ↻ button again.

The indicator light in the button goes out.

Recirculated air mode is switched off automatically if the air distribution control **C** » Fig. 100 on page 91 is turned to the  position. Recirculated air mode can be switched on again from this setting by pressing the ↻ button again. ▶

! WARNING

Never leave recirculated air mode on over a longer period of time, as "stale air" can cause fatigue of the driver and the passengers, reduce attention levels and also cause the windows to mist up. The risk of having an accident increases. Switch off recirculated air mode as soon as the windows start to mist up.

Air conditioning system (manual air conditioning system)

Introduction

This chapter contains information on the following subjects:

Operation	93
Setting the air conditioning system	94
Recirculated air mode	94

The cooling system operates only if the following conditions are met.

- ✓ The cooling system is switched on » [page 93](#).
- ✓ The engine is running.
- ✓ The outside temperature is above approximately +2 °C.
- ✓ The blower switch is switched on (positions 1-4).

If the desired interior temperature can also be achieved without activating the cooling system, fresh air mode should be selected.

If the coolant temperature is too high, the cooling system is switched off to ensure that the engine cools down.

! CAUTION

- Under certain circumstances, air at a temperature of about 5 °C can flow out of the vents when the cooling system is switched on.
- Lengthy and uneven distribution of the air flow out of the vents (especially around the feet) and large differences in temperature, for example, when getting out of the vehicle, can cause susceptible individuals to catch a cold.

i Note

- We recommend that you have the air conditioning system cleaned by a specialist garage once every year.
- During operation of the air conditioning, an increase in engine idle speed may occur under certain circumstances in order to ensure sufficient heating comfort.

Operation

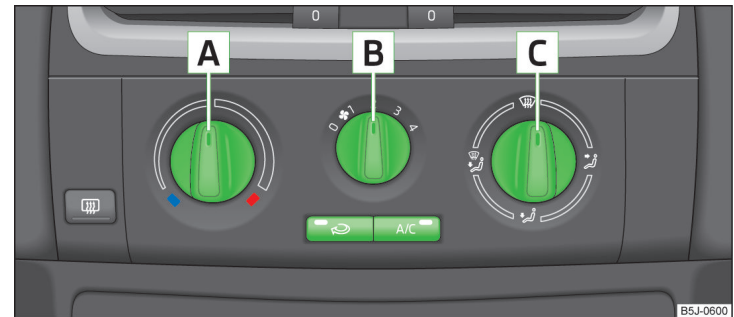

Fig. 101 The air conditioning system: Control elements

Read and observe ! on page 93 first.

Functions of the individual operating controls » [Fig. 101](#)

- A** Set the temperature (turn to the left: to reduce the temperature, turn to the right: to increase the temperature)
- B** Set the blower level (level 0: blowers off, level 4: the highest blower speed)
- C** Set the direction of the air outlet » [page 90](#)
- ↻ Switch recirculation on/off » [page 94](#)
- A/C Switch the cooling system on/off







i Note

The warning light in the symbol button **A/C** lights after activation, even if not all of the conditions for the function of the cooling system are met » [page 93](#). The operational readiness of the cooling system is indicated by the indicator light in the button lighting up.

Setting the air conditioning system

Read and observe  on page 93 first.

Recommended basic settings of the air conditioning controls.

Set-up	Control dial settings » Fig. 101 on page 93			Button » Fig. 101 on page 93		Air outlet vents 4 » Fig. 99 on page 90
	A	B	C		A/C	
Defrost/defog windscreen and side windows ^{a)}	Desired temperature	3 or 4		Do not switch on	Automatically switched on	Open and align with the side window
The fastest heating	To the stop to the right	3		Briefly switch on	Switched off	Opening
Comfortable heating	Desired temperature	2 or 3		Do not switch on	Switched off	Opening
The fastest cooling	To the left up to the stop	briefly 4, then 2 or 3		Briefly switch on ^{b)}	Activated	Opening
Optimal cooling	Desired temperature	1, 2 or 3		Do not switch on	Activated	Open and align to the roof
Fresh air mode - ventilation	To the stop to the left	Desired position		Do not switch on	Switched off	Opening

^{a)} We recommend that you do not use this setting in countries with high humidity levels. This can result in heavy cooling of the window glass and the following fogging from outside.

^{b)} Under certain conditions, recirculated air mode » page 94 may come on automatically; the warning light will then light up in the  button.

We recommend that you leave the air outlet vents 3 » Fig. 99 on page 90 in the open position in all operating modes.

Recirculated air mode

Read and observe  on page 93 first.

Recirculated air mode prevents polluted air from outside the vehicle getting into the vehicle, for example when driving through a tunnel or when standing in a traffic jam.



Switching on/off

➤ Press the  button.

The indicator light in the button lights up.

➤ Press the  button again.

The indicator light in the button goes out.

Recirculated air mode is switched off automatically if the air distribution control  » Fig. 101 on page 93 is turned to the  position.

Recirculated air mode can be switched on again from this setting by pressing the  button again.

WARNING

Never leave recirculated air mode on over a longer period of time, as "stale air" can cause fatigue of the driver and the passengers, reduce attention levels and also cause the windows to mist up. The risk of having an accident increases. Switch off recirculated air mode as soon as the windows start to mist up.

Climatronic (automatic air conditioning system)

Introduction

This chapter contains information on the following subjects:

Control elements	95
automatic mode	96
Setting the temperature	96
Recirculated air mode	96
Controlling blower	96
Defrosting windscreen	97

The Climatronic in **automatic mode** ensures the best-possible setting of the temperature of the outflowing air, the blower stage and air distribution.

The system also takes sunlight into account, which eliminates the need to alter the settings manually.

The cooling system operates only if the following conditions are met.

- ✓ The cooling system is switched on » [page 95](#).
- ✓ The engine is running.
- ✓ The outside temperature is above approximately +2 °C.
- ✓ The blower is switched on.

If the coolant temperature is too high, the cooling system is switched off to ensure that the engine cools down.

i Note

- We recommend that you have Climatronic cleaned by a specialist garage once every year.
- During operation of the Climatronic, an increase in engine idle speed can occur under certain circumstances in order to ensure adequate heating comfort.

Control elements

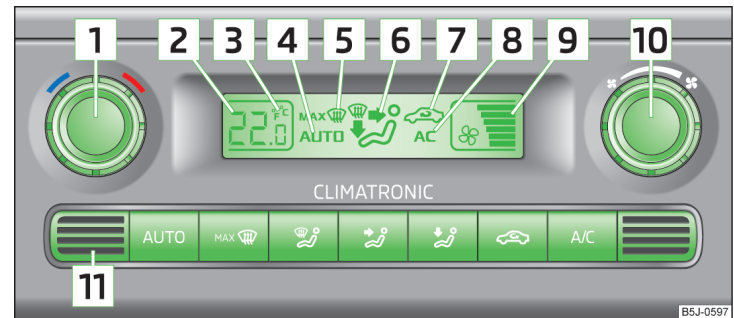

Fig. 102 Climatronic: Control elements

The buttons/control dial

- 1** Setting the interior temperature » [page 96](#)

Display

- 2** Display of selected interior temperature
- 3** Degrees Celsius or Fahrenheit, change the displayed temperature units » [page 96](#)
- 4** Automatic operation of the air conditioning system
- 5** Ventilation or defrosting of the windscreen activated
- 6** Direction of air flow
- 7** Recirculated air mode activated
- 8** Cooling system activated
- 9** Set blower speed

The buttons/control dial

- 10** Setting the blower speed » [page 96](#)

- 11** Interior temperature sensor

AUTO Automatic mode » [page 96](#)

MAX Ventilation or defrosting of the windscreen » [page 97](#)

Air flow to the windows

Air flow to the upper body

Air flow in the footwell

 Switch recirculation on/off » [page 96](#)

A/C Switch the cooling system on/off

i Note

Do not stick anything on or cover the interior temperature sensor  » [Fig. 102](#); it could have an unfavourable effect on the Climatronic system.

automatic mode

The automatic mode is used in order to maintain a constant temperature and to demist the windows in the interior of the car.

Switching on

- › Set a temperature between +18 °C and +29 °C.
- › Move the air outlet vents **3** » [Fig. 99 on page 90](#) and **4** so that the air flow is directed slightly upwards.
- › Press the **AUTO** button » [Fig. 102 on page 95](#); **AUTO** will appear in the display.

Automatic mode can be **switched off** by pressing any of the air distribution buttons or by increasing/decreasing the blower speed. The temperature is nevertheless regulated.

Setting the temperature

Setting temperature

- › Switch on the ignition.
- › Turn the control dial  » [Fig. 102 on page 95](#) to the left or to the right to increase or decrease the temperature.

Switching between Celsius and Fahrenheit

- › Press and hold the **AUTO** and **A/C** buttons simultaneously.

The information appears in the display in the desired temperature unit (no.  » [Fig. 102 on page 95](#)).

The interior temperature can be set between +18 °C and +29 °C. The interior temperature is regulated automatically within this range.

If you set the temperature below +18 °C, "LO" appears in the display.

If you set a temperature higher than +29 °C, "HI" appears in the display.

In both end positions, the Climatronic operates at maximum cooling or heating capacity. No automatic temperature control takes place during this.

! CAUTION

Lengthy and uneven distribution of the air flow out of the vents (especially around the feet) and large differences in temperature, for example, when getting out of the vehicle, can cause susceptible individuals to catch a cold.

Recirculated air mode

Recirculated air mode prevents polluted air from outside the vehicle getting in to the vehicle, for example when driving through a tunnel or when standing in a traffic jam.

Switching on

- › Press the  button » [Fig. 102 on page 95](#).

The display shows the  icon.

Switching off

- › Press the  button » [Fig. 102 on page 95](#) again.

The  icon in the display goes out.

! WARNING

Never leave recirculated air mode on over a longer period of time, as "stale air" can cause fatigue of the driver and the passengers, reduce attention levels and also cause the windows to mist up. The risk of having an accident increases. Switch off recirculated air mode as soon as the windows start to mist up.

i Note

If recirculated air mode is switched on for around 15 minutes, the symbol  will begin to flash in the display as a sign that the recirculated air mode is switched on long-term. If the recirculated air mode is not switched off, the symbol flashes for around 5 minutes.

Controlling blower

The Climatronic system controls the blower stages automatically in line with the interior temperature. However, the blower level can be manually adjusted to suit your particular needs.

- › Turn control dial  » [Fig. 102 on page 95](#) to the left or to the right to increase or decrease the blower speed.

If the blower is switched off, the Climatronic system is switched off. ▶

The blower speed set is indicated by displaying the corresponding number of segments in icon  » Fig. 102 on page 95 in the display.

WARNING

- "Stale air" may result in fatigue in the driver and occupants, reduce attention levels and also cause the windows to mist up. The risk of having an accident increases.
- Do not switch off the Climatronic system for longer than necessary.
- Switch on the Climatronic system as soon as the windows mist up.

Defrosting windscreen

Switching on

➤ Press the **MAX**  button » Fig. 102 on page 95.

Switching off

➤ Press the **MAX**  button » Fig. 102 on page 95 again or press the **AUTO** button.

More air flows out of the air outlet vents **1** and **2** » Fig. 99 on page 90. The temperature control is controlled automatically.

Communication and multimedia

Universal telephone preinstallation GSM II

Introduction

This chapter contains information on the following subjects:

Mobile phones and two-way radio systems	97
Introductory information	98
Phone Phonebook	98
Operating the phone on the multifunction steering wheel	99
Inserting the mobile phone and adapter	99
Managing telephone calls with the help of the adapter	100
Connecting the mobile phone to the hands-free system	100
Symbols in the MAXI DOT display	101
Telephone operation in the MAXI DOT display	101

Mobile phones and two-way radio systems

ŠKODA permits the operation of mobile phones and two-way radio systems with a professionally installed external aerial and a maximum transmission power of up to 10 watts.

Please consult a ŠKODA Partner for information about the possibility of installing and operating mobile phones and two-way radio systems with a transmission power of more than 10 W.

Operating mobile phones or two-way radio systems may interfere with the functionality of the electronic systems in your vehicle.

This could be for the following reasons.

- no external aerial.
- external aerial incorrectly installed.
- transmission power greater than 10 watts.

WARNING

- Concentrate fully at all times on your driving! As the driver, you are fully responsible for the operation of your vehicle.
- Only use the device in such a way that you are in full control of your vehicle in every traffic situation – there is the risk of accidents!

! WARNING (Continued)

- The national regulations for using a mobile phone in a vehicle must be observed.
- If a mobile phone or a two-way radio system is operated in a vehicle without an external aerial or an external aerial which has been installed incorrectly, this can increase the strength of the electromagnetic field inside the vehicle.
- Two-way radio systems, mobile phones or mounts must not be installed on airbag covers or within the immediate deployment range of the airbags.
- Never leave a mobile phone on a seat, on the dash panel or in another area, from which it can be thrown during a sudden braking manoeuvre, an accident or a collision - risk of injury.
- The Bluetooth® function must be switched off by a specialist workshop before the vehicle is transported by air.

i Note

- We recommend that mobile phones and two-way radio systems be installed in the a vehicle by a specialist workshop.
- Not all mobile phones that enable Bluetooth® communication are compatible with the universal telephone preinstallation GSM II. You can ask a ŠKODA Partner whether your telephone is compatible with the GSM II universal telephone fitting.
- The range of the Bluetooth® connection to the hands-free system is restricted to the vehicle interior. The range is dependent on local factors, e.g. obstacles between the devices and mutual interferences with other devices. If your mobile phone is in a jacket pocket, for example, this can lead to difficulties when establishing a connection with the hands-free-system or transferring data.

Introductory information

The universal telephone preinstallation GSM II (hands-free system) includes a convenience mode for the mobile phone via voice control, the multifunction steering wheel, the adapter, radio or the navigation system.

The universal telephone preinstallation GSM II comprises the following functions.

- Phone Phonebook » [page 98](#).
- Convenience operation of the telephone via the multifunction steering wheel » [page 99](#).

- Managing telephone calls via the adapter » [page 100](#).
- Telephone operation in the MAXI DOT display » [page 101](#).
- Voice control of the telephone » [page 102](#).
- Music playback from the telephone or other multimedia units » [page 103](#).

All communication between a mobile phone and your vehicle's hands-free system is established with the help of Bluetooth® technology. The adapter serves only for charging the telephone and for transmitting the signal to the vehicle's external aerial.

i Note

The following guidelines must be observed » [page 97](#), *Mobile phones and two-way radio systems*.

Phone Phonebook

A phone phonebook is part of the hands-free system. This phone phonebook can be used depending on the type of mobile phone.

After the first connection of the telephone, the system begins to load the phone book from the phone and the SIM card into the memory of the control unit.

Each time the telephone has established a new connection with the hands-free system, an update of the relevant phone book is performed. The updating can take a few minutes. During this time the phone book, which was stored after the last update was completed, is available. Newly stored telephone numbers are only shown after the updating has ended.

The update is interrupted if a telephone event (e.g. incoming or outgoing call, voice control dialogue) occurs during the updating procedure. After the telephone event has ended, the updating starts anew.

The internal phonebook provides 2 500 free memory locations. Each contact can contain up to 4 numbers.

If the number of contacts loaded exceeds 2 500, the phone book is not complete.

Operating the phone on the multifunction steering wheel

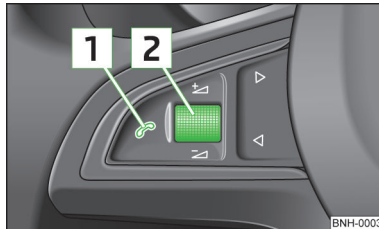

Fig. 103
Multifunction steering wheel:
Mobile phone operation

There are buttons in the steering wheel for easy operation of the basic functions of the phone » Fig. 103 so that the driver is distracted from the traffic as little as possible when using the phone.

This applies only if your vehicle has been equipped with the universal telephone preinstallation (hands-free system) at the factory.

If the side lights are switched on, the buttons and the symbols \uparrow and \downarrow on the multifunction steering wheel are illuminated.

Button/ wheel » Fig. 103	Action	Operation
1	Press briefly	Accept call, terminate call, entry in the main menu of the telephone, list of selected numbers
1	Press button for a long period of time	Reject call, last number dialled ^{a)} , switch voice control on/off ^{b)}
2	Press briefly	Switch on/off voice control
2	Turn upwards	Increase volume
2	Turn downwards	Decrease volume

^{a)} Valid for vehicles with the Amundsen+ navigation system.

^{b)} Valid for vehicles without the Amundsen+ navigation system.

Inserting the mobile phone and adapter

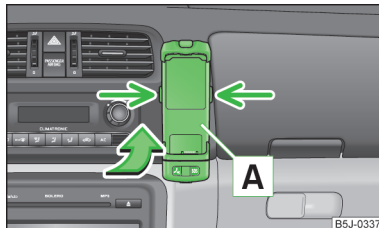

Fig. 104
Universal telephone preinstallation

Fitting

- » First of all push adapter **A** in the direction of the arrow » Fig. 104 into the mount as far as the stop. Then press the adapter slightly downwards, until it locks securely into position.
- » Insert the mobile phone into the adapter **A** (as specified in the instructions from the manufacturer of the adapter).

Removing

- » Press the side locks on the mount » Fig. 104 at the same time and remove the adapter with the mobile phone.

Only one telephone mount is factory-fitted. An adapter for the mobile phone can be purchased from ŠKODA Original Accessories.

! CAUTION

Taking the mobile phone out of the adapter during the call can lead to interruption of the connection. When removing the mobile phone, the connection to the factory-fitted antenna is interrupted, which reduces the quality of the transmitting and receiving signal. The charging of the mobile phone battery is also interrupted.

Managing telephone calls with the help of the adapter

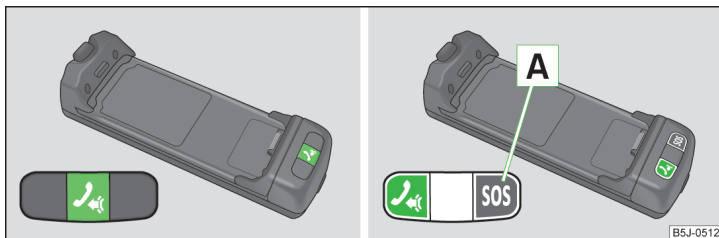





Fig. 105 Principle sketch: Adapter with one button/adapter with two buttons

Function overview of the  » Fig. 105 (PTT - "push to talk") button on the adapter.

- › Switch voice control on/off.
- › Accept/end a call.

Some adapters include the  button  » Fig. 105 in addition to the  button. After pressing this button for 2 seconds, the number 112 (Emergency call) is dialed.

Connecting the mobile phone to the hands-free system

To connect a mobile phone with the hands-free system, the two devices must be paired. Detailed information on this is provided in the operating instructions for your mobile phone.

¹⁾ Depending on the Bluetooth® version on the mobile phone, an automatically generated 6-digit PIN is either displayed or the PIN 1234 has to be entered manually.

²⁾ Some mobile phones have a menu, in which the authorisation for establishing a Bluetooth® connection is completed by inputting a code. If the authorisation input is required, it must always be performed when re-establishing the Bluetooth connection.

The following steps must be carried out for the connection.

- › Activate Bluetooth® and the visibility of your mobile phone on your telephone.
- › Switch on the ignition.
- › Select the **Phone - New user** menu in the MAXI DOT display and wait until the control unit has completed the search.
- › Select your mobile phone from the menu of the units found.
- › Confirm the PIN¹⁾.
- › If the hands-free system announces (as standard **SKODA_BT**) on the display of the mobile phone, enter the PIN¹⁾ within 30 seconds and wait, until the connection is established²⁾.
- › To finish pairing, confirm the creation of the new user profile in the MAXI DOT display.

If there is no free space available to create a new user profile, delete an existing user profile.

During the connecting procedure, no other mobile phone may be connected with the hands-free system.

Up to four mobile phones can be paired with the hands-free system, whereby only one mobile phone can communicate with the hands-free system.

The visibility of the hands-free system is automatically switched off 3 minutes after the ignition is switched on and is also deactivated when the mobile phone has connected to the hands-free system.

Restoring the visibility of the hands-free system

If you have not managed to connect your mobile phone with the hands-free system within 3 minutes of switching on the ignition, the visibility of the hands-free system can be reestablished for 3 minutes in the following ways.

- › By turning the ignition off and on.
- › By turning voice control off and on.
- › In the **Bluetooth - Visibility** menu in the MAXI DOT display. ▶

Creating a connection with an already paired mobile phone

After switching on the ignition, the connection is automatically established for the already paired mobile phone¹⁾. Check on your mobile phone if the automatic connection has been established.

Disconnecting the connection

- › By withdrawing the ignition key.
- › By disconnecting the hands-free system in the mobile phone.
- › By disconnecting the user in the **Bluetooth - Users** menu item in the MAXI DOT display.

Solving connection problems



Check the operating status of the mobile phone if the system reports **No paired phone found**.

- › Is the mobile phone switched on?
- › Is the PIN code entered?
- › Is Bluetooth[®] active?
- › Is the visibility of the mobile phone active?
- › Has the mobile phone already been paired with the hands-free system?

i Note

- If a suitable adapter is available for your mobile phone, only use your mobile phone in the adapter inserted in the telephone mount so that the radiation in the vehicle drops to a minimum.
- Placing the mobile phone in the adapter inserted in the telephone mount ensures optimum sending and receiving power.



Symbols in the MAXI DOT display

Symbol	Meaning
	Charge status of the telephone battery ^{a)}
	Signal strength ^{a)}
	a phone is connected to the hands-free system.

¹⁾ Some mobile phones have a menu, in which the authorisation for establishing a Bluetooth[®] connection is completed by inputting a code. If the authorisation input is required, it must always be performed when re-establishing the Bluetooth connection.

²⁾ On vehicles fitted with the Amundsen+ navigation system, this function can be accessed via the navigation system menu; refer to the » *Operating instructions for the Amundsen+ navigation system*.

³⁾ This function is not available in vehicles fitted with the Amundsen+ navigation system.

Symbol	Meaning
	The hands-free system is visible to other devices.
	A multimedia unit is connected to the hands-free system.

^{a)} This function is only supported by some mobile phones.

Telephone operation in the MAXI DOT display

The following menu items can be selected from the **Phone** menu.

- **Phone book**
- **Dial number**²⁾
- **Call list**
- **Voice mailbox**
- **Bluetooth**²⁾
- **Settings**³⁾
- **Back**

Phone book

The **Phone book** menu item lists the contacts downloaded from the telephone memory and the mobile phone SIM card.

Dial number

Any telephone number can be entered in the **Dial number** menu item. The required numbers must be selected one after the other using adjustment wheel and confirmed by pressing the adjustment wheel. You can select digits **0-9**, symbols **+**, *****, **#** and the **Cancel**, **Call** and **Delete** functions.

Call list

The following menu items can be selected in the **Call list** menu item.

- **Missed calls**
- **Dialled numbers**
- **Received calls**

Voice mailbox

In the **Voice mailbox** menu item, you can set the number of the voice mailbox²⁾ and then dial the number. ▶

Bluetooth

The following menu items can be selected from the **Bluetooth** menu item.

- **User** - Overview of the stored users
- **New user** - Search for new mobile phones in reception range
- **Visibility** - Switches on the visibility of the phone for other devices
- **Media Player**
 - **Active device**
 - **Paired devices**
 - **Find**
- **Phone name** - option to change the name of the phone (default SKODA_BT)

Settings

The following menu items can be selected from the **Settings** menu item.

- **Phone book**
 - **Update**¹⁾
 - **List**
 - **Surname**
 - **Name**
- **Ring tone**

Back

Return in the Start menu of the telephone.

Voice control

Introduction

This chapter contains information on the following subjects:

Dialogue	102
Voice commands	103

Dialogue

The period of time during which the system is ready to receive voice commands and to carry them out is called a dialogue. The system gives audible feedback and guides you if necessary through the relevant functions.

¹⁾ On vehicles fitted with the Amundsen+ navigation system, this function can be accessed via the navigation system menu; refer to the » *Operating instructions for the Amundsen+ navigation system*.

Optimum understanding of the voice commands depends on several factors.

- Speak with a normal tone of voice without intonation and excessive pauses.
- Avoid a bad pronunciation.
- Close the doors, windows and sliding roof, to reduce or stop disturbing exterior noise.
- It is recommended to speak louder at higher speeds, so that the tone of your voice is louder than the increased surrounding noise.
- During the dialogue, limit additional noise in the vehicle, e.g. passengers talking at the same time.
- Do not speak, if the system makes an announcement.

The microphone for voice control is inserted in the moulded headliner and directed to the driver and front passenger. Therefore the driver and the front passenger can operate the equipment.

Entering a phone number

The telephone number can be entered as a continuous series of individually spoken digits (the whole number at once) or in the form of digital blocks (separated by short pauses). After each order of digits (separation through brief voice pause) all of the digits detected up to now are repeated by the system.

The digits **0 - 9**, symbols **+**, *****, **#** are permitted. The system detects no continuous digit combinations such as twenty-three, but only individually spoken digits (two, three).

Switching on voice control

- Press the  button on the adapter » [Fig. 105 on page 100](#) briefly.
- Press the **1** button on the multifunction steering wheel briefly » [page 99](#), *Operating the phone on the multifunction steering wheel*.

Switching off voice control

If the system is currently playing a message, the message that is currently being played will have to be stopped as follows:

- Press the  button on the adapter briefly.
- Press the **1** button on the multifunction steering wheel briefly.

If the system is expecting a voice command, you can end the dialogue yourself as follows.

- With the **CANCEL** voice command.
- Press the  button on the adapter.
- Press the **1** button on the multifunction steering wheel briefly. ▶

i Note

- The dialogue of an incoming call is immediately interrupted.
- The voice control is only possible in vehicles fitted with a multifunction steering wheel with telephone control or a phone mount and adapter.

Voice commands

Basic voice commands

Voice command	Action
HELP	After this command the system repeats all possible commands.
CALL XYZ	This command calls up the contact from the phone book.
PHONE BOOK	After this command, for example, the phone book can be repeated back to you, a voice entry for the contact can be updated or deleted, etc.
CALL HISTORY	Lists of dialled numbers, missed calls, etc.
DIAL NUMBER	After this command, a telephone number can be entered to establish a connection with the requested party.
REDIAL	After this command the system calls the last dialled number.
MUSIC ^{a)}	Play music from the mobile phone or another paired device.
FURTHER OPTIONS	After this command the system offers additional context-dependent commands.
SETTINGS	Selection for setting Bluetooth [®] , dialogue etc.
CANCEL	The dialogue is ended.

^{a)} On vehicles fitted with the Amundsen+ navigation system, this function can be accessed via the navigation system menu; refer to the » *Operating instructions for the Amundsen+ navigation system*.

If a voice command is not detected, the system answers with "Sorry?", and a new entry can be made. After the 2nd error the system repeats the aid. After the 3rd attempt the answer "Cancelled" is given and the dialogue is ended.

Store voice recording of a contact

If automatic name recognition does not work reliably for some contacts, you can choose to save your own voice tag for the contact in the **Phone book - Voice tag - Record** menu item.

Your own voice tag can also be saved using the voice control in the **FURTHER OPTIONS** menu.

Multimedia

Introduction

This chapter contains information on the following subjects:

Music playback via Bluetooth [®]	103
Operating the radio and navigation system on the multifunction steering wheel	104
AUX and MDI inputs	104

Music playback via Bluetooth[®]

The universal telephone preinstallation GSM II makes it possible to play back music via Bluetooth[®] from the devices such as MP3 player, mobile phone or notebook.

To ensure the music can be played back via Bluetooth[®], you must first pair the device with the hands-free system in the **Phone - Bluetooth - Media player** menu.

The music playback process is performed on the connected device.

The universal telephone preinstallation GSM II ensures that the music played back via the hands-free system can be controlled with the remote control » [page 103](#), *Voice commands*.

i Note

The device being connected must support the Bluetooth[®] A2DP profile; refer to the operating instructions for the relevant device being connected.

Operating the radio and navigation system on the multifunction steering wheel

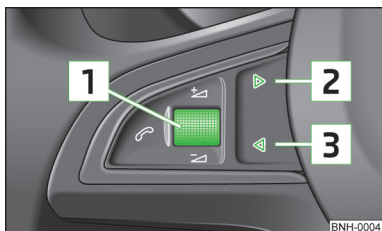

Fig. 106
Multifunction steering wheel:
control buttons

The radio and navigation system can of course still be operated on the devices. A description is included in the relevant operating instructions.

If the side lights are switched on, the buttons on the multifunction steering wheel are illuminated.

The buttons apply for the respective operating mode of the current radio or navigation system.

The following functions can be completed by pressing or turning the buttons.

The multifunction steering wheel has buttons for operating the basic functions of factory-fitted radio and navigation system » Fig. 106.

Button/ wheel » Fig. 106	Action	Radio, traffic information	CD/MP3/Navigation
1	Press briefly	Switch off/on tone	
1	Press button for a long period of time	Switch the unit on/off	
1	Turn upwards	Increase volume	
1	Turn downwards	Decrease volume	
2	Press briefly	Change to the next preset radio station Interruption of the traffic report	Changing to the next title
2	Press button for a long period of time	Search forwards	Fast forward
3	Press briefly	Change to the previous preset radio station Interruption of the traffic report	Changing to the previous title
3	Press button for a long period of time	Search backwards	Fast rewind

i Note

- The functions of button 1 are different for vehicles fitted with a universal telephone preinstallation GSM II » page 99.
- The loudspeakers in the vehicle are adjusted to the power output of the radio and navigation system of 4x20*W.

AUX and MDI inputs

The AUX input is located below the front armrest and is marked with **AUX**.

The MDI input (AUX and USB) is located at the front under the storage compartment on the passenger side.

The AUX- and MDI inputs are used to connect external audio sources (e.g. iPod or MP3 player) and to play back music from these devices via the factory-fitted radio or navigation system.

For a description of use, refer to the relevant operating instructions for the radio or navigation system.

Driving

Starting-off and Driving

Starting and stopping the engine

Introduction

This chapter contains information on the following subjects:

Electronic immobilizer _____	107
Ignition lock _____	107
Engine _____	107
Switching off the engine _____	107

The engine can only be started using a correctly coded original key.

The engine running noises may louder at first be louder for a short time after starting the cold engine. This is quite normal and is not an operating problem.

WARNING

- When driving, the ignition key must always be in the position  » Fig. 107 on page 107 (ignition switched on) without the engine running. This position is indicated by the warning lights coming on. If this is not the case, this could result in unexpected locking of the steering wheel – risk of accident!
- Only pull the ignition key from the ignition lock when the vehicle has come to a complete stop (by applying the handbrake). Otherwise, the steering could be blocked – risk of accident!
- Never leave the key in the vehicle when you exit the vehicle. Unauthorized persons, such as children, for example, could lock the car, turn on the ignition or start the engine - there is a danger of injury and accidents!
- Never leave the vehicle unattended with the engine running - there is risk of accident, damage or theft!
- Never switch off the engine before the vehicle is stationary – risk of accident!

WARNING

- Never (e.g. in garages) run the engine in a closed place - there is the danger of poisoning and death!
- Do not leave any items (e.g. cleaning cloths or tools) in the engine compartment. This presents a fire hazard and the risk of engine damage.
- Never cover the engine with additional insulation material (e.g. with a cover) – risk of fire!

CAUTION

- The starter must only be operated when the engine is not running and the vehicle is at a standstill. The starter or engine can be damaged if the starter is activated when the engine is running  » Fig. 107 on page 107.
- If the engine does not start up after a second attempt, the fuse for the fuel pump may have a fault. Check the fuse and replace if necessary » page 175, or seek assistance from a specialist garage.
- Let go of the ignition key as soon as the engine starts otherwise the starter could be damaged.
- Do not tow start the engine – there is a risk of damaging the engine and the catalytic converter. The battery from another vehicle can be used as a jump-start aid » page 172, *Jump-starting*.

CAUTION

- Avoid high engine revolutions, full throttle and high engine loads before the engine has reached its operating temperature – risk of damaging the engine!
- Do not switch the engine off immediately at the end of your journey after the engine has been operated over a prolonged period at high loads but leave it to run at an idling speed for about 1 minute. This prevents any possible accumulation of heat when the engine is switched off.

For the sake of the environment

Do not warm up the engine while the vehicle is stationary. If possible, start your journey as soon as the engine has started. Through this the engine reaches its operating temperature more rapidly and the pollutant emissions are lower.

Note

After switching off the ignition, the radiator fan can intermittently continue to operate for approx. 10 minutes.

Electronic immobilizer

📖 Read and observe **!** and **!** on page 106 first.

An electronic chip is integrated in the head of the key. The immobiliser is deactivated with the aid of this chip when the key is inserted in the ignition lock. The electronic immobiliser is automatically activated when the ignition key is withdrawn from the lock.

The engine will not start if a non-authorized ignition key is used.

The MAXI DOT display shows the following:

Immobilizer active.

Ignition lock

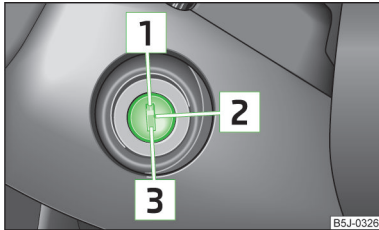

Fig. 107
Positions of the vehicle key in
the ignition lock

📖 Read and observe **!** and **!** on page 106 first.

Petrol engines » Fig. 107

- 1 Ignition switched off, engine off, the steering can be locked
- 2 Ignition switched on
- 3 Starting engine

Diesel engines » Fig. 107

- 1 Fuel supply interrupted, ignition switched off, engine switched off, the steering can be locked.
- 2 Heating glow plugs on, ignition switched on
- 3 Starting engine

To **lock the steering**, with the ignition key withdrawn, turn the steering wheel until the steering locking pin engages audibly.



If the **steering is locked** and the key cannot be turned or can only be turned with difficulty to position **2** » Fig. 107, move the steering wheel back and forth and the steering lock will unlock.

i Note

We recommend **locking the steering wheel** whenever leaving the vehicle. This acts as a deterrent against the attempted theft of your car.

Engine

📖 Read and observe **!** and **!** on page 106 first.

Vehicles with a **diesel engine** are equipped with a glow plug system. The glow plug warning light  lights up after the ignition has been switched on. Start the engine once the  warning light has gone out.

You should not switch on any major electrical components during the heating period otherwise the vehicle battery will be drained unnecessarily.

Procedure for starting the engine

- Firmly apply the handbrake.
- Move the gearshift lever into neutral or move the selector lever into position **P** or **N**.
- Switch on the ignition **2** » Fig. 107 on page 107.
- Depress and hold the clutch pedal (vehicles with a manual gearbox) or brake pedal (vehicles with an automatic gearbox) until the engine starts.
- Turn the key to position **3** to the stop and release immediately the engine has started – do not depress the accelerator.

After letting go, the vehicle key will return to position **2**.

If the engine does not start within 10 seconds, turn the key to position **1**. Repeat the start-up process after approx. half a minute.

Switching off the engine

📖 Read and observe **!** and **!** on page 106 first.

Switch off the engine by turning the ignition key to position **1** » Fig. 107 on page 107.

Introduction

This chapter contains information on the following subjects:

Information on braking	108
Handbrake	109

! WARNING

- Greater physical effort is required for braking when the engine is switched off - risk of accident!
- The clutch pedal must be depressed when braking on a vehicle with manual transmission, when the vehicle is in gear and at low revs. Otherwise, the function of the brake booster may be impaired - risk of accident!
- If a front spoiler, full wheel trim, etc. is mounted retrospectively, it must be ensured that the air supply to the front wheel brakes is not reduced. The front brakes may overheat, which can have a negative impact on the functioning of the braking system - there is a risk of an accident.
- When leaving the vehicle, never leave persons who might, for example, release the handbrake or take the vehicle out of gear unattended in the vehicle. The vehicle could then start to move - risk of accident!

! CAUTION

- Observe the recommendations on the new brake pads » [page 113](#).
- Never let the brakes slip with light pressure on the pedal if braking is not necessary. This causes the brakes to overheat and can also result in a longer braking distance and excessive wear.

Information on braking

📖 Read and observe **!** and **!** on page 108 first.

If the brakes are applied in full and the control unit for the braking system considers the situation to be dangerous for the following traffic, the brake light flashes automatically.

After the speed was reduced below around 10 km/h or the vehicle was stopped, the brake light stops flashing and the hazard warning light system switches on. The hazard warning light system is switched off automatically after accelerating or driving off again.

Before travelling a long distance down a steep gradient, reduce speed and shift into the next lowest gear. As a result, the braking effect of the engine will be used, reducing the load on the brakes. Any additional braking should be completed intermittently, not continuously.

Wear-and-tear

The wear of the brake pads is dependent on the operating conditions and driving style.

The brake pads wear more quickly if a lot of journeys are completed in towns and over short distances or if a very sporty style of driving is adopted.

Under these **severe conditions**, the thickness of the brake pads must also be checked by a specialist garage between services.

Wet roads or road salt

The performance of the brakes can be delayed as the brake discs and brake pads may be moist or have a coating of ice or layer of salt on them in winter. The brakes are cleaned and dried by applying the brakes several times.

Corrosion

Corrosion on the brake discs and dirt on the brake pads occur if the vehicle has been parked for a long period and if you do not make much use of the braking system. The brakes are cleaned and dried by applying the brakes several times.

Faults in the brake surface

If it is found that the braking distance has suddenly become longer and that the brake pedal can be depressed further, the brake system may be faulty.

Visit a specialist garage immediately and adjust your style of driving appropriately as you will not know the exact extent of the damage.

Low brake fluid level

An insufficient level of brake fluid may result in problems in the brake system. The level of the brake fluid is monitored electronically » [page 40](#), **!** *Brake system*.

Brake booster

The brake booster increases the pressure generated with the brake pedal. The brake booster only operates when the engine is running.

Handbrake

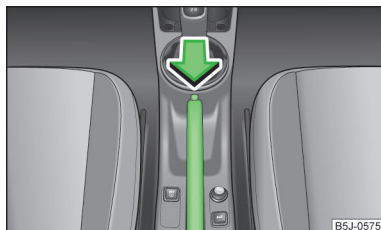

Fig. 108
Handbrake

Read and observe **!** and **!** on page 108 first.

Apply

➤ Pull the handbrake lever firmly upwards.

Releasing

➤ Pull the handbrake lever up slightly **and at the same time** push in the locking button » Fig. 108.

➤ Move the lever right down while pressing the lock button.

The handbrake warning light **!** lights up when the handbrake is applied, provided the ignition is on.

! WARNING

Please note that the handbrake must be fully released. A handbrake which is only partially released can result in the rear brakes overheating. This can have a negative effect on the operation of the brake system - there is a risk of an accident.

! CAUTION

After the vehicle has come to a standstill, always tighten the handbrake first and then switch to first gear (vehicles with manual gearbox) or move the selector lever to the P position (vehicles with automatic transmission).

Manual gear changing and pedals

Introduction

This chapter contains information on the following subjects:

Manual gear changing	109
Pedals	109

Manual gear changing

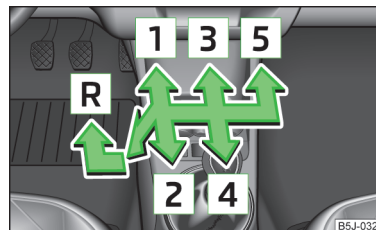

Fig. 109
Shift pattern of the 5-speed
manual gearbox

Always depress the clutch pedal all the way down. This prevents uneven wear on the clutch.

The gearshift indicator must be observed when changing gear » page 32.

Only engage reverse gear when the vehicle is stationary. Depress the clutch pedal and hold it fully depressed. Wait a moment before reverse gear is engaged to avoid any shift noises.

The reversing lights will come on once reverse gear is engaged, provided the ignition is on.

! WARNING

Never engage reverse gear when driving - risk of accident!

! CAUTION

If not in the process of changing gear, do not leave your hand on the gearshift lever while driving. The pressure from the hand can cause the gearshift mechanism to wear excessively.

Pedals

The operation of the pedals must not be hindered under any circumstances! ▶

In the driver's footwell, only a footmat, which is attached to the two corresponding attachment points, may be used.

Only use footmats from the range of ŠKODA Original Accessories, which are fitted to two attachment points.

! WARNING

No objects are allowed in the driver's footwell – risk of obstruction or limitation in operating the pedals!

Automatic transmission

Introduction

This chapter contains information on the following subjects:

Modes and use of selector lever _____	110
Manual shifting (Tiptronic) _____	111
Starting-off and driving _____	112
Malfunction _____	112
Selector lever-emergency unlocking _____	112

! WARNING

- Do not depress the accelerator if the forward driving mode is changed when the vehicle is halted and the engine is running – there is a risk of an accident.
- Never shift the selector lever to **R** or **P** modes when driving – there is a risk of an accident.
- The vehicle must be held on the brake pedal in **D**, **S** or **R** modes if the vehicle is halted and the engine is running. Even when the engine is idling, power transmission is never completely interrupted – the vehicle will creep.

! CAUTION

- If the selector lever is shifted to **N** while the vehicle is being driven you must lift off the accelerator pedal and you will need to wait until the engine has reached its idling speed before shifting the selector lever to a forward driving mode again.
- At temperatures below -10 °C, the engine can only be started in selector lever position **P**.
- Never try to hold the vehicle using the accelerator pedal when stopping on a hill – this may lead to transmission damage.

i Note

After the ignition is switched off, the ignition key can only be withdrawn if the selector lever is in position **P**¹⁾.

Modes and use of selector lever

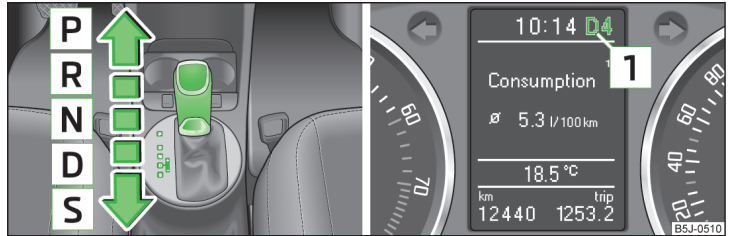

Fig. 110 Selector lever /MAXI DOT display: Selector lever positions

 Read and observe **!** and **!** on page 110 first.

When the ignition is switched on, the gearbox mode and the gear currently selected are indicated in the display **1** » Fig. 110.

The following modes can be selected with the selector lever » Fig. 110.

P - Parking mode

The driven wheels are locked mechanically in this mode.

Parking mode must only be selected when the vehicle is stationary. ▶

¹⁾ Only valid for some countries.

R - Reverse gear

Reverse gear can only be engaged when the vehicle is stationary and the engine is at idling speed.

Depress the brake pedal and simultaneously press the shiftlock in the selector lever grip before shifting to **R** from **P** or **N**.

N - Neutral

Power transmission to the drive wheels is interrupted in this mode.

D - Mode for forwards travel (normal programme)

In mode **D**, the forward gears are automatically changed according to the engine load, accelerator pedal actuation and driving speed.

S - Mode for forwards travel (sports programme)

In mode **S**, the forward gears are shifted automatically up and down at higher engine speeds than in mode **D**.

The shiftlock on the selector lever grip must be pressed when moving the selector lever out of **D** mode into **S** mode.

Releasing selector lever from **P** or **N** modes (selector lever lock)

The selector lever is locked in the **P** and **N** modes to prevent the forwards travel mode from being selected accidentally and setting the vehicle in motion.

The  warning light lights up in the instrument cluster » page 46.

The selector lever is released by depressing the brake pedal while simultaneously pressing the locking button in the selection lever grip.

The selector lever is not locked when shifted quickly through **N** (e.g. from **R** to **D**). This, for example, helps to rock out a vehicle that is stuck, e.g. in a bank of snow. The selector lever lock will engage if the lever is in position **N** for more than approximately 2 seconds without the brake pedal being depressed.

The selector lever is locked only when the vehicle is stationary and at speeds up to 5 km/h.

i Note

If you want to move the selector lever from mode **P** to mode **D** or vice versa, move the selector lever quickly. This prevents modes **R** or **N** from being selected accidentally.

Manual shifting (Tiptronic)

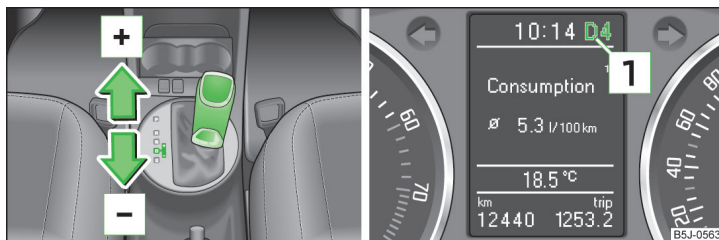

Fig. 111 Selector / MAXI DOT display: gear engaged

 Read and observe  and  on page 110 first.

Tiptronic mode makes it possible to manually shift gears on the selector lever. This mode can be selected both while halted and while driving.

The gear currently selected is indicated in the display  » Fig. 111.

The gearshift indicator must be observed when changing gear » page 32.

Switching to manual shifting

➤ Push the gear selector from position **D** towards the right, or left in a right-hand drive vehicle.

Shifting up gears

➤ Press the selector lever forwards  » Fig. 111.

Shifting down gears

➤ Press the selector lever backwards  » Fig. 111.

When accelerating, the gearbox automatically shifts up into the higher gear just before the maximum permissible engine speed is reached.

If a lower gear is selected, the gearbox does not shift down until there is no risk of the engine overrevving.

i Note

It may be beneficial, for example, when travelling downhill, to use manual shifting of gears. Shifting to a lower gear reduces the load on the brakes and hence brake wear » page 108, *Information on braking*.

Starting-off and driving

📖 Read and observe **!** and **!** on page 110 first.

Starting off

- Start the engine.
- Firmly depress and hold the brake pedal.
- Press and hold the shiftlock button on the selector lever grip.
- Move the selector lever into the desired position » [page 110](#) and then release the lock button.
- Release the brake pedal and accelerate.

Stop

- Fully depress and hold the brake pedal and bring the vehicle to a stop.
- Keep holding the brake pedal until driving is resumed.

The selector lever position **N** does not have to be selected when stopping for a short time, such as at a cross roads.

Parking

- Fully depress and hold the brake pedal and bring the vehicle to a stop.
- Firmly apply the handbrake.
- Press and hold the shiftlock button on the selector lever grip.
- Move the selector lever into the position **P** and then release the locking button.

Kickdown

The kickdown function allows you to achieve maximum acceleration by your vehicle while driving.

When the accelerator pedal is fully depressed, the kickdown function is activated in any forward driving mode.

The gearbox shifts down one or more gears depending on the vehicle speed and engine speed, and the vehicle accelerates.

The gearbox does not shift up into the highest gear until the engine has reached its maximum revolutions for this gear range.

! WARNING

Rapid acceleration, particularly on slippery roads, can lead to loss of control of the vehicle – there is a risk of an accident.

Malfunction

📖 Read and observe **!** and **!** on page 110 first.

Emergency programme

The transmission switches to the emergency programme if there is a fault in the automatic gearbox system.

Indications of an activated emergency programme include the following:

- Only certain gears are selected.
- Reverse gear **R** cannot be used.
- Shifting gears in Tiptronic mode is not possible.

Gearbox overheating

The gearbox may, for example, become too hot due to frequent repeated starting or stop-and-go traffic. Overheating is indicated by the warning light » [page 38](#),  *Clutches of the automatic DSG gearbox are too hot.*

i Note

Visit a specialist workshop if the gearbox has switched to the emergency programme.

Selector lever-emergency unlocking

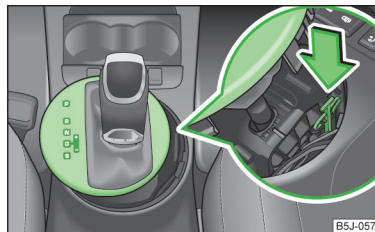

Fig. 112
Selector lever-emergency unlocking

📖 Read and observe **!** and **!** on page 110 first.

If the selector lever lock is defective or its power supply is interrupted (e.g. discharged vehicle battery, faulty fuse), the selector lever can no longer be moved out of position **P** in the normal manner, and the vehicle can no longer be driven.

The selector lever emergency unlocking procedure is as follows.

- Firmly apply the handbrake. ▶

- Carefully pull up the front left and right cover.
- Pull up rear cover.
- Use a finger to press the yellow plastic part in the direction of the arrow » Fig. 112.
- At the same time, press the locking button in the selector lever and move the selector lever to **N**.

The selector lever will be locked once more if it is moved again to **P**.

Running in

Introduction

This chapter contains information on the following subjects:

New engine	113
New tyres	113
New brake pads	113

New engine

The engine has to be run in during the first 1 500 kilometres.

Up to 1 000 kilometres

- Do not drive faster than 3/4 of the maximum speed of the gear in use, i.e. 3/4 of the maximum permissible engine speed.
- No full throttle.
- Avoid high engine speeds.
- Do not tow a trailer.

From 1 000 up to 1 500 kilometres

Gradually increase the power output of the engine up to the full speed of the gear engaged, i.e. up to the maximum permissible engine speed.

The red scale on the rev counter indicates the range in which the system begins to limit the engine speed.

During the first operating hours the engine has higher internal friction than later until all of the moving parts have harmonized. The driving style which you adopt during the first approx. 1 500 kilometres plays a decisive part in the success of running in your car.

Never drive at unnecessarily high engine speeds even after the running-in period.

On vehicles fitted with a manual gearbox, at the very latest shift up into the next gear when the red area is reached. Observe the recommended gear » page 32, *Recommended gear*. **Very** high engine speeds when accelerating (accelerator) are automatically restricted » .

In vehicles with manual transmission, do not drive at unnecessarily **low** engine speeds. Shift down a gear when the engine is no longer running smoothly. Observe the recommended gear » page 32, *Recommended gear*.

CAUTION

- The engine is not protected from excessive engine revs caused by shifting down at the wrong time. This can result in a sudden increase in revs beyond the permissible maximum rpm and hence engine damage.
- Never rev up a cold engine when the vehicle is stationary or when driving in individual gears.

For the sake of the environment

Do not drive at unnecessarily high engine speeds. Shifting up sooner helps save fuel, reduces engine noise and protects the environment.

New tyres

New tyres must firstly be "run in" since they do not offer optimal grip at first. Therefore, drive especially carefully for the first 500 km or so.

New brake pads

New brake pads do not initially provide optimal braking performance. They first need to be "run in". Therefore, drive especially carefully for the first 200 km or so.

Economical driving and environmental sustainability

Introduction

This chapter contains information on the following subjects:

Looking ahead	114
Economical gear changing.	114
Avoiding full throttle	115
Reducing idling	115
Avoiding short distances	115
Checking tyre pressure	115 ▶

Avoiding unnecessary ballast _____	115
Regular maintenance _____	116
Saving electrical energy _____	116
Environmental compatibility _____	116

The technical requirements for low fuel usage and economic efficiency of the vehicle have already been built into the vehicle at the works. ŠKODA places a particular emphasis on minimising negative effects on the environment.

It is necessary to take note of the guidelines given in this chapter in order to make best use of these characteristics and to maintain their effectiveness.

Fuel consumption, environmental pollution and the wear to the engine, brakes and tyres depend essentially on the following three factors.

- Your personal driving style
- Operating conditions
- Technical requirements

The fuel economy can be improved by 10 -15 % by always looking ahead and driving in an economical way.

Fuel consumption is also influenced by external factors which are beyond the driver's control. Consumption increases during the winter or under difficult conditions, on poor roads, etc.

Fuel consumption can vary considerably from the manufacturer's data, as a result of outside temperatures, the weather and driving style.

The optimal engine speed should be maintained when accelerating, to avoid a high fuel consumption and resonance of the vehicle.

! CAUTION

All the speed and engine revolution figures apply only when the engine is at its normal operating temperature.

Looking ahead

📖 **Read and observe !** on page 114 first.

A vehicle's highest fuel consumption occurs when accelerating, therefore unnecessary accelerating and braking should be avoided. If looking ahead when driving, less braking and consequently less accelerating are required.

If possible, let your vehicle coast to a stop, or use the engine brake, if you can see that the next set of traffic lights is on red, for example.

Economical gear changing.

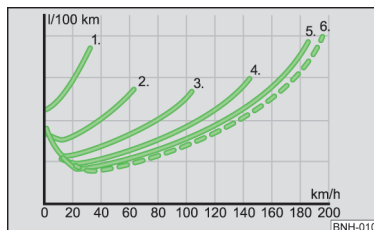

Fig. 113
Principle sketch: Fuel consumption in litres/100 km depending on the selected gear

📖 **Read and observe !** on page 114 first.

Shifting up early saves on fuel.

Manual gearbox

- Drive no more than about one length of your vehicle in first gear.
- Shift up into the next gear at approximately 2000 rpm.

An effective way of achieving good fuel economy is to shift up **early**. Observe the recommended gear » [page 32, Recommended gear](#).

A suitably selected gear can have an effect on fuel consumption » [Fig. 113](#).

Automatic gearbox

- **Slowly** apply the accelerator pedal. However, do not depress it as far as the kickdown position » [page 112](#).
- An economic driving programme is automatically selected if the accelerator pedal is only depressed slowly.

Avoiding full throttle

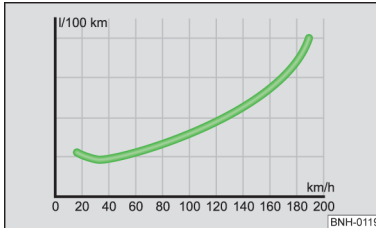

Fig. 114
Principle sketch: Fuel consumption in litres/100 km. and speed in km/h.

Read and observe  on page 114 first.

Driving more slowly saves fuel.

Sensitive use of the accelerator will not only significantly reduce fuel consumption but also positively influence environmental pollution and wear of your vehicle.

The maximum speed of your vehicle should, as far possible, never be used. Fuel consumption, pollutant emissions and vehicle noises increase disproportionately at high speeds.

The graph » Fig. 114 shows the ratio of fuel consumption to the speed of your vehicle. Fuel consumption will be halved if you drive at only three-quarters of the possible top speed of your vehicle.

Reducing idling

Read and observe  on page 114 first.

Idling also costs fuel.

In vehicles not equipped with the START-STOP system, turn off the engine when in a traffic jam, at a level crossing or traffic lights with longer wait times.

Even after just 30 - 40 seconds you will have saved more fuel than that is needed when you start the engine up again.

If an engine is only idling it takes much longer for it to reach its normal operating temperature. Wear-and-tear and pollutant emissions, though, are particularly high in the warming-up phase. Therefore, start driving as soon as the engine has started. In this case high engine speeds should be avoided.

Avoiding short distances

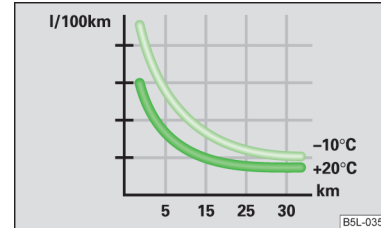

Fig. 115
Principle sketch: Fuel consumption in l/100 km at different temperatures

Read and observe  on page 114 first.

Short distances result in an above-average high fuel consumption. We therefore recommend avoiding distances of less than 4 km if the engine is cold.

A cold engine consumes the most fuel immediately after the start. Fuel consumption drops to 10 litres/100 km after just 1 kilometre. The consumption stabilises once the engine and catalytic converter have reached their operating temperature.

An important factor in this connection is also the **ambient temperature**. The graph » Fig. 115 shows the different levels of fuel consumption after driving a certain distance at a temperature of +20 °C and a temperature of -10 °C.

Checking tyre pressure

Read and observe  on page 114 first.

Tyres which are correctly inflated save fuel.

Always ensure the tyre inflation pressure is correct » page 157. If the pressure is too low, the tyres will have to overcome a higher rolling resistance. This will not only increase fuel consumption but also tyre wear and the driving behaviour will worsen.

Always check the tyre inflation pressure when the tyres are **cold**.

Avoiding unnecessary ballast

Read and observe  on page 114 first.

Transporting ballast costs fuel.

Each kilogramme of **weight** increases the fuel consumption. Therefore we recommend to carry no unnecessary weight.

It is particularly in town traffic, when one is accelerating quite often, that the vehicle weight will have a significant effect upon the fuel consumption. A rule of thumb here is that an increase in weight of 100 kilograms will cause an increase in fuel consumption of about 1 litre/100 kilometres.

At a speed of 100 - 120 km/h, a vehicle fitted with a roof rack cross member without a load will use about 10 % more fuel than normal due to the increased aerodynamic drag.

Regular maintenance

 **Read and observe**  on page 114 first.

A poorly tuned engine uses an unnecessarily high amount of fuel.

By having your vehicle regularly maintained by a specialist garage, you create the conditions needed for economical driving. The maintenance state of your vehicle has a positive effect on traffic safety and value retention

A poorly tuned engine can result in a fuel consumption which is 10 % higher than normal.

Check the **oil level** at regular intervals, e.g. when filling up. **Oil consumption** is dependent to a considerable extent on the load and speed of the engine. Oil consumption could be as high as 0.5 litres/1 000 km depending on your style of driving.

It is quite normal that a new engine has a higher oil consumption at first, and reaches its lowest level only after a certain running in time. The oil consumption of a new vehicle can therefore only be correctly assessed after driving about 5 000 km.

For the sake of the environment

- Additional improvements to the fuel economy can be made by using synthetic high-lubricity oils.
- Regularly check the ground under the vehicle. Have your vehicle inspected by a specialist garage if you find any stains caused by oil or other fluids on the ground.

Note

We recommend that your vehicle be serviced on a regular basis by a ŠKODA service partner.

Saving electrical energy

 **Read and observe**  on page 114 first.

When the engine is running, the alternator generates and supplies electrical power. If more electrical components of the electrical system are switched on, more fuel is needed to operate the alternator. We therefore recommend switching off electrical components if these are no longer required.

Environmental compatibility

 **Read and observe**  on page 114 first.

Environmental protection has played a major role in the design, material selection and production of your new ŠKODA. Particular emphasis has been placed on the following points.

Design measures

- › Joints designed to be easily detached.
- › Simplified disassembly due to the modular structure system.
- › Improved purity of different classes of materials.
- › Identification of all plastic parts in accordance with VDA Recommendation 260.
- › Reduced fuel consumption and exhaust emission CO₂.
- › Minimum fuel leakage during accidents.
- › Reduced noise.

Choice of materials

- › Extensive use of recyclable material.
- › Air conditioning filled with CFC-free refrigerant.
- › No cadmium.
- › No asbestos.
- › Reduction in the "vaporisation" of plastics.

Manufacture

- › Solvent-free cavity protection.
- › Solvent-free protection of the vehicle for transportation from the production plant to the customer.
- › The use of solvent-free adhesives.
- › No CFCs used in the production process.
- › Without use of mercury.
- › Use of water-soluble paints.

Trade-in and recycling of old cars

ŠKODA meets the requirements of the brand and its products with regard to protecting the environment and the preserving resources. All new ŠKODA vehicles can be recycled by up to 95 % and can always¹⁾ be returned free of charge.

In a lot of countries sufficient trade-in networks have been created, where you can trade-in your vehicle. After you trade-in your vehicle, you will receive a confirmation stating the recycling in accordance with environmental regulations.

i Note

You can find more detailed information about the trade-in and recycling of old cars from a specialist garage.

Avoiding damage to your vehicle

Introduction

This chapter contains information on the following subjects:

General information	117
Driving through water on streets	117

General information

Pay attention to low-slung parts of the vehicle, such as the spoiler and exhaust, particularly in the following situations.

- When driving on poorly maintained roads and paths.
- When driving over kerbs.
- When driving on steep ramps, etc.

Particular attention is required for vehicles with sport suspension and when the vehicle is fully laden.

¹⁾ Subject to fulfilment of the national legal requirements.

Driving through water on streets

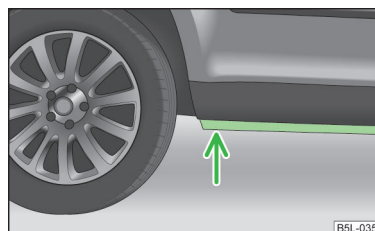

Fig. 116
Maximum permissible water level when driving through water

The following instructions must be observed if vehicle damage is to be avoided when driving through water (e.g. flooded roads).

- Determine the depth of the water before driving through it.

The water level must not reach above the web of the lower beam » Fig. 116.

- Do not drive any faster than at a walking speed.

At a higher speed, a water wave can form in front of the vehicle, which can cause water to penetrate into the engine's air intake system or other parts of the vehicle.

- Never stop in the water, do not reverse and do not switch the engine off.

! WARNING

- Driving through water, mud, sludge etc. can impair the braking power and extend the braking distance - risk of accident!
- Avoid abrupt and sudden braking immediately after water crossings.
- After driving through bodies of water, the brakes must be cleaned and dried as soon as possible by intermittent braking. Only apply the brakes for the purpose of drying and cleaning the brake discs if the traffic conditions permit this. Do not place any other road users in jeopardy.

! CAUTION

- Should water penetrate into the intake system of the engine, there is a threat of serious damage being incurred by the engine parts!
- When driving through water, some vehicle parts such as chassis, electrics or transmissions can be severely damaged.

- Oncoming vehicles can generate water waves which can exceed the permissible water level for your vehicle.
- Potholes, mud or rocks can be hidden under the water, making it difficult or impossible to drive through water.
- Do not drive through salt water, as the salt can cause corrosion. A vehicle coming into contact with salt water is to be thoroughly rinsed with fresh water.

i Note

After driving through water, we recommend having the vehicle checked by a specialist garage.

Driving abroad

Introduction

This chapter contains information on the following subjects:

Unleaded petrol _____	118
Headlights _____	118

In certain countries, it may be possible that the ŠKODA service partner network is limited or has not been established. This is the reason why procuring certain spare parts may be somewhat complicated and specialist garages may only be able to make limited repairs.

Unleaded petrol

A vehicle fitted with a petrol engine must always be refuelled with unleaded petrol » [page 143](#), *Unleaded petrol*. Information regarding the locations of filling stations that offer unleaded petrol is, for example, provided by the automobile associations.

Headlights

The low beam of your headlights is set asymmetrically. It illuminates the side of the road on which the vehicle is being driven to a greater extent.

When driving in countries in which the traffic drives on the other side of the road than in your home country, the asymmetrical low beam may dazzle oncoming drivers. In order to avoid this, the headlights must be adjusted at a specialist garage.

i Note

You can find out more information on adjusting the headlights at a specialist garage.

Assist systems

Brake assist systems

Introduction

This chapter contains information on the following subjects:

Electronic Stability Control (ESC)	119
Antilock Braking System (ABS)	120
Traction Control System (ASR)	120
Electronic Differential Lock (EDL)	120

! WARNING

- A lack of fuel can cause irregular engine running or cause the engine to shut down. The brake assist systems would then fail to function - risk of accident!
- Adjust the speed and driving style to the current visibility, weather, road and traffic conditions. The increased safety provided by the brake assist systems must not tempt you to take safety risks - risk of accident!
- In the event of an ABS fault, visit a specialist garage immediately. Adjust your style of driving according to the damage to the ABS, as you will not know the exact extent of the damage or the extent to which this is limiting the braking efficiency.

! CAUTION

- All four wheels must be fitted with the same tyres approved by the manufacturer to ensure the brake assist systems operate correctly.
- Changes to the vehicle (e.g. to the engine, brakes, chassis) can influence the functionality of the brake assist systems » [page 132](#), *Services, modifications and technical alterations*.
- If a fault occurs in the ABS system, the ESC, TCS and EDL will also fail to work. An ABS fault is indicated with the warning light  » [page 42](#).

Electronic Stability Control (ESC)

 **Read and observe**  and  on [page 119](#) first.

The ESC system helps to maintain control of the vehicle in situations where it is being operated at its dynamic limits, such as a sudden change in the direction of travel. Depending on the road surface conditions, the risk of skidding is reduced, thereby improving the vehicle's driving stability .



The ESC system is automatically activated each time the ignition is switched on.

The direction which the driver wishes to take is determined based on the steering angle and the speed of the vehicle and is constantly compared with the actual behaviour of the vehicle. In the event of deviations occurring, such as the car beginning to skid, the ESC system will automatically brake the appropriate wheel.

During an intervention of the system, the warning light  flashes in the instrument cluster.

The following systems are integrated into the **electronic stabilisation control (ESC)**:

- Antilock brake system (ABS),
- Traction control (TCS),
- Electronic Differential Lock (EDL)
- Hydraulic Brake Assist (HBA)
- Hill Hold Control (HHC).

The ESC system cannot be deactivated. The  » [Fig. 117 on page 120](#) button can only be used to deactivate the TCS. The  warning light comes on in the instrument cluster when the TCS is deactivated.

In the event of an ESC fault, the ESC warning light illuminates in the instrument cluster  » [page 42](#).

Hydraulic Brake Assist (HBA)

HBA increases the braking effect and helps to shorten the braking distance.

The HBA is activated by very quick operation of the brake pedal. In order to achieve the shortest possible braking distance, the brake pedal must be applied firmly until the vehicle has come to a standstill.

The HBA function is automatically switched off when the brake pedal is released.

The ABS is activated faster and more effectively with the intervention of the HBA.

Hill Hold Control (HHC)

When driving on slopes, HHC allows you to move your foot from the brake pedal to the accelerator pedal without having to use the handbrake.

The system holds the brake pressure produced by the activation of the brake pedal for approx. 2 seconds after the brake pedal is released. ▶

The brake pressure drops gradually the more you operate the accelerator pedal. If the vehicle does not start off within 2 seconds, it starts to roll back.

HHC is active on slopes of >5 % when the driver door is closed. HHC is always only active on slopes when in forward or reverse start off. When driving downhill, it is inactive.

Antilock Braking System (ABS)

Read and observe and on page 119 first.

ABS prevents the wheels locking when braking. Thus helping the driver to maintain control of the vehicle.

The intervention of the ABS is noticeable from the **pulsating movements of the brake pedal** which is accompanied by noises.

When the ABS system is active, do not brake periodically or reduce the pressure on the brake pedal.

Traction Control System (ASR)



Fig. 117
TCS button

Read and observe and on page 119 first.

If the wheels are slipping, the ASR system adapts the engine speed to the conditions of the road surface. The TCS makes it much easier to start off, accelerate and climb steep hills even if the conditions of the road surface are unfavourable.

The TCS function is automatically activated each time the ignition is switched on.

During an intervention of the system, the TCS warning light flashes in the instrument cluster.

The TCS should normally always be enabled. Only in certain exceptional circumstances can it be sensible to switch the system off, for instance:

- when driving with snow chains;
- when driving in deep snow or on a very loose surface;
- when it is necessary to "rock a vehicle free" when it has got stuck.

Ensure the TCS is activated again afterwards.

You can switch TCS off and on again as needed by pressing the button » Fig. 117. The warning light comes on in the instrument cluster when the TCS is deactivated.

The TCS warning light » page 45 lights up in the instrument cluster when there is a fault on the TCS.

Electronic Differential Lock (EDL)

Read and observe and on page 119 first.

If one of the wheels starts to spin, the EDL system brakes the spinning wheel and transfers the driving force to the other wheels. This ensures the stability of the vehicle and a quick journey.

EDL switches off automatically to avoid excessive heat generation on the brake of the wheel being braked. The vehicle can continue to be driven and has the same characteristics as a vehicle not fitted with EDL. The EDL switches on again automatically as soon as the brake has cooled down.

Parking aid

Introduction

This chapter contains information on the following subjects:

Function	_____	121
Activation/deactivation	_____	121▶

! WARNING

- The parking aid is not a substitute for the driver paying proper attention and it is always the driver's responsibility to take care when reversing the vehicle or carrying out similar manoeuvres. Pay particular attention to small children and animals as they are not recognised by the parking aid sensors.
- Before reversing, you should make sure that there are no small obstacles, such as rocks, thin posts, trailer drawbars etc. behind your vehicle. Such obstacles may not be recognised by the parking aid sensors.
- Under certain circumstances, surfaces of certain objects and types of clothing cannot reflect the system signals. Thus, these objects or people who wear such clothing are not recognised by the System sensors.
- External sound sources can have a detrimental effect on the system. Under adverse conditions, this may cause objects or people to not be recognised by the system.

! CAUTION

- If a warning signal sounds for about 3 seconds after activating the system and there is no obstacle close to your car, this indicates a system fault. Have the fault rectified by a specialist garage.
- The sensors must be kept clean (free of ice, etc.) to enable the parking aid to operate properly.
- Under adverse weather conditions (heavy rain, water vapour, very low or high temperatures etc.), the system function may be limited - "incorrect recognition of obstacle".
- Additionally fitted modules, such as a bicycle rack, can impair the function of the parking aid.

Function

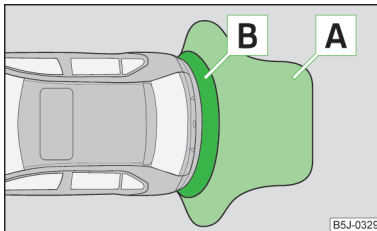

Fig. 118
Parking aid: Range of sensors

📖 Read and observe ! and ! on page 121 first.

The parking aid (referred to below solely as system) only works when the ignition is switched on.

The system supports the driver via audible signals, via the display on the radio or via the factory-installed navigation system when parking and manoeuvring » *Radio user guide, Navigation system user guide.*

The system uses ultrasound waves to calculate the distance between the bumper and an obstacle. The ultrasonic sensors are integrated in the rear bumper.

Range of sensors

The clearance warning begins at a distance of about 160 cm from the obstacle (area **A** » Fig. 118). The interval between the warning signals becomes shorter as the clearance is reduced.

A continuous tone sounds from a distance of approx. 30 cm (area **B**) - danger area. **You should not reverse any further after this signal sounds!**

On vehicles with a factory-fitted towing device, the border of the danger area starts (continuous tone) 5 cm further away from the vehicle. The length of the vehicle can be increased with an installed detachable towing device.

Activation/deactivation

📖 Read and observe ! and ! on page 121 first.

The system is activated automatically by engaging **reverse gear**. This is confirmed by a brief audible signal.

The system is deactivated by disengaging reverse gear.

i Note

The system cannot be activated on vehicles with a factory-fitted towing device when towing a trailer.

Cruise Control System

📖 Introduction

This chapter contains information on the following subjects:

Storing a speed _____ 122
Changing a stored speed _____ 122 ▶

Switching off temporarily _____	123
Switching off completely _____	123

The Cruise Control System (CCS) maintains a set speed, more than 25 km/h, without you having to actuate the accelerator pedal.

This is only possible within the range which is permitted by the power output and braking power of the engine.

The  warning light in the instrument cluster lights up when the cruise control system is switched on.

WARNING

- For safety reasons, the cruise control system must not be used in dense traffic or on unfavourable road surfaces (such as icy roads, slippery roads, loose gravel) – there is a risk of an accident.
- The saved speed may only be resumed if it is not too high for the current traffic conditions.
- Always deactivate the cruise control system after use to prevent the system being switched on unintentionally.

CAUTION

- The cruise control system is not able to maintain a constant speed when driving in areas with steeper gradients. The weight of the vehicle increases the speed at which it travels. Therefore, shift to a lower gear in good time or slow the vehicle down by applying the foot brake.
- It is not possible to switch on the cruise control system on vehicles fitted with a manual gearbox if the first gear or reverse gear is engaged.
- On vehicles fitted with an automatic gearbox, it is not possible to switch on the cruise control system if the selector lever is in position **P**, **N** or **R**.
- The Cruise Control System may automatically switch off when some brake assist systems (e.g. ESC) intervene, when the speed exceeds maximum permissible engine speed, or a similar event takes place.

Storing a speed

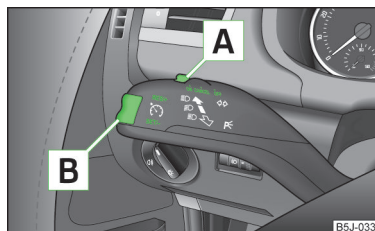

Fig. 119
Operating lever: Operating the cruise control system

 Read and observe  and  on page 122 first.

Storing a speed

- Press switch **A** » Fig. 119 to the **ON** position.
- After the desired speed has been reached, press the rocker button **B** into the **SET** position.

After you have released the rocker button **B** out of the position **SET**, the speed you have just stored is maintained at a constant speed without having to depress the accelerator.

Changing a stored speed

 Read and observe  and  on page 122 first.

Increasing the speed with the accelerator

- Depress the accelerator to increase the speed.
- Release the accelerator to reduce the speed back down to the preset speed.

However, if the saved speed is exceeded by more than 10 km/h for a period of more than 5 minutes by depressing the accelerator, the stored speed is deleted from the memory. You have to re-store the desired speed.

Increasing the speed with the rocker button **B**

- Press rocker button **B** » Fig. 119 on page 122 to the **RES** position.
- The speed will increase continuously, if the rocker button is pressed and held in the **RES** position. Release the rocker button once the desired speed is reached. The set speed is then stored in the memory.

Decreasing the speed

- The stored speed can be **reduced** by pressing rocker button **B** » Fig. 119 on page 122 to the **SET** position.

- The speed will decrease continuously, if the rocker button is pressed and held in the **SET** position. Release the rocker button once the desired speed is reached. The set speed is then stored in the memory.
- If the rocker button is released at a speed below around 25 km/h, the speed is not stored and the memory is erased. The speed must then be stored again by pressing rocker button **[B]** to the **SET** position after increasing the speed of the vehicle to more than around 25 km/h.

The speed can also be reduced by depressing the brake pedal, which temporarily deactivates the system.

Switching off temporarily

📖 Read and observe **!** and **!** on page 122 first.

The cruise control system can be temporarily switched off by pushing switch **[A]** » Fig. 119 on page 122 to the spring-loaded **CANCEL** position or by depressing the brake or clutch pedal.

The set speed remains stored in the memory.

Briefly push rocker button **[B]** to the **RES** position to resume the set speed after the clutch or brake pedal is released.

Switching off completely

📖 Read and observe **!** and **!** on page 122 first.

- Press switch **[A]** » Fig. 119 on page 122 to the right to the **OFF** position.

START-STOP

📖 Introduction

This chapter contains information on the following subjects:

Operating conditions for the system	123
Operation	124
System related automatic start-up	124
Manually deactivating/activating the system	124
Information messages	124

The **START-STOP** system (hereinafter referred to as the system) saves fuel and reduces polluting emissions and CO₂ emissions by turning the engine off, e.g. when stopping at traffic lights, and starting the engine again when moving off.

! WARNING

- Never let the vehicle roll with the engine switched off.
- The brake servo unit and power steering only operate if the engine is running.

Operating conditions for the system



Fig. 120
Maxi DOT display: Engine is automatically switched off / automatic engine cut off is not possible

📖 Read and observe **!** on page 123 first.

For system-dependent automatic engine shutdown to work, the following conditions must be met.

- ✓ The driver's door is closed.
- ✓ The driver has fastened the seat belt.
- ✓ The bonnet is closed.
- ✓ The driving speed exceeded 4 km/h after the last stop.
- ✓ No trailer is coupled.

Some additional conditions for the system to function correctly cannot be influenced or recognised by the driver. Therefore, the system can react differently in situations which are identical from the driver's perspective.

If after stopping the car, the message **START-STOP NOT POSSIBLE** appears in the segment display or the MAXI DOT display shows the  » Fig. 120 warning sign, then the conditions for automatic engine shutdown are not being met. ▶

Running the engine is essential for the following reasons, for example.

- The engine temperature for the proper function of the system has not yet been reached.
- The charge state of the vehicle battery is too low.
- The current consumption is too high.
- High air-conditioning or heating capacity (high fan speed, big difference between the desired and actual interior temperature).

i Note

- If the vehicle remains outdoors for a long time in minus temperatures or in direct sunlight, it can take several hours until the internal temperature of the vehicle battery reaches a suitable temperature for proper operation of the START STOP system.
- If the driver's seat belt is removed for more than approx. 30 seconds or the driver's door is opened during stop mode, the engine will have to be started manually.
- After the manual engine start, the automatic engine shutdown can take place only when a minimum distance required for the system function has been covered.

Operation

Read and observe **i** on page 123 first.

In compliance with the operating conditions, automatic engine shutdown / automatic engine start takes place as described.

Automatic engine shutdown

- Stop the vehicle.
- Shift the gear lever to Neutral.
- Release the clutch pedal.

Automatic engine shutdown takes place, segment display shows **START-STOP ACTIVE** or the MAXI DOT display shows the warning sign **(A)** » Fig. 120 on page 123.

Automatic engine start

- Depress the clutch pedal.

The automatic start procedure takes place again.

System related automatic start-up

Read and observe **i** on page 123 first.

When the engine is off, the system can automatically start the engine before the desired journey continues. Some possible reasons for this are:

- The vehicle has begun to roll, e.g. on a slope.
- The brake pedal has been actuated several times.
- The current consumption is too high.

Manually deactivating/activating the system



Fig. 121
Button for the START-STOP system

Read and observe **i** on page 123 first.

Deactivating/activating

- Press the **(A)** button » Fig. 121.

When start-stop mode is deactivated, the warning light in the button lights up.

i Note

If the system is deactivated when the engine is turned off automatically, then the automatic start process takes place.

Information messages

Read and observe **i** on page 123 first.

The messages and information are indicated in the instrument cluster display.

M Start the engine manually.

S START MANUALLY

One of the conditions for automatic engine start is not satisfied or the driver's seat belt is not fastened. The engine must be started manually. ▶

M Error: Start-Stop
S ERROR START-STOP

A system error is present. Seek help from a specialist garage.

Tyre pressure monitoring

Introduction

This chapter contains information on the following subjects:

Save tyre pressure values _____ 125

The tyre pressure monitoring function (hereinafter referred to only as a system) monitors the tyre pressure while driving.

If the rolling circumference of a wheel is changed, the indicator light (U) in the instrument cluster lights up and an audible signal sounds.

Information on the procedure for the notification of change of tyre inflation pressure » [page 45](#).

The system can only function properly if the tyres have the prescribed inflation pressure and this pressure values are stored in the system.

! WARNING

- The driver is always responsible for the tyre inflation pressure. Tyre pressure should be checked regularly » [page 157](#).
- The system cannot warn in case of very rapid loss of tyre pressure, e.g. in the event of a sudden puncture.

Save tyre pressure values



Fig. 122
Key for storing the pressure values

Read and observe ! on page 125 first.

Saving the tyre pressure values is undertaken as follows.

- Inflate all the tyres to the specified pressure.
- Switch on the ignition.
- Press the (U) » [Fig. 122](#) symbol icon and hold down.

The warning light (U) in the instrument cluster lights up.

An acoustic signal and the control indicator provide information about the storage of the tyre pressure values.

- Release the (U) icon button.

The tyre pressure values are always stored in the system, if one of the following events occurs.

- Change of tyre inflation pressure.
- Changing one or more wheels.
- Changing position of a wheel on the vehicle.
- Illumination of the warning light (U) in the instrument cluster.

! WARNING

Before storing the pressures, the tyres must be inflated to the specified inflation pressure » [page 157](#). When storing incorrect pressure values, the system could possibly not issue any warnings, even with a too low tyre pressure.

! CAUTION

The tyre pressure values are to be saved every 10,000 km or 1x annually to ensure correct system functioning.

Hitch and trailer

Hitch

Introduction

This chapter contains information on the following subjects:

Description	126
Adjusting the ready position	127
Fitting the ball head	127
Check proper fitting	128
Removing the ball head	128
Accessories	129

The maximum trailer drawbar load is **50 kg/h**.

! WARNING

- Check that the ball head is seated correctly and is secured in the mounting recess before starting any journey.
- Do not use the ball head, if it is not correctly inserted into the mounting recess and secured.
- Do not use the towing equipment if it is damaged or incomplete.
- Do not modify or adapt the towing equipment in any way.
- Never release the ball head while the trailer is still coupled.
- Keep the mounting recess of the towing equipment clean at all times. Such dirt prevents the ball head from being attached securely.

! CAUTION

- Take care with the ball bar - there is a risk of paint damage to the bumper.
- After removing the ball head, always place the cap on the mounting recess.

i Note

- Operation and maintenance of hitch » [page 139](#).
- Tow the vehicle by means of the detachable ball rod » [page 174](#).

Description

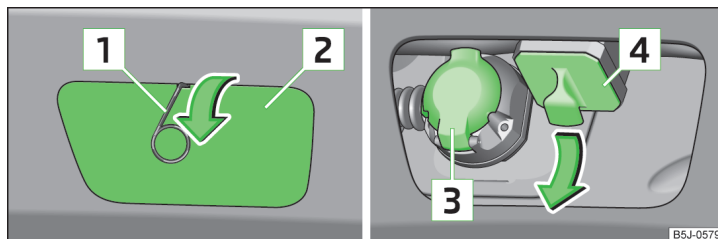

Fig. 123 Remove cover cap: on the rear bumper / for the receiving shaft

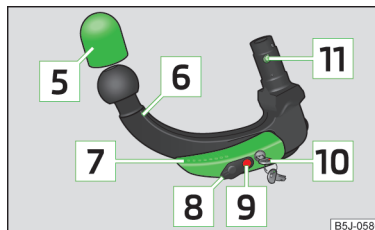

Fig. 124
Ball head

Read and observe **!** and **!** on page 126 first.

The ball head can be removed and is kept in the spare wheel well or in a compartment for the spare wheel in the luggage compartment.

Support for the towing device » [Fig. 123](#) and » [Fig. 124](#)

- 1 Clamps for removing the wheel trims
- 2 Cover in the rear bumper
- 3 13-pin power socket
- 4 Cover for the mounting recess
- 5 Dust cap
- 6 Ball head
- 7 Operating lever
- 8 Lock cap
- 9 Release pin

- 10** Key
- 11** locking ball

i Note

- The tool for removing the wheel trim is part of the vehicle tool kit » [page 166](#).
- If you lose the key, please get in touch with a specialist garage.

Adjusting the ready position

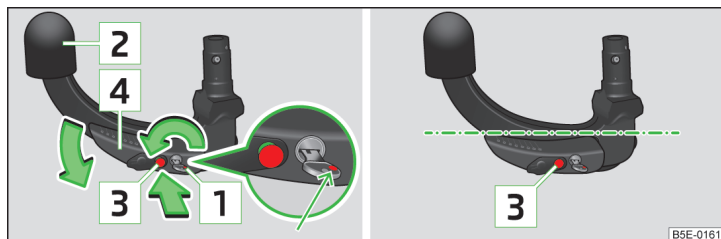

Fig. 125 Setting the ready position/ready position

i Read and observe **!** and **!** on page 126 first.

The coupling ball bar must be set prior to installation in the standby position. If this is not in the ready position, then this must be set to the standby position as follows.

- Grip the ball head below the protective cap **2** » [Fig. 125](#).
- Insert the key **1** into the lock so that the green marking is pointing upwards.
- Turn the key in direction of the arrow, so that the red marking is facing upwards.
- Press the release bolts **3** as far as the stop in the direction of the arrow and at the same time push the lever **4** downwards as far as it will go in the direction of the arrow.

Lever **4** remains locked in this position.

! CAUTION

In the ready position, the key cannot be removed nor turned to a different position.

Fitting the ball head

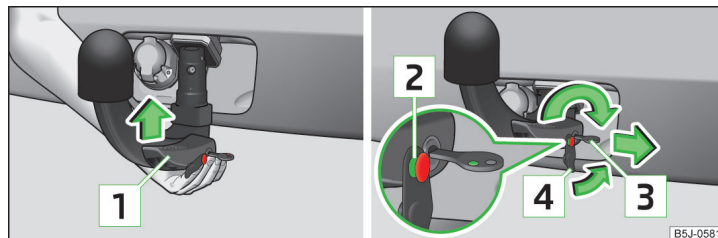

Fig. 126 Insert the ball head/lock the lock, and put the lock cover on

i Read and observe **!** and **!** on page 126 first.

- Remove the cover in the rear bumper **2** » [Fig. 123 on page 126](#) in the direction of the arrow using the tool for removing the wheel trims.
- Pull off the cover for the mounting recess **4** » [Fig. 123 on page 126](#) in the direction of the arrow » **!**.
- Adjust the ball head to the ready position » [page 127](#).
- Grip the tow bar **from underneath** » [Fig. 126](#) and insert into the mounting recess until you hear it click into place » **!**.

Lever **1** » [Fig. 126](#) **automatically** turns upwards and the release pin **2** pops out (its red and green parts are both visible) » **!**.

If the lever **1** does not automatically emerge, or if the release pin **2** does not pop out, remove the ball head from the mounting recess by turning the lever downwards as far as it will go. Clean the tapered surfaces on the ball head and the mounting recess.

- Lock the lock on the operating lever by turning the key by 180° to the right (see green marking **3** is visible) and remove the key in the direction of the arrow.
- Push cap **4** » [Fig. 126](#) onto the lock in the direction of the arrow » **!**.
- Check the ball head for secure mounting » [page 128](#).

! WARNING

- Carefully remove the cap for the mounting recess - there is a risk of hand injury.
- Keep your hands outside the lever's range of motion when attaching the ball head - there is a risk of fingers being injured!
- Never attempt to pull the operating lever upwards forcibly to turn the key. Doing so would mean the ball head is not attached correctly.

! CAUTION

- After removing the key, **always** replace the cover on the lock - there is a risk of the lock getting dirty.
- Remove the cover from the rear bumper with care - there is a risk of paint damage to the bumper and the cap.

i Note

Store cover **2** and cover **4** » Fig. 123 on page 126 in a suitable place in the luggage compartment after removing them.

Check proper fitting

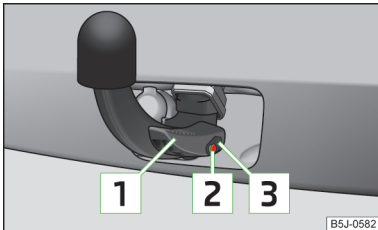

Fig. 127
Correctly secured ball head

📖 Read and observe **!** and **!** on page 126 first.

Check that the ball head is fitted properly each time before use.

Correctly secured ball head » Fig. 127

- ✓ The ball head does not come out of the mounting recess even after heavy "shaking".
- ✓ Lever **1** is up as far as it will go.
- ✓ The release pin **2** is completely exposed (both its red and green parts are visible).

- ✓ The key is removed.
- ✓ Cap **3** is on the lock.

! WARNING

Do not use the towing equipment unless the ball head was properly locked.

Removing the ball head

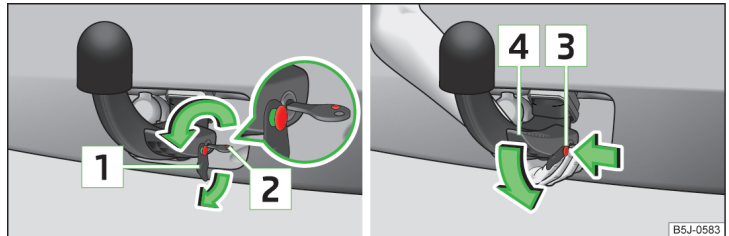

Fig. 128 Unlock the operating lever of the ball head/removing the ball head

📖 Read and observe **!** and **!** on page 126 first.

- Remove cover **1** from the lock in the direction of the arrow » Fig. 128 .
- Insert the key into the lock, so that its green marking is pointing upwards.
- Turn the key 180 ° to the left, so that its red marking **2** is visible.
- Grasp the ball head **from underneath**.
- Press the release pin **3** as far as the stop in the direction of the arrow and at the same time push the lever **4** downwards as far as it will go in the direction of the arrow.

The ball head is released in this position and falls freely into the hand. If it does not fall freely into the hand, use your other hand to push it upwards.

At the same time, the ball head latches into the ready position and is thus ready to be re-inserted into the mounting recess » **!**.

- Fit the cover for the mounting recess **4** » Fig. 123 on page 126 in the opposite direction to the arrow.
- Offer up the cap to the rear bumper **2** » Fig. 123 on page 126 aligning it with "check mark" in the lower bumper area.
- Push the cap in first on the left and right and then at the top. ▶

! WARNING

- Never allow the ball head to remain unsecured in the boot. This could cause damage to the boot upon sudden braking, and could put the safety of the occupants at risk.
- Never remove the tow bar while the trailer is still coupled.

! CAUTION

- If the lever is held firmly and not pushed downwards as far as it can go, it will go back up after the ball head is removed and will not latch into the ready position. The ball head then needs to be brought into this position before the next time it is fitted » [page 127, Adjusting the ready position](#).
- Tuck the ball bar in the ready position, with the golden key up, in the box - otherwise there is a risk of damage to the key!
- Do not use excessive force when handling the operating lever (e.g. do not step on it).

i Note

- We recommend that you put the protective cap on the ball before removing the ball head.
- Clean any dirt from the ball head before stowing it away in the box with the vehicle tool kit.

Accessories

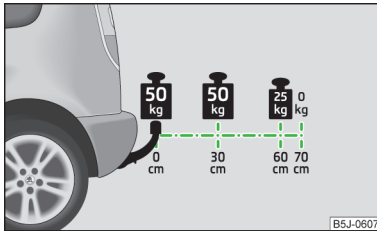

Fig. 129
Representation of the maximum permissible level of the ball head of the towing hitch and the permissible total weight of the accessories including the load depending on the load center of gravity

📖 Read and observe ! and ! on page 126 first.

An accessory can be mounted on the ball head of the towing hitch (e.g. bike carriers).

If this accessory is used, the maximum permissible overhang of the ball head of the towing hitch and the permissible gross vehicle weight of the accessories including load are to be checked.

The maximum permissible overhang of the ball head of the towing hitch is 70 cm » [Fig. 129](#).

The total permitted weight of the accessory including load changes with increasing distance of the centre of gravity of the load from the ball head of the towing hitch.

Distance of the centre of gravity of the load from the ball head	Permissible total weight of the accessory, including load
0 cm	50 kg
30 cm	50 kg
60 cm	25 kg
70 cm	0 kg

! WARNING

- Never exceed the permissible gross weight of the accessory including load - there is a risk of damaging the ball head of the towing hitch.
- Never exceed the permissible overhang of the ball head of the towing hitch - there is a risk of damaging the ball head of the towing hitch.

i Note

We recommend that you use accessories from ŠKODA Original Accessories.

Trailer

📖 Introduction

This chapter contains information on the following subjects:

Attaching and detaching trailers	130
Loading a trailer	130
Towing a trailer	131
Anti-theft alarm system	131

If your vehicle has already been factory-fitted with towing equipment or is fitted with towing equipment from ŠKODA Original Accessories, then it meets all of the technical requirements and national legal provisions for towing a trailer.

i Note

If there is an error in the trailer lighting system, check the fuses in the fuse box in the dashboard » [page 176](#).

Attaching and detaching trailers

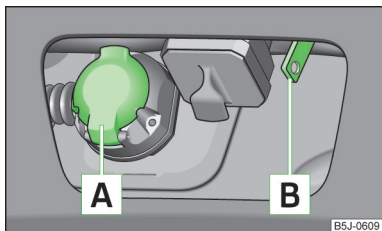

Fig. 130
13-pin socket and safety eye

Coupling

- › Lift off protective cap **5** » Fig. 124 on page 126 towards the top.
- › Place the trailer onto the ball.
- › Insert the trailer cable into the 13-pin socket **A** » Fig. 130 .

If the trailer that is to be towed has a **7-pin connector**, you can use a suitable adapter from ŠKODA Original Accessories to establish a connection to the electricity.

- › Hook the breakaway cable of the trailer to the security lock slot **B**.

Ensure that the breakaway cable of the trailer, when it is mounted into the safety eye on all trailer positions relative to the vehicle (sharp curves, reverse driving and the like), is seen to **sag**.

The **uncoupling** of the trailer is carried out in reverse order.

Exterior mirrors

You have to have additional exterior mirrors fitted if you are not able to see the traffic behind the trailer with the standard rear-view mirrors. The national legal requirements must be observed.

Headlights

The front of the vehicle can be lifted when a trailer is being towed and the headlights can dazzle other road users.

Adjust the headlight setting on the headlight range control » page 60, *Headlight beam adjustment*.

! WARNING

- Incorrectly or improperly connected electrical installations may cause malfunction of the entire vehicle electronics and lead to accidents and serious injury from electric shock.
- Work on the electrical system must only be carried out by specialist garages.
- Never directly connect the trailer's electrical system with the electrical connections for the tail lights or other current sources.
- After coupling the trailer and connecting up the power socket, check the rear lights on the trailer to ensure they are working.
- The handbrake on the towing vehicle must be applied when coupling and uncoupling the trailer.
- Never use the safety eyelet for towing!

Loading a trailer

The vehicle/trailer combination must be balanced, whereby the maximum permissible drawbar load must be utilised. If the drawbar load is too low, it jeopardises the performance of the vehicle/trailer combination.

Distribution of the load

Distribute the load in the trailer in such a way that heavy items are located as close to the axle as possible. Secure the items from slipping.

The distribution of the weight is very poor if your vehicle is unladen and the trailer is laden. Maintain a particularly low speed if you cannot avoid driving with this combination.

Tyre pressure

Correct the tyre inflation pressure on your vehicle for a "full load" » page 157.

Trailer load

The permissible trailer load must not be exceeded under any circumstances » page 183, *Technical data*.

The details given in the vehicle's technical documentation always take precedence over the details in the Owner's Manual.

The trailer loads specified apply only to altitudes up to 1,000 metres above mean sea level.

The engine output falls as altitude increases, as does the ability to climb. Therefore, for every additional 1000 m in height (or part), the maximum permissible towed weight must be reduced by 10 %.

The towed weight comprises the actual weights of the (loaded) towing vehicle and the (loaded) trailer.

The trailer and drawbar load information on the type plate of the towing equipment are merely test data for the towing equipment. The vehicle-specific values are detailed in the vehicle documents.

! WARNING

- The maximum permissible axle and drawbar load and the permissible weight of the trailer must not exceed - this could cause an accident!
- A sliding cargo can significantly adversely affect stability and driving safety - there is a risk of accident!

Towing a trailer

Driving speed

For safety reasons, do not drive faster than 80 km/h when towing a trailer.

Immediately reduce your speed as soon as even the slightest swaying of the trailer is detected. Never attempt to stop the trailer from "swaying" by accelerating.

Brakes

Apply the brakes in good time! If the trailer is fitted with a **trailer brake**, apply the brakes gently at first, then brake firmly. This will avoid brake jolts resulting from the trailer wheels locking.

On downhill sections shift down a gear in good time to also use the engine as a brake.

Engine overheating

The speed must be reduced immediately if the needle for the coolant temperature gauge moves into the right-hand area or the red area of the scale.

Stop and switch off the engine if the warning light  in the instrument cluster starts to flash. Wait a few minutes and check the level of coolant » [page 151](#), *Checking the coolant level*.

Further information » [page 41](#),   *Coolant*.

The coolant temperature can be reduced by switching on the heating.

! WARNING

- Always drive particularly carefully with the trailer.
- Adapt your speed to the conditions of the road surface and to the traffic situation.

i Note

If you tow a trailer frequently, you should also have your vehicle inspected between service intervals.

Anti-theft alarm system

When the vehicle is locked, the alarm is activated when the electrical connection to the trailer is interrupted.

Always switch off the anti-theft alarm system before a trailer is coupled or uncoupled » [page 53](#).

Conditions for including a trailer in the anti-theft alarm system.

- ✓ The vehicle is factory-fitted with an anti-theft alarm system and towing equipment.
- ✓ The trailer is electrically connected to the towing vehicle by means of the trailer socket.
- ✓ The electrical system of the vehicle and trailer is functional.
- ✓ The vehicle is locked with the vehicle key and the anti-theft alarm system is activated.

! CAUTION

For technical reasons, trailers with rear LED lights cannot be connected to the anti-theft alarm system.

General Maintenance

Car care

Services, modifications and technical alterations

Introduction

This chapter contains information on the following subjects:

Vehicle operating under different weather conditions	132
Statutory checks	132
ŠKODA Service Partners	133
ŠKODA Original parts	133
ŠKODA Original accessories	133
Spoiler	134
Airbags	134

The instructions and guidelines from ŠKODA AUTO a.s. must be observed when carrying out all modifications, repairs or technical alterations to your vehicle.

Adhering to these instructions and guidelines helps ensure road safety and helps keep your vehicle in a good technical condition. After carrying out modifications, repairs or technical alterations, the vehicle will comply with German road transport regulations (StVZO)

Always consult a ŠKODA Partner » [page 133](#) before buying accessories or parts, or before carrying out any modifications, repairs or technical alterations to your vehicle.

WARNING

- Works on your vehicle, which have been carried out unprofessionally, can cause operational faults – risk of accident!
- Interference on the electronic components and their software can lead to operational faults. This interference can also impair not directly affected systems because of the networking of the electronic components. The operational safety of the vehicle may be at significant risk and can lead to increased wear of parts.

For the sake of the environment

Technical documents regarding alterations carried out on the vehicle must be kept by the vehicle user in order to be handed over to the recyclers at a later date. This ensures that the vehicle is recycled in an environmentally sound manner.

Note

- We recommend only having these modifications and technical alterations carried out by a specialist garage.
- Any damage caused by technical alterations made without the approval of the manufacturer is excluded from the warranty » *Service schedule*.
- The ŠKODA Partner does not assume any liability for products that have not been approved by ŠKODA AUTO a.s. even though these may be products with an operational approval or that have been approved by a government testing institute.
- We advise you only to use ŠKODA Original Accessories and ŠKODA Original Parts which have been expressly approved for use on your vehicle. Reliability, safety and suitability for your vehicle are guaranteed with these.
- ŠKODA Original Accessories and ŠKODA Original Parts can be purchased from ŠKODA Partners, who will also perform the professional assembly of the purchased parts.

Vehicle operating under different weather conditions

 **Read and observe  on page 132 first.**

If you would like to operate your vehicle in countries other than those with its intended weather conditions, you should contact a ŠKODA Partner.

He will advise you if certain precautions need to be taken to ensure the full functioning of the vehicle as well as to prevent damage.

This involves, for example, the coolant, battery replacement and the like.

Statutory checks

 **Read and observe  on page 132 first.**

Many countries have legislation requiring the operational reliability and road worthiness and/or exhaust gas properties of a vehicle to be tested at specific intervals. These tests can be carried out by workshops or testing stations that have been legally authorised for this purpose. ►

The ŠKODA Service Partners are up-to-date on the legally required tests and will prepare the vehicle for the tests as part of a service operation if required, or will be responsible for carrying out these tests. The specialist garages can carry out the specified tests directly, if required by the customer, if they are authorised to do so. This saves you time and money.

Even if you want to take your vehicle to an officially approved test centre for prior checking in preparation of a legally required test, we recommend that you consult the service consultant of your ŠKODA Service Partner beforehand.

Based on their appraisal, the service consultant will tell you which areas you should focus on in order to ensure that your vehicle will pass the technical test without any problems. This allows you to avoid additional expenses resulting from a possible subsequent test.

ŠKODA Service Partners

 **Read and observe**  on page 132 first.

ŠKODA Service Partners are equipped with modern, specially developed tools and equipment. Here, trained specialists have access to a comprehensive range of ŠKODA Original Parts and ŠKODA Original Accessories for carrying out modifications, repairs and technical alterations.

All ŠKODA service partners operate according to the latest guidelines and instructions from ŠKODA AUTO a.s. All service and repair work is therefore carried out on time and to the appropriate quality. Adhering to these instructions and guidelines helps ensure road safety and helps keep your vehicle in a good technical condition.

ŠKODA Service Partners are therefore properly prepared to service your vehicle and to provide quality work. We therefore advise you to have all modifications, repairs and technical alterations to your vehicle carried out by a ŠKODA Service Partner.

ŠKODA Original parts

 **Read and observe**  on page 132 first.

We recommend the use of ŠKODA Genuine Parts for your vehicle, since these parts are approved by ŠKODA AUTO a.s. They correspond exactly to ŠKODA AUTO a.s. specifications in respect of design, dimensional accuracy and material and are identical to the components used in the batch production.

ŠKODA AUTO a.s. can guarantee the safety, suitability, and long life of these products. We therefore recommend that you only use ŠKODA Genuine Parts.

ŠKODA AUTO a.s. supplies the market with a complete range of ŠKODA Genuine Parts not only while the model is still in production but with wear-and-tear parts for at least 15 years after the end of series production and with all other vehicle parts for at least 10 years.

ŠKODA service partners are liable for any defects in ŠKODA original parts for a period of 2 years after sale in accordance with materials defect liability under the law unless otherwise agreed in the purchase agreement. You should keep the confirmed warranty certificate and the receipt for these components for this period, so that the commencement of the warranty term may be verified.

Body repairs

ŠKODA vehicles are designed so that if the body suffers damage, it is only necessary to replace those parts which are in fact damaged.

Before you decide to have damaged body parts replaced, however, you should first contact your specialist garage to determine whether or not such parts can also be repaired. Repairs to body parts are usually cheaper.

ŠKODA Original accessories

 **Read and observe**  on page 132 first.

You should note the following if you wish to fit accessories to your vehicle:

We recommend that you use ŠKODA Genuine Accessories in your vehicle. ŠKODA AUTO a.s. offers a warranty on the reliability, safety and suitability for your particular vehicle of these accessories. Although we constantly monitor the market, we are not able to assess or offer a warranty on other products even though in some instances such products may have a type approval or may have been approved by a nationally recognised approval authority.

All accessory products go through a fastidious process of technical development (technical tests) and quality inspection (customer tests), and only if all tests are positive does the product become a ŠKODA Genuine Accessory.

Our ŠKODA Genuine Accessories service also provides expert advice and professional fitting if requested by the customer.

ŠKODA Service Partners are liable for any defects in ŠKODA Genuine Parts for a period of 2 years after installation or delivery in accordance with materials defect liability legislation, unless otherwise agreed in the purchase contract or in ►

any other agreements. You should keep the confirmed warranty certificate and the receipt for these accessories for this period, so that the commencement of the warranty term may be verified.

In addition, ŠKODA Service Partners also stock a range of suitable car care products as well as those parts which are subject to natural wear and tear, such as tyres, batteries, bulbs and wiper blades.

I Note

The accessories authorized by ŠKODA AUTO a.s. will be offered by the ŠKODA Partners in all countries where ŠKODA AUTO a.s. has a sales and service network. This will usually be in the form of a printed catalogue of Original ŠKODA Accessories, in the form of separate printed brochures or in the form of offers for ŠKODA Genuine Accessories on the ŠKODA Partner's website.

Spoiler

 **Read and observe  on page 132 first.**

If your new vehicle is fitted with a spoiler on the front bumper in combination with the spoiler on the luggage compartment lid, then the following instructions must be adhered to.

- > For safety reasons, the vehicle must only be fitted with a spoiler on the front bumper in combination with the associated spoiler on the luggage compartment lid.
- > This kind of spoiler cannot be left on the front bumper either on its own, in combination with another spoiler not on the luggage compartment lid or in combination with an unsuitable spoiler on the luggage compartment lid.
- > We recommend that you consult the ŠKODA service partner for any repairs to or replacement, addition or removal of spoilers.

! WARNING

- If work on your vehicle's spoilers is not carried out properly, this can lead to operational faults - risk of accident and serious injuries.
- If a front spoiler, full wheel trim, etc. is mounted retrospectively, it must be ensured that the air supply to the front wheel brakes is not reduced. The front brakes may overheat, which can have a negative impact on the functioning of the braking system – there is a risk of an accident!

Airbags

 **Read and observe  on page 132 first.**

The system components of the airbag system can be situated in the front bumper, doors, front seats, roof lining or body.

! WARNING

Any work on the airbag system including the installation and removal of system components due to other repair work (e.g. removal of the steering wheel) must only be carried out by a specialist garage.

- Modifications, repairs and technical alterations that have been carried out unprofessionally can cause damage and operational faults, and can also seriously impair the effectiveness of the airbag system – risk of accident and fatal injury!
- The airbag system will then have to be replaced if the airbag is deployed. Airbag modules cannot be repaired.

! WARNING

Information on the use of the airbag system

- It is prohibited to manipulate individual parts of the airbag system, as this might result in the airbag being deployed.
- Never install any airbag parts into the vehicle that have been removed from old cars or have been recycled.
- Never install damaged airbag parts in the vehicle. The airbags may then not be deployed properly or even at all in the event of an accident.
- No modifications of any kind must be made to parts of the airbag system.

! WARNING

- A change to the vehicle's wheel suspension, including the use of non-approved wheels and tire combinations, can alter the functioning of the airbag system - risk of accident and fatal injury!
- Never make any changes to the front bumper or the bodywork.

Washing vehicle

Introduction

This chapter contains information on the following subjects:

Washing by hand	135
Automatic car wash systems	135
Washing with a high-pressure cleaner	136

The best way to protect your vehicle against harmful environmental influences is **frequent** washing.

How often the vehicle should be washed depends on factors such as:

- Frequency of use.
- Parking situation (garage, under trees etc.).
- Season.
- Weather conditions.
- Environmental influences.

The longer insect residues, bird droppings, tree sap, road and industrial dust, tar, soot particles, road salt and other aggressive deposits remain adhering to the paintwork of your vehicle, the more detrimental their destructive effect can be. High temperatures, such as those caused by intensive sun's rays, accentuate this caustic effect.

It is essential to also thoroughly clean the **underside of the vehicle** at the end of the winter.

! WARNING

- When washing your vehicle in the winter: Water and ice in the braking system can affect the braking efficiency - risk of accident!
- Only wash the vehicle when the ignition is switched off - risk of accident!

! CAUTION

Do not wash your vehicle in bright sunlight - risk of paint damage.

🌿 For the sake of the environment

Only wash the vehicle at washing bays intended for this purpose.

Washing by hand

📖 Read and observe **!** and **!** on page 135 first.

Soak the dirt with plenty of water and rinse as well as possible.

Clean the vehicle with a soft **sponge**, a **washing glove** or a **washing brush**. Work from the top to the bottom - starting with the roof.

Only use a **car shampoo** for stubborn dirt.

Wash out the sponge or washing glove thoroughly at short intervals.

Clean wheels, door sills and similar parts last. Use a second sponge for such areas.

Give the vehicle a good rinse after washing it and dry it off using a chamois leather.

! CAUTION

- When washing the car by hand, protect your hands and arms from sharp-edged metal parts (e.g. when cleaning the underfloor, the inside of the wheel housings or the wheel trims, etc.) - There is a risk of cuts!
- Only apply slight pressure when cleaning the vehicle's paintwork.

Automatic car wash systems

📖 Read and observe **!** and **!** on page 135 first.

The usual precautionary measures must be taken before washing the vehicle in an automatic car wash system (e.g. closing the windows and the sliding/tilting roof etc.).

If your vehicle is fitted with any particular attached parts, such as a spoiler, roof rack system, two-way radio aerial etc., it is best to consult the operator of the car wash system beforehand.

After an automatic wash with wax treatment, the lips of the wipers should be cleaned with cleaning agents specially designed for the purpose, and then degreased.

! WARNING

Fold in the exterior mirrors to prevent damage before washing the vehicle in an automatic car wash system.

Washing with a high-pressure cleaner

 Read and observe  and  on page 135 first.

When washing the vehicle with a high-pressure cleaner, the instructions for use of the equipment must be observed. This applies in particular to the **pressure** used and to the **spraying distance**.

Maintain a sufficiently large distance to the parking aid sensors and soft materials such as rubber hoses or insulation material.

WARNING

Never use circular spray nozzles or dirt cutters!

CAUTION

- If washing the vehicle in the winter using a hose or high-pressure cleaner, ensure that the jet of water is not aimed directly at the locking cylinders or the door/panel joints - risk of freezing!
- To avoid damaging the parking aid sensors while cleaning with high-pressure cleaners or steam jets, the sensors must only be directly sprayed for short periods while a minimum distance of 10 cm must be observed.
- The temperature of the water used for cleaning must not exceed 60 °C - risk of damaging the vehicle.
- See also Washing cars with decorative films using a high-pressure cleaner » page 137 .

Taking care of your vehicle exterior

Introduction

This chapter contains information on the following subjects:

Taking care of your vehicle's paintwork	137
Plastic parts	137
Rubber seals	137
Chrome parts	137
Decorative films	137
Windows and exterior mirrors	138
Headlight lenses	138
Door lock cylinders	138
Cavity protection	138

Jack	138
Trailer fitting and mounting recess	139
Wheels	139
Underbody protection	139

Regular and proper care help to retain the efficiency and **value** of your vehicle. It may also be one of the requirements for the acceptance of warranty claims relating to corrosion damage and paint defects on the bodywork.

We recommend using vehicle care products from ŠKODA Original Accessories. These are available from ŠKODA Partners. The usage instructions on the package must be observed.

WARNING

- Vehicle care products may be harmful to your health if not used according to the instructions.
- Always keep the vehicle care products safe from people who are not completely independent, e.g. children - there is a danger of poisoning!
- Protect your hands and arms from sharp-edged metal parts when cleaning the underfloor, the inside of the wheel housings or the wheel trims - risk of cuts!

CAUTION

- Do not use any insect sponges, rough kitchen sponges or similar cleaning products - risk of damaging the paintwork surface.
- Cleaner that contain solvents can damage the material being cleaned.

For the sake of the environment

Used cans of vehicle care product represent hazardous waste that is harmful to the environment. These must be disposed of in accordance with national legislation.

Note

Because of the special tools and knowledge required, and to avoid any potential problems with the cleaning and care of the interior of your vehicle, we recommend that cleaning and care of the interior of your vehicle be carried out by a ŠKODA Service Partner.

Taking care of your vehicle's paintwork

📖 Read and observe **!** and **!** on page 136 first.

Minor paint damage such as scratches, scuffs or stone chips should be treated immediately if possible, using **touch-up pens** or **sprays**.

Preserving the vehicle paintwork

A thorough wax treatment provides the vehicle's paintwork with highly effective protection against harmful environmental influences.

The vehicle must be treated with a high-quality hard wax polish at the latest, when no more drops form on the clean paintwork.

A new layer of a high-quality hard wax polish can be applied to the clean bodywork after it has dried thoroughly.

Even if you use a wax preserver regularly we still recommend that you treat the paintwork of the vehicle at least twice a year with hard wax.

Polishing

Polishing is necessary if the vehicle's paintwork has become unattractive and if it is no longer possible to achieve a gloss with wax preservatives.

If the polish does not contain any preserving elements, the paint must be treated with a preservative afterwards.

! CAUTION

- Never apply wax to the windows.
- Mat painted or plastic parts must not be treated with polishing products or hard waxes.
- Do not polish the paintwork in a dusty environment - risk of paint scratches.
- Do not apply any paint care products to door seals or window guides.
- If possible, do not apply any paint care products to parts of the bodywork that come into contact with door seals or window guides.

Plastic parts

📖 Read and observe **!** and **!** on page 136 first.

Clean plastic parts with a damp cloth.

If this method does not completely clean the plastic parts, use cleaning products specially designed for this purpose.

! CAUTION

Do not use paint care products on plastic parts.

Rubber seals

📖 Read and observe **!** and **!** on page 136 first.

All door seals and window guides are factory-treated with a colourless matt varnish layer to prevent the freezing of painted body parts and to protect against driving noise.

Do not treat the door seals and window guides with **any** products.

! CAUTION

Applying additional treatments to the seals can corrode the protective coating, and driving noise may occur.

Chrome parts

📖 Read and observe **!** and **!** on page 136 first.

First clean the chrome parts with a damp cloth and then polish them with a soft, dry cloth.

If this method does not completely clean chrome parts, use a specific chrome care product.

! CAUTION

Do not polish the chrome parts in a dusty environment - risk of surface scratches.

Decorative films

📖 Read and observe **!** and **!** on page 136 first.

Wash the films with a mild soap solution and clean, warm water. Never use harsh cleaning products or chemical solvents, as this could damage the films.

The following instructions must be followed when washing the vehicle with a high-pressure cleaner:

- The minimum distance between the nozzle and the vehicle body should be 50 cm.
- Keep jet perpendicular to the film surface. ▶

- > The maximum water temperature is 50 °C.
- > The maximum water pressure is 80 bar.

CAUTION

In the winter months, do not use an ice scraper to remove ice and snow from the areas with films. Do not use any other objects to remove frozen layers of snow or ice – risk of film damage.

Windows and exterior mirrors

 Read and observe  and  on page 136 first.

Use a plastic ice scraper for removing snow and ice from the windows and mirrors.

Regularly clean windows from the inside with clean water.

Dry the glass surfaces with a clean chamois leather or a cloth intended for this purpose.

When drying the windows after washing the vehicle, do not use window leathers that have been used to polish the bodywork. Residues of preservatives in the window leather can make the window dirty and reduce visibility.

CAUTION

- The ice scraper should not be moved forward and backward but in one direction to avoid any damage to the surface of the glass.
- Snow or ice that is contaminated with coarse dirt such as fine gravel, sand or salt must not be removed from the windows and mirrors – risk of damage to the surface of the windows and mirrors.
- Do not remove snow or ice from glass parts using warm or hot water – risk of cracks forming in the glass.
- When removing snow or ice from windows and mirror lenses ensure that the paintwork of the vehicle is not damaged.
- Do not clean the inside of the windows with sharp-edged objects or corrosive and acidic cleaning agents – there is a risk of damaging the heating elements or window aerial.

Headlight lenses

 Read and observe  and  on page 136 first.

Clean plastic front headlight lenses using clean, warm water and soap.

CAUTION

- Never wipe headlights to dry.
- Do not use any sharp objects to clean the plastic lenses, as this may damage the protective paintwork and consequently cause cracks to form on the headlight lenses.
- Do not use any harsh cleaning products or chemical solvents to clean the headlights, as this could damage the headlight lenses.

Door lock cylinders

 Read and observe  and  on page 136 first.

Specific products must be used for de-icing door lock cylinders.

CAUTION

When washing your vehicle, ensure as little water as possible gets into the locking cylinders.

Cavity protection

 Read and observe  and  on page 136 first.

All the cavities of your vehicle which are at risk from corrosion are protected for life by a layer of **protective wax** applied in the factory.

This wax protection does not need to be inspected or re-applied.

If any small amount of wax flow out of the cavities at high temperatures, these must be removed with a plastic scraper and the stains cleaned using a petroleum cleaner.

WARNING

Safety regulations should be observed when using petroleum cleaner to remove wax – risk of fire!

Jack

 Read and observe  and  on page 136 first.

The jack is maintenance-free.

If necessary, the moving parts of the jack should be lubricated with a suitable lubricant.

Trailer fitting and mounting recess

 Read and observe  and  on page 136 first.

Close the mounting recess with the cap to prevent any ingress of dirt.

If dirt is present, clean the inner surfaces of the mounting recess and treat with a suitable preservative.

Always check the ball head before hitching a trailer. Apply a suitable grease, if necessary.

Fit the protective cap when stowing away the ball head to protect the luggage compartment against dirt.

CAUTION

Apply grease to the inner part of the mounting recess. Make sure you do not remove any grease.

Wheels

 Read and observe  and  on page 136 first.

Wheel rims

Also thoroughly wash the wheel rims when washing the vehicle on a regular basis.

Regularly remove salt and brake abrasion, otherwise the rim material will be corroded.

Damage to the paint layer on the wheel rims must be touched up immediately.

Light alloy wheels

After washing thoroughly and treat the wheel rims with a protective product for light alloy wheels. Products which cause abrasion must not be used to treat the wheel rims.

CAUTION

Severe layers of dirt on the wheels can also result in wheel imbalance. This may show itself in the form of a wheel vibration which is transmitted to the steering wheel which, in certain circumstances, can cause premature wear of the steering. This means it is necessary to remove the dirt.

Underbody protection

 Read and observe  and  on page 136 first.

The underside of your vehicle is protected for life against chemical and mechanical influences.

When driving, it cannot be guaranteed that no damage to the **protective layer** will occur.

We recommend having the protective layer underneath the vehicle and the chassis checked — preferably before the beginning of winter and at the end of winter.

WARNING

Never use additional underbody protection or anti-corrosion agents for exhaust pipes, catalytic converters, diesel particle filters or heat shields. When the engine reaches its operating temperature, these substances may ignite - risk of fire!

Taking care of the interior

Introduction

This chapter contains information on the following subjects:

Natural leather	140
Synthetic leather, fabrics and Alcantara®	141
Seat covers	141
Seat belts	141

Regular and proper care helps to ensure efficiency and maintain the **value** of your vehicle.

We recommend using vehicle care products from ŠKODA Original Accessories. These are available from ŠKODA Partners. The usage instructions on the package must be observed.

WARNING

- Vehicle care products may be harmful to your health if not used according to the instructions.
- Always keep the vehicle care products safe from people who are not completely independent, e.g. children - there is a danger of poisoning!

CAUTION

- Be sure to check clothing for colourfastness to avoid any damage or visible stains on the material (leather), panels and textiles.
- Remove fresh stains such as those from ball-point pens, ink, lipstick, shoe polish, etc., from the material (leather), panels and textiles as quickly as possible.
- Air fresheners and scents can be hazardous to health when the temperature inside the vehicle is high.
- Do not attach scent dispensers or air fresheners to the dash panel – risk of damage to the dash panel.
- Do not stick any stickers on the inside of the rear windows, the rear side windows and in the vicinity of the heating elements on the windscreen or near the window aerial. These may get damaged.
- Do not clean the roof panelling with a brush – risk of damage to the surface of the panelling.
- Cleaner that contain solvents can damage the material being cleaned.
- Apply only a small amount of the cleaning and care product.

For the sake of the environment

Used cans of vehicle care product represent hazardous waste that is harmful to the environment. These must be disposed of in accordance with national legislation.

Note

Because of the special tools and knowledge required, and to avoid any potential problems with the cleaning and care of the interior of your vehicle, we recommend that cleaning and care of the interior of your vehicle be carried out by a ŠKODA Service Partner.

Natural leather

 **Read and observe  and  on page 139 first.**

Leather is a natural material with specific properties, and requires regular cleaning and maintenance.

The leather should be cleaned on a regular basis depending on the amount of wear-and-tear.

Dust and dirt in the pores and folds act as abrasive materials. This leads to severe corrosion and the premature brittleness of the leather surface.

We recommend that you remove dust **regularly and at short intervals** using a cloth or vacuum cleaner.

Clean soiled leather surfaces with a water-dampened cotton or woollen cloth and then dry with a clean, dry cloth **>> **.

Clean **severely soiled areas** with a cloth soaked in a mild soap solution (2 tablespoons of neutral soap to 1 litre of water).

To **remove stains**, use a cleaning agent specially designed for this purpose.

Treat the leather regularly and at suitable intervals using a suitable leather care product.

CAUTION

- Ensure that no part of the leather is soaked through during cleaning and that no water gets into the seams. Otherwise, the leather could become brittle or cracked.
- Avoid leaving the vehicle for lengthy periods in bright sunlight to avoid the leather from bleaching. If the vehicle is parked in the open for lengthy periods, protect the leather from direct sunlight by covering it.
- Sharp-edged objects on items of clothing such as zip fasteners, rivets, sharp-edged belts, jewellery and pendants may leave permanent scratches or signs of rubbing on the surface. Such damage cannot be subsequently recognised as a justified complaint.
- The use of a mechanical steering wheel lock may damage the leather surface of the steering wheel.
- Use a care cream with light blocker and impregnation effect on a regular basis and each time after cleaning. The cream nourishes the leather, allows it to breathe and keeps it supple and also provides moisture. It also creates surface protection.
- Some clothing materials, e.g. dark denim, do not have sufficient colour fastness. This can cause damage or clearly visible discolouration to seat covers, even when used correctly. This applies particularly to light-coloured seat covers. This does not relate to a fault in the seat cover, but rather to poor colour fastness of the clothing textiles.

Note

When using the vehicle, minor visible changes may occur to the leather parts of the covers (e.g. wrinkles or creases) as a result of the stress applied to the covers.

Synthetic leather, fabrics and Alcantara®

📖 Read and observe **!** and **!** on page 139 first.

Artificial leather

Clean artificial leather with a damp cloth.

If this method does not completely clean the artificial leather, use a mild soap solution or cleaning products specially designed for this purpose.

Fabric

Clean upholstery cover materials and cloth trims on doors, boot cover, etc. using specific cleaning agents, e.g., dry foam.

Use a soft sponge, brush, or commercially available microfibre cloth.

Use a cloth and special detergent to clean the headlining.

Remove any lumps on the cover fabric and any fabric residue using a brush.

Remove stubborn hair using a "cleaning glove".

Alcantara®

Dust and fine dirt particles in pores, creases and seams may chafe and damage the surface.

If you leave your vehicle parked in the open for lengthy periods, protect the Alcantara® seat upholstery from direct sunlight to prevent fading.

Minor changes in colour caused by use are normal.

! CAUTION

- Do not use leather cleaners on Alcantara® seat upholstery.
- Do not use solvents, floor wax, shoe cream, stain remover or similar agents on Alcantara® seat upholstery.
- Avoid leaving the vehicle in bright sunlight for long periods of time in order to stop the fabric from bleaching. If the vehicle is parked outside for long periods of time, cover the fabric to protect it from direct sunlight.
- Some clothing materials, e.g. dark denim, do not have sufficient colour fastness. This can cause damage or clearly visible discolouration to seat covers, even when used correctly. This applies particularly to light-coloured seat covers. This does not relate to a fault in the seat cover, but rather to poor colour fastness of the clothing textiles.

Seat covers

📖 Read and observe **!** and **!** on page 139 first.

Electrically heated seats

Do not clean the covers **by moistening**, as this can damage the seat heating system.

Use a specific cleaning agent such as dry foam or similar to clean the covers.

Seats without seat heating

Thoroughly vacuum the seat covers with a vacuum cleaner before cleaning.

Clean the seat covers with a damp cloth or cleaning products specially designed for this purpose.

Indented points arising on the fabrics by everyday use, can be removed by brushing against the direction of hair with a damp brush.

Always clean all parts of the covers, so that there are no visible edges. Then allow the seat to dry completely.

! CAUTION

- Regularly remove dust from the seat covers using a vacuum cleaner.
- Electrically heated seats must not be dried after cleaning by switching on the heater.
- Do not sit on wet seats - risk of seat deformation.
- Always clean the seats "from seam to seam".

Seat belts

📖 Read and observe **!** and **!** on page 139 first.

The belt webbing must always be kept clean.

Wash dirty seat belts with mild soapy water.

Remove coarse dirt with a soft brush.

Dirty belt webbing may impair the correct functioning of the inertia reel.

! WARNING

- The seat belts must not be removed for cleaning.
- Never clean the seat belts chemically as chemical cleaning products could destroy the fabric.

! WARNING (Continued)

- The seat belts must not be allowed to come into contact with corrosive liquids (e.g. acids).
- Check the condition of all the seat belts on a regular basis. If any damage to the belt webbing, seat belt connections, inertia reel or lock is detected, the seat belt must be replaced by a specialist garage.
- The seat belts must be fully dried before being rolled up.

Inspecting and replenishing

Fuel

Introduction

This chapter contains information on the following subjects:

Refuelling	143
Unleaded petrol	143
Diesel fuel	144

The correct grades of fuel for your vehicle are stated on a sticker affixed to the inside of the fuel filler flap » [Fig. 131 on page 143](#) - .

! WARNING

The national legal requirements must be observed if carrying a spare canister in the vehicle. We do not recommend carrying any fuel canisters in your vehicle for safety reasons. In the event of an accident, these canisters can become damaged and fuel may escape – risk of fire!

! CAUTION

- Never drive until the fuel tank is completely empty! The irregular supply of fuel can cause misfiring, which can result in damage to parts of the engine and the exhaust system.
- Immediately remove any fuel that has spilled onto the vehicle's paintwork – risk of paint damage!
- If the vehicle was not purchased in the country in which it was intended to be operated, you should check whether the fuel specified by the manufacturer is offered in the country where the vehicle will be operated. You should also perhaps check whether the manufacturer has recommended a different fuel for operation of the vehicle in the country concerned. If no prescribed fuel is available, then you must check whether it is permitted by the manufacturer to operate the vehicle with another fuel type.

Refuelling

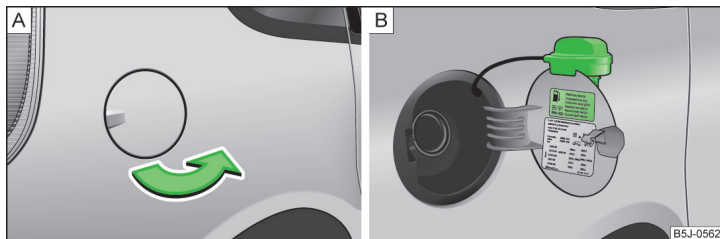

Fig. 131 Open fuel filler flap / tank cap

Read and observe **!** and **!** on page 142 first.

Open fuel filler flap

- Open the fuel filler flap with one hand » Fig. 131 - **A**.
- Hold the fuel filler cap on the fuel filler tube with one hand and unlock it by moving it to the left with the vehicle key.
- Unscrew the filler cap by turning it anticlockwise and clip the cap on the top of the fuel filler flap » Fig. 131 - **B**.

Closing the filler cap

- Turn the filler cap to the right until it clicks into place.
- Hold the fuel filler cap on the fuel filler tube with one hand and lock it by turning the vehicle key to the right and remove the key.
- Close the filler cap.

! CAUTION

- Before refuelling it is necessary to switch off the auxiliary heating system (auxiliary heating and ventilation).
- The fuel tank is full just as soon as the pump nozzle switches off for the first time, provided the nozzle has been operated properly. Do not continue filling the fuel tank otherwise the expansion volume is filled up.

i Note

The fuel tank has a capacity of about **55 litres**, including a reserve of approx. **7 litres**.

¹⁾ In Germany also DIN 51626-1 or E10 for unleaded petrol with octane rating 95 or 91 or DIN 51626-2 or E5 for unleaded petrol with octane rating 95 or 98.

Unleaded petrol

Read and observe **!** and **!** on page 142 first.

The vehicle can only be operated with **unleaded petrol** that meets the **EN 228¹⁾** standard.

All petrol engines can be operated using petrol with a **maximum of 10%** bioethanol (**E10**).

Specified fuel - unleaded petrol 95/91 or 92 or 93 RON

Use unleaded fuel with an octane rating of **95 RON**. Unleaded petrol with the octane ratings **91 or 92 or 93 RON** can also be used, but may result in a slight loss in performance and slightly increased fuel consumption.

Prescribed fuel - unleaded petrol min. 95 RON

Use unleaded fuel with an octane rating of **95 RON** or higher.

If unleaded gasoline is not available with the octane number **95 RON**, in an emergency petrol with the octane rating of **91 or 92 or 93 RON** can be used to fill the tank, but this leads to a slight loss of performance and a slightly increased fuel consumption » **!**.

Prescribed fuel - unleaded petrol 98/(95) RON

Use unleaded fuel with an octane rating of **98 RON** or higher. Unleaded petrol **95 RON** can also be used but results in a slight loss in performance.

In an emergency, if unleaded petrol with an octane rating of **98 RON** or **95 RON** is not available, you may refuel with petrol with an octane rating of **91 or 92 or 93 RON** » **!**.

Fuel additives

Unleaded petrol complying with EN 228 ¹⁾ meets all the conditions for a smooth-running engine. We therefore recommend that no fuel additives are used. This can result in considerable damage to parts of the engine or the exhaust system. ▶

CAUTION

- Even one filling of the tank with petrol that does not meet the standards can lead to serious damage to parts of the exhaust system!
- If a fuel other than unleaded fuel which complies to the above mentioned standards (e.g. leaded petrol) is used by mistake, do not start the engine or switch on the ignition! Engine parts could be significantly damaged!

CAUTION

- If, in an emergency, the vehicle has to be refuelled with petrol of a lower octane number than the one prescribed, the journey must only be continued at medium engine speeds and a low engine load. Driving at high engine revs or a high engine load can severely damage the engine! Refuel using petrol of the prescribed octane number as soon as possible.
- Engine parts can be damaged if petrol with a lower octane number than the one prescribed is used.
- Even in the event of an emergency, petrol of a lower octane number than **91 RON** must not be used, otherwise the engine can be severely damaged!

CAUTION

In no case may fuel additives with metal components be used, especially not with manganese and iron content. There is a risk of causing considerable damage to parts of the engine or exhaust system!

CAUTION

Fuels with metal components, such as LRP (lead replacement petrol) must not be used. There is a risk of causing considerable damage to parts of the engine or exhaust system!

Note

- Unleaded petrol that has a higher octane number than that required by the engine can be used without limitations.
- The use of petrol with an octane rating higher than **95 RON** in does not result in either a noticeable increase in power nor lower fuel consumption in vehicles for which unleaded petrol **95/91, 92 or 93 RON** is specified.
- On vehicles using prescribed unleaded petrol of **min. 95 RON**, the use of petrol with a higher octane number than **95 RON** can increase the power and reduce fuel consumption.

¹⁾ In Germany also DIN 51628, in Austria ÖNORM C 1590, in Russia GOST R 52368-2005 / EN 590:2004.

²⁾ In Germany complying with standard DIN 52638, in Austria ÖNORM C 1590, in France EN 590.

Diesel fuel

 **Read and observe  and  on page 142 first.**

The vehicle can only be operated with **diesel fuel** that meets the **EN 590¹⁾** standard.

All diesel engines can be operated using diesel fuel with a **maximum of 7% bi-odiesel (B7)²⁾**.

Operation in winter - Winter-grade diesel fuel

In the cold season, only use "winter-grade diesel fuel" which will still operate properly even at a temperature of -20 °C.

It is often the case in countries with different climatic conditions that diesel fuels available have a different temperature characteristic. ŠKODA Partners and filling stations in the relevant country will be able to provide you with information regarding the diesel fuels available.

Diesel fuel additives

The diesel fuel in accordance with the prescribed standards meets all the conditions for a smooth running engine. We therefore recommend that no fuel additives are used. This can result in considerable damage to parts of the engine or the exhaust system.

CAUTION

- Just filling the tank once with diesel fuel that does not comply with the standard, can cause severe damage to parts of the engine, the fuel and exhaust system!
- If a different fuel other than diesel fuel, which complies to the above mentioned standards (e.g. petrol) is used, do not start the engine or switch on the ignition! Engine parts could be significantly damaged!
- Water which has collected in the fuel filter can cause engine faults. ▶

! CAUTION

- The vehicle cannot be operated with biofuel **RME**, therefore this fuel must not be filled in the tank and used for driving the vehicle. The use of biofuel **RME** can cause considerable damage to parts of the engine or fuel system.
- Do not mix any fuel additives, so-called "flow improvers" (petrol and similar agents), into the diesel. This can result in considerable damage to parts of the engine or the exhaust system!

Engine compartment

Introduction

This chapter contains information on the following subjects:

Opening and closing the bonnet	146
Engine compartment overview	147
Radiator fan	147
Windscreen washer system	147

! WARNING

Injuries or scolding or risks of accident or fire may occur when working in the engine compartment. For this reason, it is essential to comply with the warning instructions outlined below and with the general applicable safety rules. The engine compartment of your car is a hazardous area!

! WARNING

Instructions before beginning work in the engine compartment

- Turn off the engine and withdraw the ignition key.
- Firmly apply the handbrake.
- If the vehicle is fitted with a manual gearbox, move the gearshift lever into Neutral, or if the vehicle is fitted with an automatic gearbox, move the selector lever into position **P**.
- Allow the engine to cool.
- Never open the bonnet if you can see steam or coolant escaping from the engine compartment – risk of scalding! Wait until no more steam or coolant is escaping.

! WARNING

Information for working in the engine compartment

- Keep all people, especially children, away from the engine compartment.
- Never touch the radiator fan while the engine is still warm. The fan might suddenly start running!
- Do not touch any hot engine parts – risk of burns!
- The coolant is harmful to health.
- Avoid contact with the coolant.
- Coolant vapours are harmful to health.
- Never open the end cover of the coolant expansion reservoir while the engine is still warm. The cooling system is pressurized!
- When opening the end cover of the coolant expansion reservoir, cover it with a cloth to protect your face, hands and arms from hot steam or hot coolant.
- If any coolant splashes into your eyes, immediately rinse out your eyes with clear water and contact a doctor as soon as possible.
- Always keep the coolant in the original container, safe from people who are not completely independent, especially children - there is a danger of poisoning!
- Consult a doctor immediately if coolant is swallowed.
- Never spill fluids on the hot engine. Such fluids (e.g. the antifreeze contained in the coolant) may ignite!

! WARNING

Information for working in the engine compartment with the engine running

- Pay particular attention to rotating engine parts (e.g. V-ribbed belt, generator, radiator fan) and the high-voltage ignition system – risk to life!
- Never touch the electric wiring on the ignition system.
- Avoid short circuits in the electrical system - particularly on the vehicle's battery.
- Always make sure that no jewellery, loose clothing or long hair can get caught in rotating engine parts – risk to life! Always remove any jewellery, tie back long hair and wear tight fitting clothing before completing any work.

! WARNING

Information for working on the fuel system or the electrical system

- Always disconnect the vehicle battery from the electrical system.

! WARNING (Continued)

- Do not smoke.
- Never work near open flames.
- Always have a functioning fire extinguisher nearby.

! WARNING

- Read and observe the information and warning instructions on the fluid containers.
- Keep the working fluids in sealed original containers and safe from people who are not completely independent, e.g. children.
- If you intend to work underneath the vehicle, you must secure the vehicle from rolling away and support it with suitable supporting blocks; the car jack is not sufficient – risk of injury!

! CAUTION

Always top up using the correct specification of fluids. This may result in major operating problems and also vehicle damage!

♻️ For the sake of the environment

In view of the requirements for the environmentally friendly disposal of fluids and the special tools and knowledge required for such work, we recommend that fluids be changed by a specialist garage.

i Note

- Please consult a specialist garage for any questions relating to fluids.
- Fluids with the proper specifications can be purchased from the ŠKODA Original Accessories or from the ŠKODA Genuine Parts ranges.

Opening and closing the bonnet

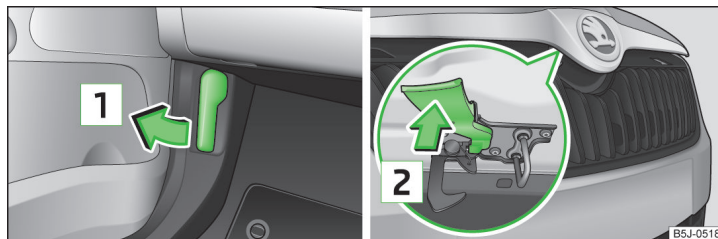

Fig. 132 Bonnet release lever/release lever

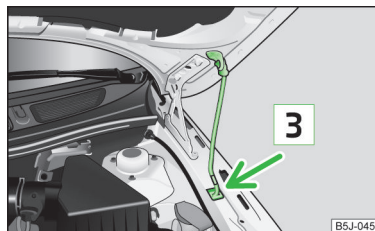

Fig. 133
Securing the bonnet

Read and observe **!** and **!** on page 145 first.

Open flap

- Pull the release lever under the dash panel in the direction of the arrow **1** » Fig. 132.

Before opening the bonnet, ensure that the arms of the windscreen wipers are correctly in place against the windscreen otherwise the paintwork could be damaged.

- Press the release lever in the direction of the arrow **2** to unlock the bonnet.
- Grab hold of the bonnet and lift.
- Take the bonnet prop out of its bracket and secure the opened bonnet by inserting the end of the prop in the opening **3** » Fig. 133 provided.

Close the flap

- Lift the bonnet slightly and unhook the bonnet support. Press the bonnet prop into the bracket provided.

➤ Let the bonnet drop into the lock carrier lock from a height of around 20 cm – do **not** push it in.

! WARNING

- Check that the bonnet is closed properly.
- If you notice that the lock is not properly engaged while driving, stop the vehicle immediately and close the bonnet – risk of accident!

! CAUTION

Never open the bonnet by the locking lever » Fig. 132.

Engine compartment overview

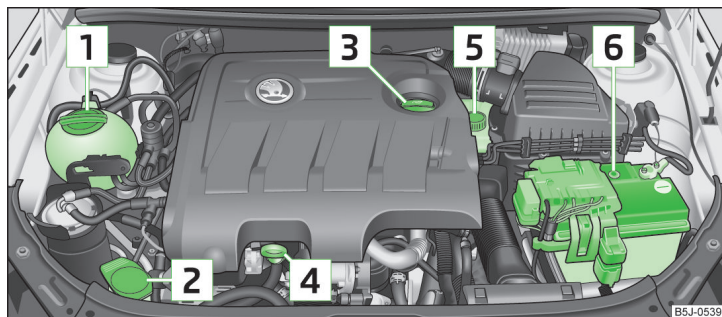

Fig. 134 Principle sketch: Engine compartment

📖 Read and observe **!** and **!** on page 145 first.

Explanation of graphic » Fig. 134

1	Coolant expansion reservoir	_____	151
2	Windscreen washer fluid reservoir	_____	147
3	Engine oil filler opening	_____	150
4	Engine oil dipstick	_____	149
5	Brake fluid reservoir	_____	152
6	Vehicle battery	_____	153

¹⁾ In some countries, 5.4 litres applies for both variants.

i Note

The location of the inspection points in the engine compartment of petrol and diesel engines is practically identical.

Radiator fan

📖 Read and observe **!** and **!** on page 145 first.

The radiator fan is powered by an electric motor. Operation is controlled according to the temperature of the coolant.

! WARNING

After switching off the ignition, the fan may intermittently continue to operate for approx. 10 minutes.

Windscreen washer system

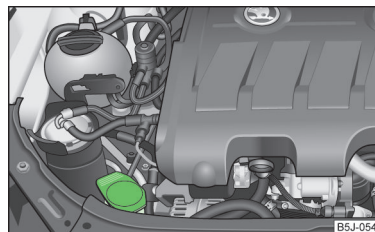

Fig. 135
Engine compartment: Wind-
screen washer fluid reservoir

📖 Read and observe **!** and **!** on page 145 first.

The windscreen washer fluid reservoir is located in the engine compartment » Fig. 135.

This contains the cleaning fluid for the windscreen or rear window and for the headlight cleaning system.

The capacity of the reservoir is about 3.5 litres or about 5.4 litres on vehicles that have a headlight cleaning system¹⁾.

Clear water is not sufficient to intensively clean the windscreen and headlights. We recommend using clean water together with a screen cleaner from the range of ŠKODA Original Accessories (**with antifreeze in winter**), which will remove any stubborn dirt.

The washing water should always be mixed with antifreeze in winter even if the vehicle has heated windscreen washer nozzles.

Under exceptional circumstances, methylated spirits can also be used if no screen cleaner with antifreeze is available. The concentration of methylated spirits must not be more than 15 %. The freeze protection at this concentration is sufficient only to -5 °C.

CAUTION

- Under no circumstances must radiator antifreeze or other additives be added to the windscreen washer fluid.
- If the vehicle is fitted with a headlight cleaning system, only cleaning products which do not attack the polycarbonate coating of the headlights must be added to the windscreen washer fluid.
- Do not remove the filter from the windscreen washer fluid reservoir when refilling, as this may cause contamination of the liquid transportation system, leading in turn to a windscreen washer system malfunction.

Engine oil

Introduction

This chapter contains information on the following subjects:

Specifications and capacity _____	148
Checking the oil level _____	149
Replenishing _____	150

The engine has been factory-filled with a high-grade oil that can be used throughout the year - except in extreme climate zones.



The engine oils are undergoing continuous further development. Thus the information stated in this Owner's Manual is only correct at the time of publication.

ŠKODA Service Partners are informed about the latest changes by the manufacturer. We therefore recommend that the oil change be completed by a ŠKODA Service Partner.

The specifications (VW standards) stated in the following can be indicated separately or together with other specifications on the bottle.

The oil capacities include oil filter change. Check the oil level when filling; do not over fill. The oil level must be between the markings » [page 149](#).

WARNING

- The engine compartment of your car is a hazardous area. The following warning instructions must be followed at all times when working in the engine compartment » [page 145](#).
- Do not continue your journey if for some reason it is not possible  to top up the engine oil under the prevailing conditions! Switch off the engine and seek assistance from a specialist garage.
-  Do not drive on if the oil level is above range **A** » [Fig. 136 on page 149](#). Switch off the engine and seek assistance from a specialist garage.

CAUTION

Do not pour any additives into the engine oil - risk of serious damage to the engine parts!

Note

- Before a long drive we recommend that you purchase and carry with you engine oil which complies with the specification for your vehicle.
- We recommend that you use oils from ŠKODA Original Accessories.
- If oil comes into contact with your skin, the affected area must be washed thoroughly.

Specifications and capacity

 **Read and observe  and  on page 148 first.**

Specifications and capacity (in l) for vehicles with flexible service intervals

Petrol engines	Specification	Capacity
1.2 litres/51 kW	VW 503 00, VW 504 00	2.8
1.2 l/63 kW TSI	VW 504 00	3.9
1.2l/77 kW TSI	VW 504 00	3.9
1.4 litres/63 kW	VW 503 00, VW 504 00	3.2

Diesel engines ^{a)}	Specification	Capacity
1.2 l/55 kW TDI CR	VW 507 00	4.3
1.6 litres/66 kW TDI CR DPF	VW 507 00	4.3
1.6 litres/77 kW TDI CR DPF	VW 507 00	4.3

^{a)} Engine oil VW 505 01 can optionally be used in diesel engines **without DPF**

Specifications and capacity (in l) for vehicles with fixed service intervals

Petrol engines	Specification	Capacity
1.2 litres/51 kW	VW 501 01, VW 502 00	2.8
1.2l/63 kW TSI	VW 502 00	3.9
1.2l/77 kW TSI	VW 502 00	3.9
1.4 l/63 kW	VW 501 01, VW 502 00	3.2
1.6 l/77 kW	VW 501 01, VW 502 00	3.6

If the oils specified above are not available, oils according to ACEA A2 or ACEA A3 can be used once for refilling.

Diesel engines ^{a)}	Specification	Capacity
1.2 l/55 kW TDI CR	VW 507 00	4.3
1.6 litres/66 kW TDI CR DPF	VW 507 00	4.3
1.6 litres/77 kW TDI CR DPF	VW 507 00	4.3

^{a)} Engine oil VW 505 01 can optionally be used in diesel engines **without DPF**

If the oils specified above are not available, oils according to ACEA B3 or ACEA B4 can be used once for refilling.

! CAUTION

Only the above-mentioned oils can be used on vehicles with flexible service intervals. We recommend always refilling with oil of the same specification since this will maintain the properties of the oil. In exceptional cases, a maximum of 0.5 l of specification VW 502 00 (only for petrol engines) or specification VW 505 01 (only for diesel engines) engine oil can be used to refill once. Other engine oils must not be used - there is risk of engine damage.

Checking the oil level

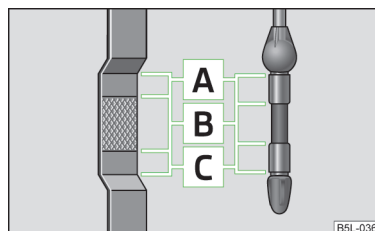

Fig. 136
Principle sketch: Dipstick

! **!** Read and observe **!** and **!** on page 148 first.

The dipstick indicates the engine oil level » Fig. 136.

Checking the oil level

Ensure that the vehicle is positioned on a level surface and the engine has reached its operating temperature.

➤ Switch off the engine.

Wait a few minutes until the engine oil flows back into the sump.

➤ Open the bonnet.

➤ Pull out the dipstick.

➤ Wipe the dipstick with a clean cloth and insert it again to the stop.

➤ Pull the dipstick out again and check the oil level.

Oil level within range **A**

No oil must be refilled.

Oil level within range **B**

Oil can be refilled. The oil level may lie in range **A**.

Oil level within range **C**

The engine **must** be topped up with oil so that the oil level at least reaches range **B**.

The engine burns some oil. The oil consumption may be as much as 0.5 l/1 000 km depending on your style of driving and the conditions under which you operate your vehicle. Consumption may be slightly higher than this during the first 5 000 kilometres.

The oil level must be checked at regular intervals. We recommend it be checked after each time you refuel or prior to making a long journey. ▶

We recommend maintaining the oil level within the range **A**, but not above, if the engine has been operating at high loads, for example, during a lengthy motorway trip during the summer months, towing a trailer or negotiating a high mountain pass.

The warning light in the instrument cluster will indicate whether the oil level is too low » page 40,  Engine oil. Check the oil level using the dipstick as soon as possible. Add oil accordingly.

CAUTION

The oil level must never be above the **A** range » Fig. 136 - there is a risk of damaging the exhaust system!

Replenishing

 Read and observe  and  on page 148 first.

- ▶ Check the oil level » page 149.
- ▶ Unscrew the cap of the engine oil filler opening » Fig. 134 on page 147.
- ▶ Replenish the oil in portions of 0.5 litres in accordance with the correct specifications » page 148, *Specifications and capacity*.
- ▶ Check the oil level » page 149.
- ▶ Carefully screw on the oil filler opening cap and push the dipstick in fully.

Coolant

Introduction

This chapter contains information on the following subjects:

Capacity _____	151
Checking the coolant level _____	151
Replenishing _____	151

The coolant consists of water with coolant additive. This mixture guarantees antifreeze protection, protects the cooling/heater system against corrosion and prevents lime formation.

Vehicles exported to countries with a **mild climate** are already factory-filled with a coolant which offers antifreeze protection down to about -25 °C. In these countries, the concentration of coolant additive should be at least 40%.

Vehicles exported to countries with a **cold climate** are already factory-filled with a coolant which offers antifreeze protection down to about -35 °C. In these countries, the concentration of coolant additive should be at least 50%.



If a higher concentration of antifreeze is required for climatic reasons, the concentration of coolant additive can be increased up to a maximum of 60% (antifreeze protection down to approx. -40 °C).

When refilling, only use the same antifreeze identified on the coolant expansion vessel » Fig. 137 on page 151.

WARNING

The engine compartment of your car is a hazardous area. The following warning instructions must be followed at all times when working in the engine compartment » page 145.

CAUTION

- Do not continue your journey if for some reason it is not possible  to top up the coolant under the prevailing conditions! Switch off the engine and seek assistance from a specialist garage.
- If the expansion tank is empty, do not top up with coolant. The system could ventilate - there is a risk of engine damage.  do not continue driving! Switch off the engine and seek assistance from a specialist garage.
- The concentration of coolant additive in the coolant must never be under 40%.
- Over 60% of coolant additive in the coolant reduces the antifreeze protection and cooling effect.
- A coolant additive that does not comply with the correct specifications can significantly reduce the corrosion protection.
- Any faults resulting from corrosion may cause a loss of coolant and can consequently result in major engine damage!
- Do not fill the coolant above the mark **A** » Fig. 137 on page 151.
- If a fault causes the engine to overheat, we recommend visiting a specialist garage, as otherwise serious engine damage may occur.
- Additional headlights and other attached components in front of the air inlet impair the cooling efficiency of the coolant.
- Never cover the radiator - there is a risk of the engine overheating.

Capacity

📖 Read and observe **!** and **!** on page 150 first.

Coolant capacity (in litres)¹⁾

Petrol engines	Capacity
1.2 l/51 kW	5.5
1.2l/63 kW TSI	7.7
1.2l/77 kW TSI	7.7
1.4 l/63 kW	5.5
1.6 l/77 kW	5.5

Diesel engines	Capacity
1.2 ltr./55 kW TDI CR DPF	6.6
1.6 litres/66 kW TDI CR DPF	8.4
1.6 litres/77 kW TDI CR DPF	8.4

Checking the coolant level

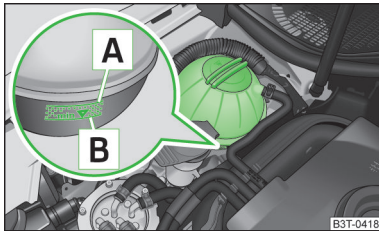

Fig. 137
Engine compartment: Coolant expansion reservoir

📖 Read and observe **!** and **!** on page 150 first.

The coolant expansion reservoir is located in the engine compartment » Fig. 137.

Explanation of graphic » Fig. 137

A Mark for the **maximum** permissible coolant level.

B Mark for the **lowest** permissible coolant level.

¹⁾ The coolant capacity is approximately 1 Litre greater on vehicles that are fitted with an auxiliary heater (auxiliary heating and ventilation).

The coolant level should be kept between the marks **A** and **B**.

If the coolant level is above the mark **A**, **no coolant may** be topped up.



If the coolant level is below the mark **B**, the coolant **must** be topped up.

Checking the level

- Switch off the engine.
- Open the bonnet.
- Check the level of coolant at the coolant expansion vessel » Fig. 137.

Check the coolant level only when the engine is cold.

If the engine is warm, the test result may be inaccurate. The level can also be above the mark **A** » Fig. 137.

If the coolant level in the coolant expansion tank is too low, this is indicated by the warning light  lighting up in the instrument cluster » page 41,   *Coolant*. We still recommend inspecting the coolant level directly at the reservoir from time to time.

Loss of coolant

A loss of coolant is first and foremost an **indication of a leak** in the system. Do not merely top up the coolant. Have the cooling system checked by a specialist garage.

Replenishing

📖 Read and observe **!** and **!** on page 150 first.

The coolant expansion tank must always contain a small amount of coolant » page 150, **!** in section *Introduction*.

- Switch off the engine.
- Allow the engine to cool.
- Place a cloth over the cap of the coolant expansion tank and **carefully** unscrew the cap.
- Replenish the coolant.
- Turn the cap until it clicks into place.

! CAUTION

- Only top up with new coolant.
- Do not use an alternative additive if the specified coolant is not available. In this case, use only water and have the correct mixing ratio of water and coolant additive restored by a specialist garage as soon as possible.

Brake fluid

Introduction

This chapter contains information on the following subjects:

Checking the brake fluid level	152
Changing	152

! WARNING

- The engine compartment of your car is a hazardous area. The following warning instructions must be followed at all times when working in the engine compartment » [page 145](#).
- 🚫 Do not continue your journey if the fluid level has fallen below the MIN marking » [Fig. 138 on page 152](#) - there is a risk of an accident. Seek help from a specialist garage.
- Do not use used brake fluid - the function of the brake system may be impaired - risk of accident!

! CAUTION

Brake fluid damages the paintwork of the vehicle.

i Note

- The brake fluid is changed as part of a compulsory inspection service.
- We recommend using brake fluids from the ŠKODA Original Accessories range.

Checking the brake fluid level

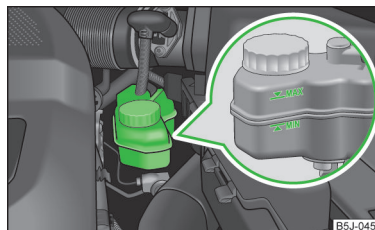

Fig. 138
Engine compartment: Brake fluid reservoir

📖 Read and observe ! and ! on page 152 first.



The brake fluid reservoir is located in the engine compartment » [Fig. 138](#).

- Switch off the engine.
- Open the bonnet.
- Check the level of brake fluid in the reservoir » [Fig. 138](#).

The level must be between the "MIN" and "MAX" markings.

A slight drop in the fluid level results in operation due to normal wear and tear and the automatic adjustment of the brake pads.

There may be an indication of a leak in the brake system, however, if the fluid level drops significantly within a short time or if it drops below the "MIN" marking.

If the brake fluid level is too low, this is indicated by the indicator light  » [page 40](#),  Brake system lighting up in the instrument cluster.

Changing

📖 Read and observe ! and ! on page 152 first.

Brake fluid absorbs moisture. Over time it therefore absorbs moisture from the environment.

Excessive water in the brake fluid may be the cause of corrosion in the brake system.

The water content lowers the boiling point of the brake fluid. ▶

The brake fluid must comply with the following standards or specifications:

- VW 50114;
- FMVSS 116 DOT4.





Vehicle battery

Introduction

This chapter contains information on the following subjects:

Open cover _____	154
Checking the battery electrolyte level _____	154
Charging _____	155
Replacing _____	155
Disconnecting or reconnecting _____	155
Automatic load deactivation _____	156

Warning symbols on the vehicle battery

Symbol	Meaning
	Always wear eye protection.
	Battery acid is severely caustic. Always wear gloves and eye protection.
	Keep fire, sparks, open flames and lit cigarettes well clear of the vehicle battery.
	When charging the vehicle battery, a highly explosive gas mixture is produced.
	Keep children away from the vehicle battery.

! WARNING

There is risk of injuries, poisoning, chemical burns, explosions or fire when working on the battery and on the electrical system. It is essential to comply with the generally applicable rules of safety as well as the warning instructions outlined below.

- Keep the vehicle battery away from people who are not completely independent, especially children.

! WARNING (Continued)

- Do not tilt the battery otherwise battery electrolyte may flow out of the battery vent openings. Protect your eyes by wearing safety goggles or a face shield – risk of blindness!
- Always wear protective gloves, eye and skin protection when handling the vehicle battery.
- The battery acid is strongly corrosive and must, therefore, be handled with the greatest of care.
- Corrosive fumes in the air irritate the air passages and lead to conjunctivitis and inflammation of the air passages in the lungs.
- Battery acid corrodes dental enamel and, if it comes into contact with the skin, causes deep wounds that take a long time to heal. Repeated contact with diluted acids causes skin diseases (inflammations, ulcers, skin cracks).
- If any battery acid comes into contact with your eyes, rinse the affected eye immediately with clean water for several minutes and consult a doctor immediately!
- Splashes of acid on your skin or clothes should be neutralised as soon as possible using soap suds and then rinsed with plenty of water. If you swallow battery acid, consult a doctor immediately!

! WARNING

- It is prohibited to work with naked flames or lights.
- It is prohibited to smoke or carry out any activities that produce sparks.
- Never use a damaged vehicle battery – risk of explosion!
- Never charge a frozen or thawed vehicle battery – risk of explosion and chemical burns!
- Replace a frozen vehicle battery.
- Never jump-start vehicle batteries with insufficient acid levels – risk of explosion and chemical burns.

! WARNING

- When you charge a battery, hydrogen is released, and a highly explosive gas mixture is also produced. An explosion can be caused through sparking over during unclamping or loosening of the cable plug while the ignition is on.
- Creating a bridge between the poles on the battery (e.g. with a metal object or cable) creates a short circuit - risk of melting the lead bars, and risk of explosion, battery fire and acid splashes.

! WARNING (Continued)

- Avoid creating sparks when working with cables and electrical devices. Strong sparking represents a risk of injury.
- Before carrying out any work on the electrical system, switch off the engine, the ignition and all electrical components and disconnect the negative terminal (-) on the battery.

! CAUTION

Improper handling of the battery can lead to damage. We recommend having all work on the vehicle battery carried out by a specialist garage.

! CAUTION

- The vehicle battery must only be disconnected if the ignition is switched off, otherwise the vehicle's electrical system (electronic components) can be damaged. When disconnecting the battery from the electrical system, first of all disconnect the negative terminal (-) of the battery, and then the positive terminal (+).
- When connecting the battery to the electrical system, first of all connect the positive terminal (+) of the battery, and then the negative terminal (-). Under no circumstances must the battery cables be connected incorrectly - risk of a cable fire.
- Ensure that battery acid does not come into contact with the bodywork - risk of damage to the paintwork.
- Do not place the battery in direct daylight in order to protect the vehicle battery housing from the effects of ultra-violet light.
- If the vehicle has not been driven for more than 3 to 4 weeks, the battery will discharge. This is because certain electrical components consume electricity (e. g. control units) also in idle state. Prevent the battery from discharging by disconnecting the battery's negative terminal (-) or continuously charging the battery with a very low charging current.
- If the vehicle is frequently used for making short trips, the vehicle battery will not have time to charge up sufficiently and may discharge.

♻️ For the sake of the environment

A vehicle battery that has been removed is a special type of hazardous waste. These must be disposed of in accordance with national legal regulations.

i Note

You should replace batteries older than 5 years.

Open cover

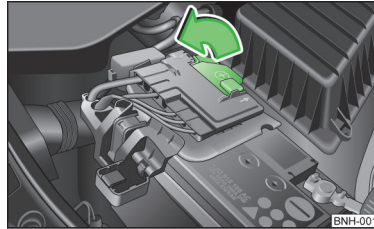

Fig. 139
Plastic cover of the vehicle battery

📖 Read and observe **!** and **!** on page 153 first.

The battery is located in the engine compartment below a plastic box.

➤ Open the cover in the direction of the arrow » Fig. 139.

The installation of the battery cover on the positive terminal side takes place in the reverse order.

Checking the battery electrolyte level

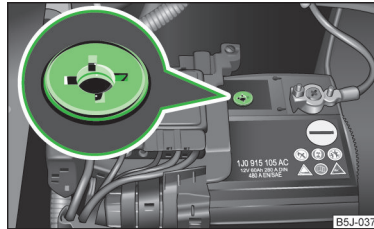

Fig. 140
Vehicle battery: Electrolyte level indicator

📖 Read and observe **!** and **!** on page 153 first.

On vehicles with a vehicle battery fitted with a colour indicator, » Fig. 140 the colouring of the display can indicate the acidic level.

Air bubbles can influence the colour of the indicator. For this reason carefully knock on the indicator before carrying out the check.

➤ Black colour - electrolyte level is correct.

➤ Colourless or light yellow colour - electrolyte level too low, the battery must be replaced.

Vehicles with a START-STOP system are fitted with a battery control unit for checking the energy level for the recurring engine start.

We recommend that you have the acid level checked regularly by a specialist garage, especially in the following cases.

- High external temperatures.
- Longer day trips.
- After each charge.

Winter time

The vehicle battery only has some of its starting power at low temperatures. **A discharged vehicle battery may freeze at temperatures just below 0 °C.**

We therefore recommend that you have the battery checked and, if necessary, recharged by a specialist garage before the start of the winter.

! CAUTION

For technical reasons, on vehicles with the description "AGM", the electrolyte level cannot be checked.

i Note

The battery acid level is also checked regularly by a specialist garage as part of the inspection service.

Charging

📖 Read and observe ! and ! on page 153 first.

A properly charged vehicle battery is essential for reliably starting the engine.

- Switch off the ignition and all of the electrical components.
- Disconnect both battery cables ("negative" first, then "positive") only when "rapid charging" the battery.
- Attach the terminal clamps of the charger to the battery terminals (red = "positive", black = "negative").
- Plug the mains cable of the charger into the power socket and switch the charger on.
- Once charging is complete: Switch off the charger and remove the mains cable from the power socket.
- Only then disconnect the charger's terminal clamps.
- Reconnect the cables to the battery (first "positive", then "negative").

It is not necessary to disconnect the battery cables if you are recharging the vehicle battery using low amperages (for example from a mini-charger). **Refer to the charger manufacturer's instructions.**

A charging current of 0.1 multiple of the total vehicle battery capacity (or lower) must be used until full charging is achieved.

Both cables must be disconnected before charging the battery with high amperages, known as "**rapid charging**".

The vent plugs of the vehicle battery should not be opened for charging.

! WARNING

"Quick-charging" the vehicle battery is **dangerous** and requires a special charger and specialist knowledge.

! CAUTION

On vehicles with the START/STOP system, the pole terminal of the charger must not be connected directly to the negative terminal of the vehicle battery, but only to the engine earth » [page 173, Jump-starting in vehicles with the START-STOP system.](#)

i Note

We therefore recommend that vehicle batteries be rapid charged by a specialist garage.

Replacing

📖 Read and observe ! and ! on page 153 first.

The new vehicle battery must have the same capacity, voltage, current and size as the original battery. Suitable vehicle battery types can be purchased from a specialist garage.

We recommend having the battery replaced by a specialist garage, where the new vehicle battery will be installed properly and the original battery will be disposed of in accordance with national regulations.

Disconnecting or reconnecting

📖 Read and observe ! and ! on page 153 first.

The following functions are initially deactivated or are no longer able to operate faultlessly after the vehicle battery has been disconnected and reconnected. ▶

Operation	Operating measure
Electrical power window (operational faults)	» page 57
Enter the radio/navigation system code number	» <i>User manual of the radio</i> or » <i>user manual of the navigation system</i>
Setting the clock	» page 32
Data in the multifunction display are deleted.	» page 33

i Note

We recommend having the vehicle checked by a specialist garage in order to ensure full functionality of all electrical systems.

Automatic load deactivation

 **Read and observe  and  on page 153 first.**

The vehicle voltage control unit automatically prevents the battery from discharging when the battery is put under high levels of strain. This may be noticed from the following.

- ▶ The idling speed is raised to allow the generator to deliver more electricity to the electrical system.
- ▶ Where necessary, large convenience consumers such as seat heaters and rear window heaters have their power limited or are shut off completely in the event of an emergency.

! CAUTION

- Despite such intervention by the vehicle electric system management, the vehicle battery may be drained. For example, when the ignition is switched on a long time with the engine turned off or the side or parking lights are turned on during longer parking.
- Consumers that are supplied via a 12-V power socket can cause the vehicle battery to discharge when the ignition is switched off.

i Note

Driving comfort is not impaired by consumers being deactivated. The driver is often not aware of it having taken place.

Wheels

Tyres and wheel rims

Introduction

This chapter contains information on the following subjects:

Service life of tyres	157
Unidirectional tyres	158
Spare and temporary spare wheel	159
Full wheel trim	159
Wheel bolts	160

Only use tyres or wheel rims that have been approved by ŠKODA for your model of vehicle.

! WARNING

The national legal regulations must be observed for the use of tyres.

! WARNING

Instructions for the use of tyres

- For the first 500 km, new tyres do not yet provide optimum grip, and appropriate care should therefore be taken when driving – risk of accident!
- For reasons of driving safety, do not replace tyres individually.
- Never exceed the maximum permissible **load bearing capacity** of mounted tyres.
- Never exceed the maximum permissible **speed** for the mounted tyres.
- An incorrect wheel alignment at the front or rear impairs handling.
- Unusual vibrations or pulling of the vehicle to one side could be a sign of tyre damage. If there is any doubt that a wheel is damaged, immediately reduce your speed and stop! If no external damage is evident, drive slowly and carefully to the nearest specialist garage to have the vehicle checked.

! WARNING

Information regarding tyre damage or wear

- Never use tyres if you do not know anything about the condition and age.
- Never drive with damaged tyres – there is the risk of an accident occurring.

In vehicles with tyre pressure monitoring, tyre pressure values are to be stored » [page 125](#).

With greater additional load, adjust the tyre inflation pressure accordingly.

Driving style

Fast cornering, sharp acceleration and braking increase the wear of your tyres.

Balancing wheels

The wheels of a new vehicle are balanced. When driving, however, there are a range of factors that may result in an imbalance. This may become apparent by "vibration" in the steering. If this is the case, have the wheels checked by a specialist garage.

Have the wheels likewise rebalanced after replacing the tyres.

Setting the vehicle geometry

Incorrect wheel alignment at the front or rear leads to excess wear on the tyres and impairs driving safety. With a distinctive tyre wear, we recommend that you check the setting of the vehicle geometry in a specialist workshop.

Tyre damage

We recommend checking your tyres and wheel rims for damage (punctures, cuts, splits and bulges, etc.) on a regular basis. Remove foreign bodies (e.g. small stones) from the tyre tread immediately.

Drive over kerbs and other such obstacles slowly and at right angles wherever possible in order to avoid damage to tyres and wheel trims.

Immediately replace damaged wheel rims or tyres.

Replacing wheels

For uniform wear on all tyres, we recommend that you change the wheels every 10 000 km according to schedule » [Fig. 142](#). You will then obtain approximately the same life for all the tyres.

After a wheel has been replaced, the tyre pressure has to be adjusted.

In vehicles with tyre pressure monitoring, tyre pressure values are to be saved » [page 125](#).

Storing tyres

Identify disassembled tyres so that the previous direction of rotation can be maintained if the tyres are reassembled.

Always store wheels or tyres in a cool, dry place that is as dark as possible. Tyres which are not fixed to a wheel trim should be stored upright.

Wear indicators

The base of the tread of the tyres contains has a 1.6 mm high wear indicator » [Fig. 141](#) - [A](#). In some countries, different tyre wear rates may apply.

Markings on the walls of the tyres through the letters "TWI", triangular symbols or other symbols identify the position of the wear indicators.

Tyre age

Tyres age and lose their original characteristics, even if they are not being used. The service life of the tyres is 6 years. Therefore, we recommend not using tyres that are older than 6 years.

Wheel bolts

Wheels and wheel bolts are matched to each other in terms of design. We recommend that you use wheel rims, tyres, full wheel trims and snow chains from SKODA Original Accessories.

Note

In some countries, the vehicles have a sticker with tyre inflation pressure values without pictograms.

Unidirectional tyres

 **Read and observe  and  on page 156 first.**

The direction of rotation of the tyres is marked by **arrows on the wall of the tyre**.

The indicated direction of rotation must be adhered to in order to ensure the optimal characteristics of these tyres.

These characteristics mainly relate to the following:

- Increased driving stability.
- Reduced risk of aquaplaning.
- Reduced tyre noise and tyre wear.

Spare and temporary spare wheel

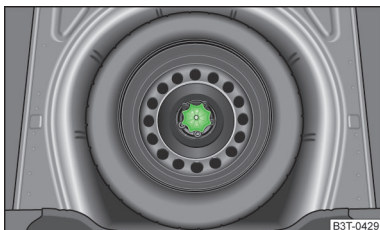

Fig. 143
Fixing the spare or temporary
spare wheel

📖 Read and observe **!** and **!** on page 156 first.

The spare wheel is located in a well under the floor covering in the boot and is fixed in place with a special bolt » Fig. 143.

Taking the wheel out

- › Open the tailgate.
- › Lift up the floor in the luggage compartment.
- › Remove the box with the tool kit.
- › Unscrew the nut » Fig. 143 anticlockwise.
- › Take out the wheel.

Stowing the wheel

- › Place the wheel into the spare wheel well with the wheel rim pointing downward.
- › Screw on the nut » Fig. 143 clockwise until the wheel is safely secured.
- › Replace the box with the tool kit into the spare wheel and secure it with the tape.
- › Fold back the floor in the luggage compartment.
- › Close the boot lid.

Fit a wheel in the appropriate dimensions and design as soon as possible.

If the dimensions or design of the spare wheel differ from the tyres fitted to the vehicle (e.g. winter tyres or low-profile tyres), it must only be used briefly in the event of a puncture and if an appropriately cautious style of driving is adopted » **!**.

Temporary spare wheel

A warning label is displayed on the rim of the temporary spare wheel.

Please note the following if you intend to use the temporary spare wheel.

- › The warning label must not be covered after installing the wheel.
- › Be particularly observant when driving.
- › The temporary spare wheel is inflated to the maximum inflation pressure for the vehicle » Fig. 141 on page 157.
- › Only use this temporary spare wheel to reach the nearest specialist garage, since it is not intended for permanent use.

! WARNING

- Never drive with more than one temporary spare wheel mounted!
- Only use the temporary spare wheel when absolutely necessary.
- Never use the temporary spare wheel if it is damaged.
- If the dimensions or design of the temporary spare wheel differ from the fitted tyres, never drive faster than 80 km/h (or 50 mph).
- Avoid accelerating at full throttle, sharp braking and fast cornering.
- The snow chains cannot be used on the temporary spare wheel.
- Observe the instructions on the warning sticker on the temporary spare wheel.

Full wheel trim

📖 Read and observe **!** and **!** on page 156 first.

Before removing the wheel bolts, remove the wheel cover.

Pulling off

- › Hook the clamp found in the vehicle tool kit » page 166 into the reinforced edge of the wheel trim.
- › Push the wheel wrench through the clamp, support on the tyre and pull off the wheel trim.

Fitting

- › Press the wheel trim onto the wheel rim at the designated valve opening.
- › Then press the trim into the wheel rim until its entire circumference locks correctly in place.

! CAUTION

- Use the pressure of your hand only, do not strike the full wheel trim! The cover could be damaged.
- When using the anti-theft wheel bolt, ensure that it is in the hole in the valve area.
- If wheel trims are fitted, an adequate flow of air must be assured in order to cool the brake system.

i Note

We recommend that you use child seats from ŠKODA Original Accessories.

Wheel bolts



Fig. 144
Remove the cap

📖 Read and observe **i** and **!** on page 156 first.

Before removing the wheel bolts, remove the covering caps.

Pulling off

- Push the extraction pliers » page 166 sufficiently far onto the cap until the inner catches of the pliers are positioned at the collar of the cap.
- Remove the cap in the direction of the arrow » Fig. 144.

Fitting

- Push the cap onto the wheel bolt up to the stop.

Approved tyre / rim combinations

📖 Introduction

This chapter contains information on the following subjects:

Explanation of the tyre labelling	160
Roomster	161

Roomster GreenLine	161
Roomster Green tec	162
Roomster Scout	162
Roomster Noire	162
Roomster N1	162
Roomster Praktik	163

This chapter contains manufacturer-approved tyre / rim combinations, divided into modules according to the individual model variants.

Shared combinations are initially to be sought for the model variant (Roomster GreenLine, Roomster Scout and such like) and then according to the engine size of your vehicle.

If the model variant of your vehicle cannot be found in the discrete module, then the approved combinations are to be found according to the engine size of your vehicle in module » page 161, *Roomster*.

Only use radial tyres of the same type, size (rolling circumference) and tread pattern on one axle on all four wheels.

When mounting new tires the tires have to be replaced axle by axle.

The information listed in the table corresponds to the information available at the time of going to press.

The approved tyre / rim combinations for your car are given on the sales and technical vehicle documentation.

Explanation of the tyre labelling

Explanation of tyre markings

For example, **185/65 R 14 86 T** means:

185	Tyre width in mm
65	Height/width ratio in %
R	Code letter for the type of tyre - Radial
14	Diameter of wheel in inches
86	Load index
T	Speed symbol

The **date of manufacture** is stated on the tyre wall (possibly on the **inside**).

For example, **DOT ... 11 14...** means, for example, that the tyre was manufactured in the 11th week of the year 2014. ▶

The marking **M+S** means that the associated tyre is suitable for winter use.

Load index

The load index indicates the maximum permissible load for each individual tyre.

Load index	83	85	86	87	91	92	93
Load (In kg)	487	515	530	545	615	630	650

Speed symbol

The maximum speed symbol indicates the maximum permissible vehicle speed with fitted tyres in each category.

Speed icon	R	S	T	U	H	V	W
Maximum speed (in km/h)	170	180	190	200	210	240	270

! CAUTION

The information about load index and speed symbol can be found in the vehicle sales and technical documentation.

Roomster

Motorisation	Tyre size	Load index	Speed icon
1.2 l/51 kW	175/70 R14	84	T
	185/65 R14	86	T
	195/55 R15	85	H
	205/45 R16	83	H
	205/40 R17	84	W
1.2 l/63 kW TSI	175/70 R14	84	T
	185/65 R14	86	T
	195/55 R15	85	H
	205/45 R16	83	H
	205/40 R17	84	W

Motorisation	Tyre size	Load index	Speed icon	
1.2 l/77 kW TSI	185/60 R15	84	H	
	195/55 R15	85	H	
	205/45 R16	83	H	
	205/40 R17	84	W	
1.4 litres/63 kW	175/70 R14	84	T	
	185/65 R14	86	T	
	195/55 R15	85	H	
	205/45 R16	83	H	
205/40 R17	84	W		
	1.6 l/77 kW	195/55 R15	85	H
		205/45 R16	83	W
1.2 l/55 kW TDI CR	185/60 R15	84	T	
	195/55 R15	85	H	
	205/45 R16	83	H	
	205/40 R17	84	W	
1.6 l/66 kW TDI CR	185/60 R15	84	T	
	195/55 R15	85	H	
	205/45 R16	83	H	
	205/40 R17	84	W	
1.6 l/77 kW TDI CR	185/60 R15	84	H	
	195/55 R15	85	H	
	205/45 R16	83	H	
	205/40 R17	84	W	

Roomster GreenLine

Motorisation	Tyre size	Load index	Speed icon
1.2 l/55 kW TDI CR	185/60 R15	84	T

Roomster Green tec

Motorisation	Tyre size	Load index	Speed icon
1.2 l/63, 77 kW TSI	185/60 R15	84	H

Roomster Scout

Motorisation	Tyre size	Load index	Speed icon
1.2 ltr./63 kW TSI	185/60 R15	84	T
	195/55 R15	85	H
	205/45 R16	83	H
	205/40 R17	84	W
1.2 l/77 kW TSI	185/60 R15	84	H
	195/55 R15	85	H
	205/45 R16	83	H
	205/40 R17	84	W
1.4 l/63 kW	185/60 R15	84	T
	195/55 R15	85	H
	205/45 R16	83	H
	205/40 R17	84	W
1.6 l/77 kW	185/60 R15	84	H
	195/55 R15	85	H
	205/45 R16	83	H
	205/40 R17	84	W
1.2 l/55 kW TDI CR	185/60 R15	84	T
	195/55 R15	85	H
	205/45 R16	83	H
	205/40 R17	84	W
1.6 l/66, 77 kW TDI CR	185/60 R15	84	H
	195/55 R15	85	H
	205/45 R16	83	H
	205/40 R17	84	W

Roomster Noire

Noire

Motorisation	Tyre size	Load index	Speed icon
1.2 l/51, 63, 77 kW TSI	205/45 R16	83	H
	205/40 R17	84	W
1.2 l/55 kW TDI	205/45 R16	83	H
	205/40 R17	84	W
1.4 l/63 kW	205/45 R16	83	H
	205/40 R17	84	W
1.6 l/55, 66 kW TDI CR	205/45 R16	83	H
	205/40 R17	84	W

Noire Green tec

Motorisation	Tyre size	Load index	Speed icon
1.2 l/63, 77 kW TSI	185/60 R15	84	H

Roomster N1

Motorisation	Tyre size	Load index	Speed icon
1.2 l/51 kW	185/60 R15	84	T
	195/55 R15	85	H
	205/45 R16	87	T
	205/40 R17	84	W
1.2 l/63 kW TSI	185/60 R15	84	T
	195/55 R15	85	H
	205/45 R16	87	H
	205/40 R17	84	W
1.2l/77 kW TSI	185/60 R15	84	H
	195/55 R15	85	H
	205/45 R16	87	H
	205/40 R17	84	W

Motorisation	Tyre size	Load index	Speed icon
1.4 l/63 kW	185/60 R15	84	T
	195/55 R15	85	H
	205/45 R16	87	H
	205/40 R17	84	W
1.6 litres/77 kW	195/55 R15	85	H
	205/45 R16	87	H
1.2 l/55 kW TDI CR	185/60 R15	84	T
	195/55 R15	85	H
	205/45 R16	87	H
1.6 l/66 kW TDI CR	185/60 R15	84	H
	195/55 R15	85	H
	205/45 R16	87	H
	205/40 R17	84	W
1.6 l/77 kW TDI CR	185/60 R15	84	T
	195/55 R15	85	H
	205/45 R16	87	H
	205/40 R17	84	W

Roomster Praktik

Practice - vehicles with front brakes for 14 inch rims

Motorisation	Tyre size	Load index	Speed icon
1.2 litres/51 kW	175/70 R14	84	T
	185/60 R15	84	T
	185/65 R14	86	T
	195/55 R15	85	H
1.2 ltr./63 kW TSI	175/70 R14	84	T
	185/65 R14	86	T
	195/55 R15	85	H

Motorisation	Tyre size	Load index	Speed icon
1.4 litres/63 kW	175/70 R14	84	T
	185/60 R15	84	T
	185/65 R14	86	T
	195/55 R15	85	H

Praktik - vehicles with front brakes for 15 inch rims

Motorisation	Tyre size	Load index	Speed icon
1.2 litres/51 kW	185/60 R15	84	T
	195/55 R15	85	H
1.2 ltr./63 kW TSI	185/60 R15	84	T
	195/55 R15	85	H
1.4 litres/63 kW	185/60 R15	84	T
	195/55 R15	85	H
1.2 l/55 kW TDI CR	185/60 R15	84	T
	195/55 R15	85	H
1.6 l/66 kW TDI CR	185/60 R15	84	H
	195/55 R15	85	H

i Note

The information about whether the vehicle is equipped with front brakes for 14-inch or 15-inch wheels is to be gathered from the vehicle's technical documentation or an enquiry be made of a ŠKODA Partner.

Winter operation

Introduction

This chapter contains information on the following subjects:

Winter tyres	_____	163
Snow chains	_____	164

Winter tyres

Summer tyres have less grip on ice, snow and at temperatures below 7 °C. ▶

Fitting winter tyres will significantly improve the handling of your vehicle when driving in wintry road conditions.

To get best possible handling, winter tyres must be fitted to all four wheels. The minimum tread depth must be 4 mm.

Winter tyres (marked with **M+S** and a peak/snowflake symbol) of a lower speed category can be used provided that the permissible maximum speed of these tyres is not exceeded even if the possible maximum speed of the vehicle is higher.

Only use those tyres or wheel rims which have been approved by ŠKODA for your model of vehicle.

The speed limit for winter tyres can be set in the MAXI DOT display in the **Winter tyres** menu item » [page 38](#).

For the sake of the environment

Re-fit the summer tyres at an appropriate time as they provide better handling properties, a shorter braking distance, less tyre noise, and reduced tyre wear on roads which are free of snow and ice as well as at temperatures above 7 °C. The fuel consumption is also lower.

Snow chains

When driving in wintry road conditions, snow chains improve not only traction, but also the braking performance.

Snow chains must only be mounted on the front wheels.

For technical reasons, it is only permissible to fit snow chains with the following wheel/tyre combinations.

Wheel size	Depth D	Tyre size
5J x 14	35 mm	175/70 R14
6J x 14	37 mm	185/65 R14
6J x 15	43 mm	185/55 R15

Remove the full wheel trims before installing the snow chains » [page 159](#).

Only fit snow chains with links and locks not larger than **12 mm**.

The chains are to be removed when driving on snow-free paths. They would otherwise cause loss of performance and damage the tyres.

Do-it-yourself

Emergency equipment and self-help

Emergency equipment

Introduction

This chapter contains information on the following subjects:

First aid kit and warning triangle	165
fire extinguisher	165
Vehicle tool kit	166

First aid kit and warning triangle

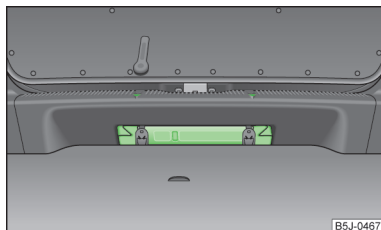

Fig. 145
Placing of the warning triangle

A warning triangle with the maximum dimensions 39 x 68 x 450 mm can be attached to the trim panel of the rear wall with rubber straps » Fig. 145.

! WARNING

The first-aid kit and warning triangle must always be secured safely so that they do not come loose when making an emergency braking or in a vehicle collision which could cause injuries to occupants.

i Note

- Pay attention to the expiration date of the first-aid kit.
- We recommend using a first-aid kit from ŠKODA Original Accessories, which are available from a ŠKODA Partner.

fire extinguisher

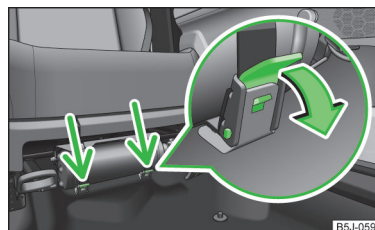

Fig. 146
Fire extinguisher

The fire extinguisher is attached by two straps in a bracket under the driver's seat.

Removing/attaching

- Loosen the two straps by pulling the buckles in the direction of the arrow » Fig. 146.
- Remove the fire extinguisher.
- For mounting, fit the fire extinguisher back into the holder and secure it with straps.

Please read carefully the instructions which are attached to the fire extinguisher.

The fire extinguisher must be checked by an authorised person once a year. National legal requirements must be observed.

! WARNING

The fire extinguisher must always be secured safely so that they do not come loose when making an emergency braking or in a vehicle collision which could cause injuries to occupants.

i Note

- The fire extinguisher must comply with national legal requirements.
- Pay attention to the expiration date of the fire extinguisher. Proper functioning of the fire extinguisher is not assured once it has passed its expiry date.
- The fire extinguisher is part of the scope of delivery in certain countries only.

Vehicle tool kit

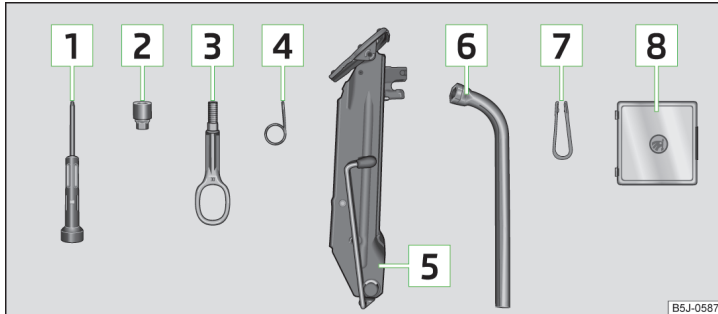

Fig. 147 Vehicle tool kit

The vehicle tool kit is housed in a box in the spare wheel or in the compartment for the spare wheel underneath the floor covering in the luggage compartment. The box is attached with a strap on the spare wheel.

Depending on the equipment, not all the components listed in the on-board tool kit have to be contained in it.

- 1 Screwdriver
- 2 Adapter for anti-theft wheel bolts
- 3 Towing eye
- 4 Clamps for removing the wheel trims
- 5 Depending upon vehicle equipment: Jack with sign / puncture repair kit
- 6 Wheel wrench
- 7 Extraction pliers for wheel bolt caps
- 8 Replacement bulb set

! WARNING

The factory-supplied lifting jack is only intended for your model of vehicle. Under no circumstances attempt to lift heavier vehicles or other loads.

! CAUTION

- Screw the jack back into the starting position before storing in the box with the tool kit.
- Ensure that the vehicle tool kit is safely secured in the boot.
- Ensure that the box is always secured with the strap.

i Note

The declaration of conformity is included with the jack or the log folder.

Changing a wheel

Introduction

This chapter contains information on the following subjects:

Preliminary work	167
Changing a wheel	167
Follow-up work	167
Loosening/tightening wheel bolts	168
Raising the vehicle	168
Anti-theft wheel bolts	169

! WARNING

- If you are in flowing traffic, switch on the hazard warning light system and set up the warning triangle at the prescribed distance! The national legal requirements must be observed.
- Park the vehicle as far away as possible from the flow of traffic. Park on as flat and firm a surface as possible.
- The following instructions must be followed if the vehicle is subsequently fitted with tyres or rims that differ from the factory-fitted ones >> [page 160](#), *Explanation of the tyre labelling*.

! WARNING

Information on the wheel bolts

- The wheel bolts must be clean and must turn easily. Never treat them with grease or oil.
- The prescribed tightening torque of the wheel bolts for steel and light alloy wheels is 120 Nm.

! WARNING (Continued)

- If the wheel bolts are tightened to a too low tightening torque, the rim can come loose when the car is moving. A tightening torque which is too high can damage the bolts and threads and this can result in permanent deformation of the contact surfaces on the rim.
- In case of incorrect treatment of the wheel bolts, the wheel can loosen when the car is moving.

i Note

The national legal requirements must be observed when changing a wheel.

Preliminary work

 Read and observe **!** on page 166 first.

Before changing the wheel, the following work must be carried out.

- Have **all the occupants get out**. The passengers should not stand on the road (instead they should remain behind a crash barrier, for instance) while the wheel is being changed.
- Switch off the engine.
- Engage the **1st gear** or place the selector lever of the automatic transmission in the **P-position**.
- Apply the **handbrake** firmly.
- Uncouple a trailer.
- Remove the **vehicle tool kit** » page 166 and the **spare wheel** » page 159, *Spare and temporary spare wheel* from the boot.

Changing a wheel

 Read and observe **!** on page 166 first.

When changing a wheel, the following instructions must be followed.

- Remove the full wheel trim or the caps of the wheel bolts.
- First of all slacken the anti-theft wheel bolt and then the other wheel bolts.
- Jack up the vehicle until the wheel that needs changing is clear of the ground.
- Unscrew the wheel bolts and place them on a clean surface (cloth, paper, etc.).
- Remove the wheel carefully.
- Attach the spare wheel and slightly screw on the wheel bolts.
- Lower the vehicle.

- Tighten the opposite wheel bolts alternately (cross-wise) with the wheel wrench. Tighten the anti-theft wheel bolt last.
- Replace the wheel trim or the caps.

! WARNING

- If it is established when changing a wheel that the wheel bolts are corroded and difficult to move, then these must be replaced.
- When fitting unidirectional tyres, ensure that the direction of rotation is correct » page 156.

Follow-up work

 Read and observe **!** on page 166 first.

After changing the wheel, the following work must be carried out.

- Stow and attach the replaced wheel in the spare wheel well using a special screw » page 159, *Spare and temporary spare wheel*.
- Stow the tool kit in the space provided and secure using the strap.
- **Check the tyre pressure** on the installed spare wheel as soon as possible.
- Have the **tightening torque** of the wheel bolts **checked** with a torque wrench as soon as possible.

After changing the wheel, the tyre pressure should be adjusted. In vehicles with tyre pressure monitoring, tyre pressure values are to be stored » page 125.

Replace the damaged wheel or consult a specialist garage about repair options.

! WARNING

Drive cautiously and only at a moderate speed until the tightening torque has been checked.

Loosening/tightening wheel bolts

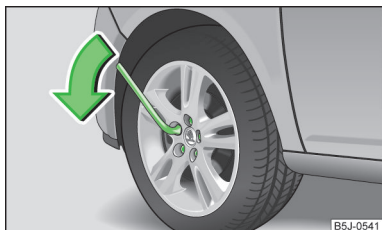

Fig. 148
Changing a wheel: Loosening the wheel bolts

Read and observe **!** on page 166 first.

Before removing the wheel bolts, the caps for the wheel bolts must be pulled off.

Releasing

- Push the wheel wrench onto the wheel bolt as far as the stop¹⁾.
- Grip the wrench at its end and turn the bolt about **one** turn in the direction of the arrow » Fig. 148.

Tightening

- Push the wheel wrench onto the wheel bolt as far as the stop¹⁾.
- Grip the wrench at its end and turn the bolt against the direction of the arrow » Fig. 148 until it is tight.

After tightening the wheel bolts, the covering caps must be replaced.

! WARNING

- Undo the wheel bolts only a little (about one turn) provided that the vehicle has not yet been jacked up. Otherwise the wheel could become loose and fall off.
- If it proves difficult to undo the bolts, carefully apply pressure to the end of the wrench with your **foot**. Keep hold of the vehicle when doing so, and make sure you keep your footing.

¹⁾ Use the appropriate adapter for undoing and tightening the anti-theft wheel bolts » page 169.

Raising the vehicle

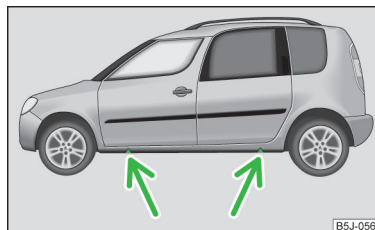

Fig. 149
Jacking points for positioning lifting jack

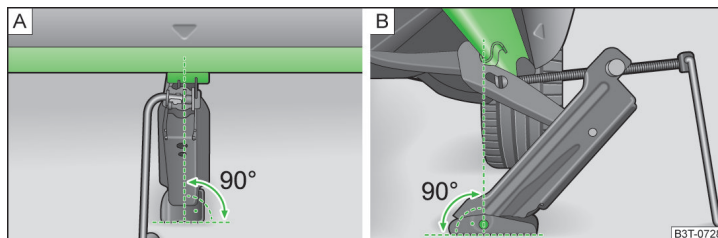

Fig. 150 Attach lifting jack

Read and observe **!** on page 166 first.

In order to raise the vehicle, the jack from the tool kit is to be used.

Position the car jack below the jacking point closest to the flat tyre » Fig. 149.

The mounting points are located on the metal bar of the lower sill on the underside of your vehicle. The positions of these are embossed by means of markings on the side surface of the lower sill » Fig. 150.

- Support the base plate of the jack with its full area resting on level ground and ensure that the jack is located in a vertical position at the jacking point » Fig. 150 - **A**.
- Position the lifting jack below the jacking point with the crank and move it up until its claw encloses the web » Fig. 150 - **B**.

- Continue turning up the jack until the wheel is just about lifted off the ground.

! WARNING

Notes for vehicle lifting

- Choose a flat and firm surface for jacking the vehicle.
- If the wheel has to be changed on a slope, first of all block the opposite wheel with a stone or similar object to prevent the vehicle from unexpectedly rolling away.
- Secure the base plate of the lifting jack with suitable means to prevent possible moving. A soft and slippery ground under the base plate may move the lifting jack, causing the vehicle to fall down. It is therefore always necessary to place the lifting jack on a solid surface or use a wide and stable base. Use a non-slip base (e.g. a rubber foot mat) if the **surface is smooth**, such as cobbled stones, tiled floor, etc.
- Only attach the lifting jack to the attachment points provided for this purpose.
- Always raise the vehicle with the doors closed.
- Never position any body parts, such as arms or legs under the vehicle, while the vehicle is raised with a lifting jack.
- When the vehicle is raised, never start the engine.

! CAUTION

It is important to ensure that the jack is correctly attached to the web of the lower fork leg, otherwise there is a risk of damage to the vehicle occurring.

Anti-theft wheel bolts

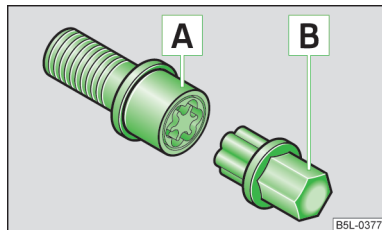

Fig. 151
Principle sketch: Anti-theft wheel bolt with adapter

Read and observe ! on page 166 first.

The anti-theft wheel bolts protect the wheels from theft. These can only be loosened or tightened with the use of adapter [B] » Fig. 151.

- Remove the full wheel trim or the caps of the wheel bolts.
- Insert adapter [B] » Fig. 151 with the toothed side all the way into the inner teeth in the head of the anti-theft wheel bolts [A].
- Push the wheel wrench onto the adapter [B] up to the stop.
- Loosen or tighten the wheel bolt » page 168.
- Remove the adapter.
- Replace the wheel trim or the caps.

To be equipped for a possible wheel change, the adapter for the anti-theft wheel bolts must always be kept in the vehicle. The adapter is stowed in the tool kit.

i Note

- Note the code number which is embossed both on the adapter and also on the end of each anti-theft wheel bolt. This number can be used to purchase a replacement adapter from ŠKODA Original Parts if necessary.
- The anti-theft wheel bolt set and adapter can be purchased from a ŠKODA Partner.

Puncture set

Introduction

This chapter contains information on the following subjects:

Components of the puncture repair kits	170
Preparations for using the breakdown kit	171
Sealing and inflating the tyre	171
Notes for driving with tyre repaired	171

Use the breakdown kit to reliably repair tyre damage caused by foreign bodies or a puncture with diameters up to approx. 4 mm.

A repair made using the breakdown kit is **never intended to replace** a permanent repair on the tyre. Its purpose is to get you to the nearest specialist garage.

The wheel need not be removed during the repair.

Do not remove foreign bodies, e.g. screws or nails, from the tyre.

The breakdown kit must not be used under the following circumstances.

- There is damage to the rim.
- The outside temperature is less than -20 °C.
- The tears or punctures are greater than 4 mm in size.

- There is damage to the tyre wall.
- Driving with very low tyre pressure or with a completely flat tyre.
- If the use-by-date (see inflation bottle) has passed.

! WARNING

- If you are in flowing traffic, switch on the hazard warning light system and set up the warning triangle at the prescribed distance! The national legal requirements must be observed.
- Park the vehicle as far away as possible from the flow of traffic. Park on as flat and firm a surface as possible.

! WARNING

- A tyre filled with sealant has the same driving characteristics as a standard tyre.
- Do not drive faster than 80 km/h (50 mph).
- Avoid accelerating at full throttle, sharp braking and fast cornering.
- The sealant is hazardous to health. Remove immediately if it comes into contact with the skin.
- Observe the manufacturer's usage instructions for the breakdown kit.

♻️ For the sake of the environment

Used sealant or sealant whose expiry date has passed must be disposed of in accordance with environmental protection regulations.

i Note

- A new bottle of sealant can be purchased from ŠKODA Original Parts.
- Immediately replace the tyre that was repaired using the breakdown kit, or consult a specialist garage about repair options.

Components of the puncture repair kits

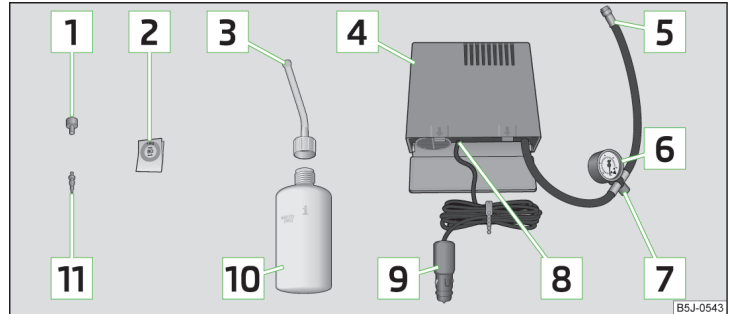

Fig. 152 Principle sketch: Components of the breakdown kit

📖 Read and observe ! on page 170 first.

Components of the set » Fig. 152

- 1** Valve remover
- 2** Sticker with "max. 80 km/h"/"max. 50 mph" speed designation
- 3** Inflation hose with plug
- 4** Air compressor
- 5** Tyre inflation hose
- 6** Tyre inflation pressure indicator
- 7** Air release valve
- 8** ON and OFF switch
- 9** 12 volt cable connector
- 10** Tyre inflator bottle with sealing agent
- 11** Replacement valve core

The valve remover **1** has a slot at its lower end which fits into the valve core.

The kit is located in a box under the floor covering in the luggage compartment. This contains a sealing means and an air compressor.



i Note

The declaration of conformity is included with the air compressor or the log folder.

Preparations for using the breakdown kit

 **Read and observe**  on page 170 first.







The following preparatory work must be carried out before using the puncture repair kit.

- Have **all the occupants get out**. The passengers should not stand on the road (instead they should remain behind a crash barrier, for instance) while the wheel is being changed.
- Switch off the engine.
- Engage the **1st gear** or place the selector lever of the automatic transmission **in the P-position**.
- Apply the **handbrake** firmly.
- Check that you can carry out the repairs with the breakdown kit » page 169.
- Uncouple a trailer.
- Remove the **breakdown kit** from the boot.
- Stick the appropriate sticker  » Fig. 152 on page 170 onto the dashboard in the driver's field of view.
- Unscrew the valve cap.
- Use the valve remover  to unscrew the valve core and place it on a clean surface (rag, paper, etc.).



Sealing and inflating the tyre







 **Read and observe**  on page 170 first.

Sealing

- Shake the tyre inflator bottle  » Fig. 152 on page 170 vigorously several times.
- Firmly screw the inflation hose  onto the tyre inflator bottle  in a clockwise direction. The film on the cap is pierced automatically.
- Remove the plug from the inflation hose  and plug the open end fully onto the tyre valve.
- Hold the bottle  with the bottom facing upwards and fill all of the sealing agent from the tyre inflator bottle into the tyre.
- Remove the empty tyre inflator bottle from the valve.
- Screw the valve core back into the tyre valve using the valve remover .

Inflating

- Screw the air compressor tyre inflation hose  » Fig. 152 on page 170 firmly onto the tyre valve.
- Check that the air release valve  is closed.

- Start the engine and run it in idle.
- Plug the connector  into 12 Volt socket » page 82, 12-volt power outlet.
- Switch on the air compressor with the ON and OFF switch .
- Allow the air compressor to run until a pressure of 2.0 - 2.5 bar is achieved. Maximum run time of 8 minutes » .
- Switch off the air compressor.
- If you cannot reach an air pressure of 2.0 - 2.5 bar, unscrew the tyre inflation hose  from the tyre valve.
- Drive the vehicle 10 metres forwards or backwards to allow the sealing agent to "distribute" in the tyre.
- Firmly screw the tyre inflation hose  back onto the tyre valve and repeat the inflation process.
- If you cannot reach the required tyre inflation pressure here either, this means the tyre has sustained too much damage. You cannot seal with tyre with the breakdown kit » .
- Switch off the air compressor.
- Remove the tyre inflation hose  from the tyre valve.

Once a tyre pressure of 2.0 - 2.5 bar is reached, the journey may be continued at a maximum speed of 80 km/h (50 mph).

WARNING

- If you cannot inflate the tyre to at least 2.0 bar, this means the damage sustained was too serious. The sealing agent cannot be used to seal the tyre.  Do not drive the vehicle any further! Seek help from a specialist garage.
- The tyre inflation hose and air compressor may get hot as the tyre is being inflated - there is a risk of burning.

CAUTION

Switch off the air compressor after running 8 minutes at the latest - there is a risk of overheating. Allow the air compressor to cool a few minutes before switching it on again.

Notes for driving with tyre repaired

 **Read and observe**  on page 170 first.

The inflation pressure of the repaired tyre must be checked after driving for 10 minutes. ▶

If the tyre pressure is 1.3 bar or less

➤ **Do not drive the vehicle!** You cannot properly seal with tyre with the breakdown kit.

If the tyre pressure is 1.3 bar or more

➤ Set the tyre pressure back to the correct value.

➤ Continue driving carefully to the nearest specialist garage at a maximum speed of 80 km/h (50 mph).

Jump-starting

Introduction

This chapter contains information on the following subjects:

Jump-starting using the battery from another vehicle _____ 172

Jump-starting in vehicles with the START-STOP system _____ 173

The battery of another vehicle can be used to jump-start your vehicle if the engine will not start because the battery is flat.

! WARNING

- Pay attention to the warning instructions relating to work in the engine compartment » [page 145](#).
- A discharged vehicle battery may already freeze at temperatures just below 0 °C. If the battery is frozen, do not jump start with the battery of another vehicle – there is a risk of explosion.
- Keep any sources of ignition (naked flame, smouldering cigarettes, etc.) away from the battery – risk of explosion!
- Never jump-start vehicle batteries with insufficient acid levels – risk of explosion and chemical burns.
- The vent screws of the battery cells must be tightened firmly.

i Note

We recommend you buy jump-start cables from a car battery specialist.

Jump-starting using the battery from another vehicle

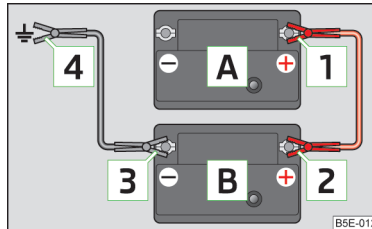

Fig. 153
Jump-starting: A – flat battery, B – battery providing current

Read and observe ! on page 172 first.

The starting process using the battery of another vehicle requires the use of jumper cables.

The jump-start cables must be attached in the following sequence.

- Attach clamp **1** to the positive terminal of the discharged battery **A** » [Fig. 153](#).
- Attach clamp **2** to the positive terminal of the battery supplying power **B**.
- Attach clamp **3** to the negative terminal of the battery supplying power **B**.
- Attach clamp **4** to a solid metal component firmly connected to the engine block or to the engine block itself.

Starting engine

- Start the engine on the vehicle providing the power and allow it to idle.
- Start the engine of the vehicle with the discharged battery.
- If the engine does not start, halt the attempt to start the engine after 10 seconds and wait for 30 seconds before repeating the process.
- Remove the jumper cables exactly in the **reverse** sequence as for clamping.

Both batteries must have a rated voltage of 12 V. The **capacity** (Ah) of the battery supplying the power must not be significantly less than the capacity of the discharged battery in your vehicle.

Jump-start cables

Only use jump-start cables which have an adequately large cross-section and insulated terminal clamps. Obey the instructions of the jump start cable manufacturer.

Positive cable - colour coding in the majority of cases is red.

Negative cable - colour coding in the majority of cases is black. ▶

! WARNING

- Do not clamp the jump-start cable to the negative terminal of the discharged battery. There is the risk of detonating gas seeping out the battery being ignited by the strong spark which results from the engine being started.
- The non-insulated parts of the terminal clamps must never touch each other – there is a risk of short circuit.
- The jump-start cable connected to the positive terminal of the battery must not come into contact with electrically conducting parts of the vehicle – there is a risk of short circuit.
- Route the jump-start cables so that they cannot be caught by any rotating parts in the engine compartment.
- There must not be any contact between the two vehicles otherwise current may flow as soon as the negative terminals are connected.

Jump-starting in vehicles with the START-STOP system

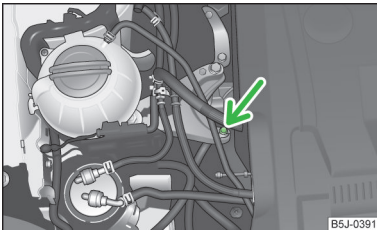

Fig. 154
Engine earth: START-STOP system

📖 Read and observe ! on page 172 first.

The jump-start cable must only be connected to the engine earthing point on vehicles with the START-STOP system » Fig. 154.

Towing the vehicle

📖 Introduction

This chapter contains information on the following subjects:

Front towing eye _____	174
Rear towing eye _____	174
Vehicles with a tow hitch _____	174

The following guidelines must be observed when towing.

Vehicles with **manual transmission** may be towed in with a tow bar or a tow rope or with the front or rear wheels raised.

Vehicles with **automatic transmission** may be towed in with a tow bar or a tow rope or with the front wheels raised. If the vehicle is raised at rear, the automatic gearbox is damaged!

Driver of the tow vehicle

- Engage the clutch gently when starting off or depress the accelerator particularly gently if the vehicle is fitted with an automatic gearbox.
- Only then, approach correctly when the rope is taut.

The maximum towing speed is **50 km/h**.

Driver of the towed vehicle

- Switch on the ignition so that the steering wheel is not locked and so that the turn signal lights, windscreen wipers and windscreen washer system can be used.
- Take the vehicle out of gear or move the selector lever into position **N** if the vehicle is fitted with an automatic gearbox.

Please note that the brake servo unit and power steering only operate if the engine is running. If the engine is not running, significantly more physical force is required to depress the brake pedal and steer the vehicle.

If using a tow rope, ensure that it is always kept taut.

Both drivers should be familiar with the problems which might possibly occur while a vehicle is being towed. Unskilled drivers should not attempt to tow in another vehicle or to be towed in.

The vehicle must be transported on a special breakdown vehicle or trailer if it is not possible to tow in the vehicle in the way described or if the towing distance is greater than 50 km.

! WARNING

- When towing, respect the national legal provisions, especially those which relate to the identification of the towing vehicle and the vehicle being towed.
- When towing, exercise increased caution.
- The tow rope must not be twisted, as this may in certain circumstances result in the front towing eye being unscrewed on your vehicle.
- Do not use a one-sided twisted tow rope, because the towing eye could become unscrewed on the vehicle.

! CAUTION

- Do not tow start the engine - there is a risk of damaging the engine and the catalytic converter. The battery from another vehicle can be used as a jump-start aid » [page 172, Jump-starting](#).
- If the gearbox no longer contains any oil, your vehicle must only be towed with the front axle raised clear of the ground or on a breakdown vehicle or trailer.
- To protect both vehicles when tow-starting or towing, the tow rope should be elastic. Thus one should only use plastic fibre rope or a rope made out of a similarly elastic material.
- There is always a risk of excessive stresses and damage resulting at the points to which you attach the tow rope or tow bar when you attempt to tow a vehicle which is not standing on a paved road.
- Attach the tow rope or the tow bar to the **towing eyes** » [page 174, Front towing eye](#) or » [page 174, Rear towing eye](#) to the **detachable ball head of the towing equipment** » [page 126](#).

i Note

We recommend using a tow rope from ŠKODA Original Accessories, which is available from a ŠKODA Partner.

Front towing eye

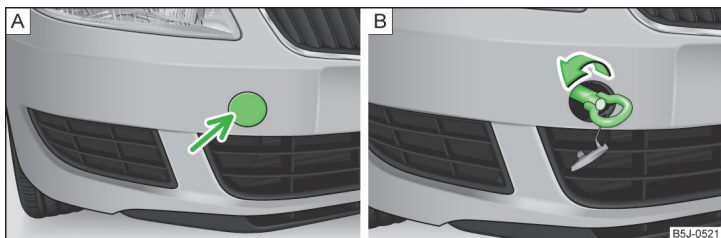

Fig. 155 Removing the cap / installing the towing eye

📖 Read and observe ! and ! on page 173 first.

➤ Press the cover in the arrow area » [Fig. 155 - A](#).

The cover comes loose.

➤ Remove the cap from the front bumper and leave it hanging on the vehicle.

➤ Screw in the towing eye by hand up to the stop » [Fig. 155 - B](#).

For tightening purposes, we recommend, for example, using the wheel wrench, towing eye from another vehicle or a similar object that can be pushed through the eye.

➤ After unscrewing the cap of the towing eye, insert the cap in the lower area and then press the opposite side of the cap.

The cap must engage firmly.

! WARNING

The towing eye must always be screwed in fully and firmly tightened, otherwise the towing eye can tear when towing in or tow-starting.

Rear towing eye

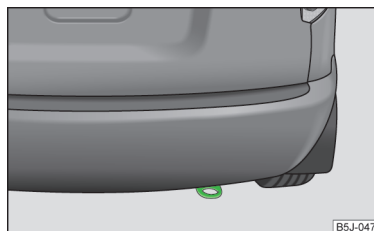

Fig. 156
Rear towing eye

📖 Read and observe ! and ! on page 173 first.

The rear towing eye is located below the rear bumper on the right » [Fig. 156](#).

Vehicles with a tow hitch

📖 Read and observe ! and ! on page 173 first.

The removable towing ball may be fitted and used for towing on vehicles with a factory fitted tow hitch » [page 126, Hitch and trailer](#).

Towing the vehicle using the towing device is a viable alternative solution to using the towing eye.

! CAUTION

The detachable ball rod and/or the vehicle can be damaged if an unsuitable tow bar is used.

i Note

The detachable ball rod must always be in the vehicle so that it can be used for towing, if necessary.

Fuses and light bulbs

Fuses

Introduction

This chapter contains information on the following subjects:

Fuses in the dash panel 176

Fuses in the engine compartment 177

Individual electrical circuits are protected by fuses.

- Before replacing a fuse, switch off the ignition and the appropriate consumer
- Find out which fuse belongs to the component that is not operating » [page 176](#), *Fuses in the dash panel* or » [page 177](#), *Fuses in the engine compartment*.
- Take the plastic clip out of its fixture in the cover of the fuse box, place it on the relevant fuse and pull it out.

Fuse colour	Maximum amperage
light brown	5
dark brown	7.5
red	10
blue	15
yellow	20
white	25
green	30

! WARNING

Always read and observe the warnings before completing any work in the engine compartment » [page 145](#).

! CAUTION

- “Never repair” fuses or replace them with a fuse of a higher amperage - there is a risk of fire. This may also cause damage at another part of the electrical system.
- A blown fuse is recognisable by the molten metal strip. Replace the faulty fuse with a new one of the **same** amperage.
- If a newly inserted fuse burns through again, then a specialist should be consulted immediately.

i Note

- We recommend always carrying replacement fuses in the vehicle. A box of replacement fuses can be purchased from ŠKODA Original Accessories.
- There can be multiple power consuming devices for one fuse.
- A single consumer may use several fuses.

Fuses in the dash panel



Fig. 157
Underside of the dash panel: Distribution board cover.

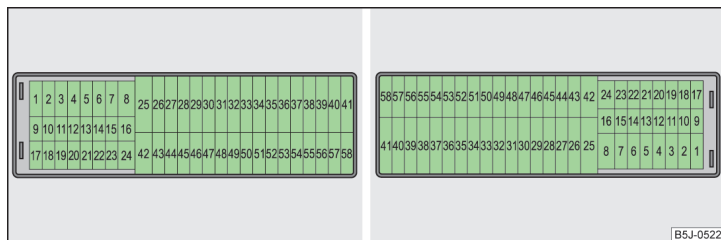

Fig. 158 Schematic representation of the fuse box for vehicles with left-hand steering/right-hand steering

Read and observe and on page 175 first.

The fuses are located on the left side of the dash panel behind a cover.

- Carefully remove the cover in the direction of the arrow » Fig. 157.
- After the fuse has been replaced, replace the cover in the dash panel in the opposite direction of the arrow so that the guide lugs are guided into the openings of the dash panel. Close the cover until it clicks into place.

Fuse assignment in the dash panel

No.	Consumer
1	S-contact
2	START-STOP, air-conditioning system
3	Instrument cluster, headlamp beam adjustment
4	Control unit for ABS, button for START STOP
5	Petrol engine: Speed regulating system
6	Reversing light (manual gearbox)
7	Ignition, engine control unit, automatic gearbox
8	Brake pedal switch, clutch pedal switch
9	Operating controls for the heating, control unit for air conditioning system, parking aid, control unit for cornering lights, radiator fan, washing nozzles
10	Windscreen Wiper and Washer System
11	Mirror adjustment
12	Control unit for trailer detection
13	Control unit for automatic gearbox
14	Motor for halogen projector headlights with cornering light function
15	PDA navigation system
16	Electro-hydraulic power steering
17	Light switch power supply
18	Mirror heater
19	S-contact
20	Alarm
21	Reversing light, fog lights with the function CORNER
22	Operating controls for the heating, control unit for air conditioning system, parking aid, mobile phone, instrument cluster, steering angle sender, ESC, vehicle voltage control unit, multifunction steering wheel
23	Interior lighting, storage compartment and luggage compartment, side lights
24	Central control unit
25	Seat heaters
26	Rear window wiper

No.	Consumer
27	Telephone preinstallation
28	Petrol engine: AKF valve, Diesel engine: Control flap
29	Injection, coolant pump
30	Fuel pump, ignition, Cruise control system, operation of PTC relay
31	Lambda probe
32	High pressure fuel pump, pressure valve
33	Engine control unit
34	Engine control unit, vacuum pump
35	Daytime running lights/radio for vehicles with START-STOP
36	Main beam
37	Rear fog light, DC/DC converter START-STOP
38	Fog lights
39	Air blower for heating
40-41	Not assigned
42	Rear window heater
43	Horn
44	Windscreen wipers
45	Central control unit for convenience system
46	Engine control unit, fuel pump
47	Cigarette lighter, power socket in the luggage compartment
48	ABS, START-STOP (DC/DC) converter, ESC
49	Turn signal lights, brake lights
50	START-STOP (DC/DC) transformer, radio
51	Electrical power window (front and rear) - left side
52	Electrical power window (front and rear) - right side
53	Parking light = left side, electrical sliding/tilting roof
54	START-STOP (instrument cluster), alarm
55	Control unit for automatic gearbox
56	Headlight cleaning system, parking light - right side
57	Left low beam, headlight range adjustment
58	Low beam on the right

Fuses in the engine compartment

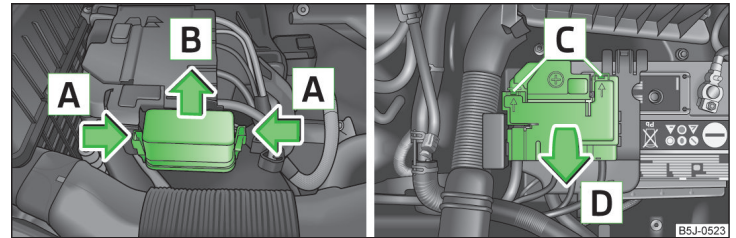

Fig. 159 Vehicle battery: Distribution board cover.

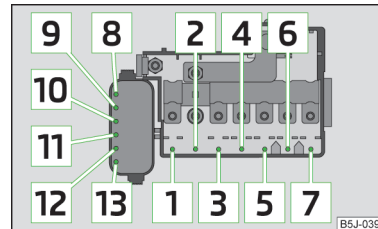

Fig. 160 Schematic representation of fuse box in engine compartment

📖 Read and observe **I** and **II** on page 175 first.

- Press the securing clips on the fuse box cover together at the same time in the direction of arrow **A** » Fig. 159 and remove the cover in the direction of arrow **B**.
- Release the fixtures in the openings **C** using a flat screwdriver and fold the cover upwards in direction of arrow **D**.

Fuse assignment in engine compartment

No.	Consumer
1	Generator
2	Not assigned
3	Interior
4	Electrical auxiliary heating system
5	Interior

No.	Consumer
6	Glow plugs, radiator fan
7	Electro-hydraulic power steering
8	ABS or TCS or ESC
9	Radiator fan
10	Automatic gearbox
11	ABS or TCS or ESC
12	Central control unit
13	Electrical auxiliary heating system

i Note

Fuses 1-7 are replaced by a specialist garage.

Replacing bulbs

Introduction

This chapter contains information on the following subjects:

Headlights	179
Changing the low beam and high beam bulb (halogen headlights)	179
Changing the high beam bulb (halogen projector headlights)	179
Changing the high beam bulb (halogen projector headlights)	180
Changing the front turn signal bulb	180
Changing the front parking light bulb	180
Fog lights and daytime running lights	180
Fog light, Roomster Scout	181
Replacing the bulb for the licence plate light	181
Rear Light	181

Some manual skills are required to change a bulb. For this reason, we recommend having bulbs replaced by a specialist garage or seeking other expert help in the event of any uncertainties.

- Switch off the ignition and all of the lights before replacing a bulb.
- Faulty bulbs must only be replaced with the same type of bulbs. The designation is located on the light socket or the glass bulb.
- A stowage compartment for replacement bulbs is located in a plastic box in the spare wheel or underneath the floor covering in the boot.

! WARNING

- Always read and observe the warnings before completing any work in the engine compartment » [page 145](#).
- Accidents can be caused if the road in front of the vehicle is not sufficiently illuminated and the vehicle cannot or can only be seen with difficulty by other road users.
- Bulbs H7 and H4 are pressurised and may burst when changed - there is a risk of injury. We therefore recommend wearing gloves and safety glasses when changing a bulb.
- Switch off the respective vehicle light when changing the bulb.

! CAUTION

- Do not take hold of the glass bulb with naked fingers (even the smallest amount of dirt reduces the working life of the light bulb). Use a clean cloth, napkin, or similar.
- When removing and installing the number plate light and tail light make sure that the paintwork of the vehicle and the tail light are not damaged.

i Note

- This Owner's Manual only describes the replacement of bulbs where it is possible to replace the bulbs on your own without any complications arising. Other bulbs must be replaced by a specialist garage.
- We recommend that a box of replacement bulbs always be carried in the vehicle. Replacement bulbs can be purchased from ŠKODAOriginal Accessories.
- We recommend having the headlight settings checked by a specialist garage after replacing a bulb in the main beam, low beam or fog lights.
- Visit a specialist garage if an LED is faulty.

Headlights

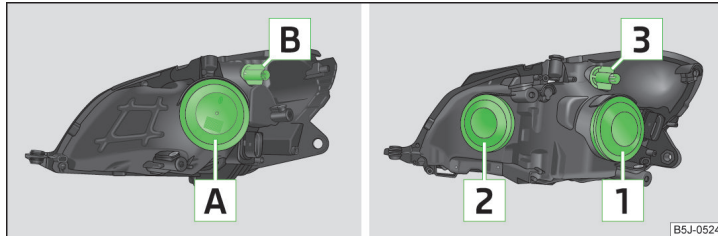

Fig. 161 Bulb arrangement: Halogen headlights/halogen projector headlights

Read and observe  and  on page 178 first.

Bulb arrangement in the Halogen headlamp

A - low beam, main beam and side lights

B - front turn signal light

Bulb arrangement in the Halogen projector headlights

1 - low beam / low and main beam

2 - parking light / parking and main beam lights

3 - turn signal lights

Changing the low beam and high beam bulb (halogen headlights)

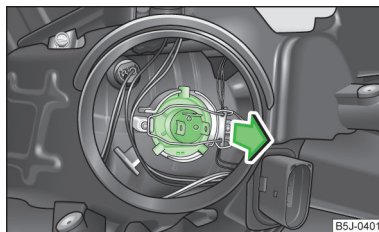

Fig. 162 Removing bulbs for low and main beam

Read and observe  and  on page 178 first.

Remove the protective cap **A** » Fig. 161 on page 179.

- Remove the connector from the bulb, unlock the securing clip and remove the bulb in the direction of the arrow » Fig. 162.
- Insert a new light bulb in such a way that the fixing lugs of the bulb socket fit in the recesses of the reflector.
- Lock the circlip and insert the connector in the bulb.
- Fit the protective cap **A**.

Changing the high beam bulb (halogen projector headlights)

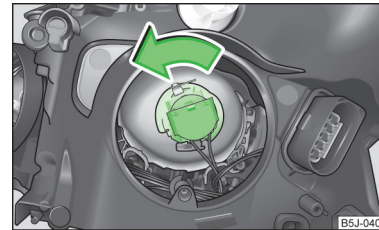

Fig. 163 Removing the bulb for the low beam

Read and observe  and  on page 178 first.

- Remove the protective cap **1** » Fig. 161 on page 179.
- Turn the socket with the bulb to the stop in the direction of the arrow » Fig. 163 and remove it.
- Replace the bulb, insert the connector and new bulb and turn to the stop in the opposite direction to that of the arrow.
- Fit the protective cover **1**.

Changing the high beam bulb (halogen projector headlights)

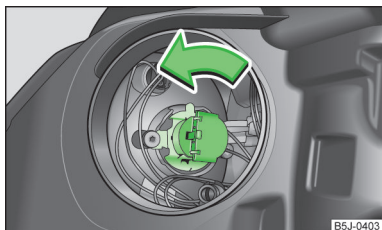

Fig. 164
Removing the bulb for the main beam

Read and observe **!** and **!** on page 178 first.

- Remove the protective cap **[2]** » Fig. 161 on page 179.
- Turn the socket with the bulb to the stop in the direction of the arrow » Fig. 164 and remove it.
- Replace the bulb, insert the connector and new bulb and turn to the stop in the opposite direction to that of the arrow.
- Fit the protective cover **[2]**.

Changing the front turn signal bulb

Read and observe **!** and **!** on page 178 first.

- Remove the bulb holder **[B]** » Fig. 161 on page 179 or the bulb holder **[3]** to the stop in an **anti-clockwise** direction and remove with the bulb for the turn signal.
- Replace the bulb, insert the bulb holder with the new bulb and turn **clockwise** to the stop.

Changing the front parking light bulb

Read and observe **!** and **!** on page 178 first.

- Remove the protective cap **[A]** » Fig. 161 on page 179 or **[2]**.
- Grasp the lamp holder and remove it from the bulb housing.
- Replace the light bulb and insert the lamp holder back into the headlamp with the bulb.
- Fit the protective cap.

Fog lights and daytime running lights

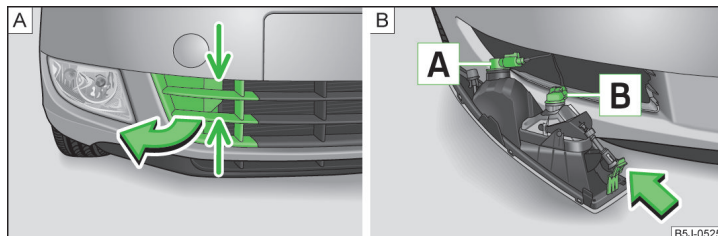

Fig. 165 Front bumper: Protective grille/removing the fog light

Read and observe **!** and **!** on page 178 first.

Bulb arrangement » Fig. 165

- [A]** Light bulb for daytime driving light
- [B]** Light bulb for fog lights

Removing the cap

- Grasp the protective grille in the areas marked by the arrows » Fig. 165 - **[A]** and remove the cover in the direction of the arrow.

Replacing light bulbs for fog lights/daytime running lights

- Insert your hand into the opening in the protective grille and press the catch » Fig. 165 - **[B]** in the direction of the arrow.
- Remove the fog lamp.
- Turn the connector with the bulb in **counter-clockwise** up to the stop and remove.
- Replace the bulb, insert the holder with the new bulb and turn **clockwise** to the stop.
- To re-install the fog light, first of all place the fog light with the lug on the side opposite the licence plate.
- Press in the fog lamp on the side closest to the licence plate.
- Insert the cap, beginning with the lug on the side opposite the license plate.
- Press in the cap on the side facing the license plate. The cap must engage firmly.

Fog light, Roomster Scout

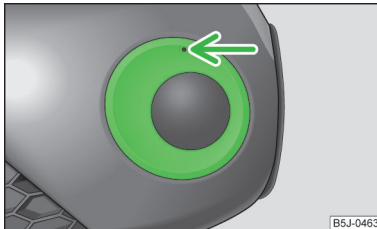

Fig. 166
Front bumper: Roomster Scout

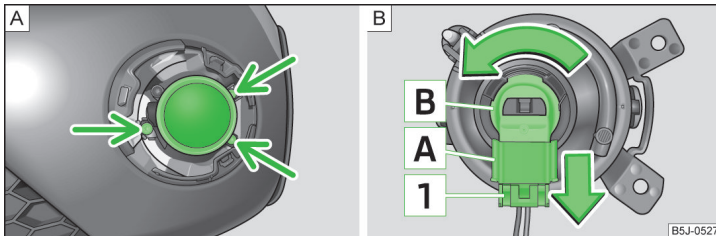

Fig. 167 Front bumper: Fog lights/fog lights: Replacing the light bulb

Read and observe **!** and **!** on page 178 first.

Removing the cap and fog light

- › Insert the tool » page 166, *Vehicle tool kit* into the opening above the fog light » Fig. 166 and remove the cover.
- › Unscrew the screws » Fig. 167 - **A** with the screwdriver » page 166, *Vehicle tool kit*.
- › Remove the fog lamp.

Changing light bulbs and installing fog lights

- › Press the locking tab **1** » Fig. 167 on the connector **A** and remove the connector from the bulb holder **B**.
- › Turn the bulb holder **B** and bulb in the direction of the arrow to the stop and remove.
- › Replace the bulb, insert the bulb holder and new bulb and turn in the opposite direction to that of the arrow to the stop.
- › Insert the plug **A** into the socket **B**.

- › Retighten the screws and insert the cap. The cap must engage firmly.

Replacing the bulb for the licence plate light

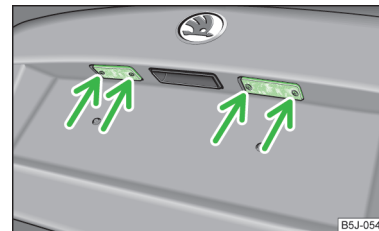

Fig. 168
Remove the licence plate light

Read and observe **!** and **!** on page 178 first.

- › Open the tailgate and unscrew the glass cover » Fig. 168.
- › Remove the faulty bulb from the holder and insert a new one.
- › Replace the glass cover and push in until the stop. Make sure that you install the rubber seal in the right direction.
- › Slightly screw the glass cover.

Rear Light

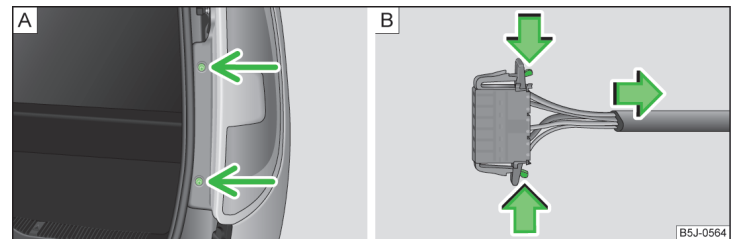

Fig. 169 Removing the tail light assembly/disconnecting the plug connection

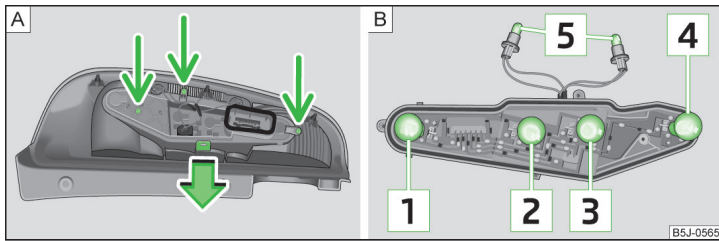

Fig. 170 Remove the middle part of the light/bulb arrangement

📖 Read and observe **A** and **B** on page 178 first.

Bulb arrangement in the tail light » Fig. 170

- 1** Brake light
- 2** Flashing
- 3** Reversing light
- 4** The rear fog light
- 5** Parking lights

Removing and installing the tail light

- Open the tailgate.
- Unscrew the light assembly » Fig. 169 - **A**.
- Grip the light in the upper and lower area and move backwards somewhat.
- Unplug the connector » Fig. 169 - **B**.
- To access the bulbs, unscrew the middle of the light assembly and press off the tabs » Fig. 170 - **A**.
- To reinstall, screw the middle part of the light onto the housing of the tail light.
- Reconnect the plug connection and put the light into the original position.
- Screw the light into place

Replacing the bulbs in the tail lamp assembly

- Remove the faulty bulb **1**, **2**, **3** or **4** » Fig. 170 from the holder and fit a new bulb.
- To replace the bulb, turn the bulb holder **5** **anti-clockwise** up to the stop and remove it from the housing.
- Replace the bulb, insert the holder with the bulb into the housing and turn in a **clockwise direction** to the the stop.

Technical data

Technical data

Vehicle data

Introduction

This chapter contains information on the following subjects:

Vehicle characteristics	183
Operating weight and payload	184
Measurement of fuel consumption and CO ₂ emissions according to ECE	
Regulations and EU Directives	184
Dimensions	185
Vehicle-specific details per engine type	186

The details given in the vehicle's technical documentation always take precedence over the details in the Owner's Manual.

The listed performance values were determined without performance-reducing equipment, e.g. air conditioning system.

Vehicle characteristics

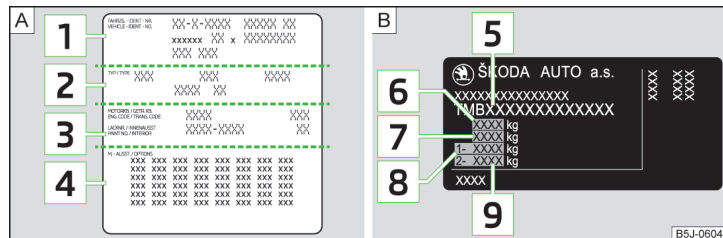

Fig. 171 Vehicle data sticker/type plate

Vehicle data sticker

The vehicle data sticker » Fig. 171 - A is located on the base of the luggage compartment and is also fixed into the service schedule.

The vehicle data sticker contains the following data.

- 1 Vehicle identification number (VIN)
- 2 Vehicle type
- 3 Gearbox code/paint number/interior equipment/engine output/engine code
- 4 Partial vehicle description

Type plate

The type plate » Fig. 171 - B is located at the bottom of the B-pillar on the right driver's side.

The type plate contains the following data.

- 5 Vehicle identification number (VIN)
- 6 Maximum permissible gross weight
- 7 Maximum permissible towed weight (towing vehicle and trailer)
- 8 Maximum permissible front axle load
- 9 Maximum permissible rear axle load

Vehicle identification number (VIN)

The vehicle identification number - VIN (vehicle body number) is stamped on the right hand suspension strut dome in the engine compartment. This number is also located on a sign on the lower left hand edge below the windscreen (together with a VIN bar code), and on the type plate.

Engine number

The engine number (three-digit code letter and serial number) is stamped onto the engine block.

Supplementary Information (applies to Russia)

The full type approval number of the means of transport is indicated in the registration documents.

! WARNING

Do not exceed the specified maximum permissible weights - risk of accident and damage!

Operating weight and payload

Operating weight

This value represents the minimum operating weight without additional weight-increasing equipment such as air conditioning system, spare wheel, or trailer hitch.

The specified operating weight is for orientation purposes only.

The operating weight also contains the weight of the driver (75 kg), the weight of the operating fluids, the tool kit, and a fuel tank filled to 90 % capacity.

Operating weight of the vehicle » [page 186](#), *Vehicle-specific details per engine type*.

Payload

It is possible to calculate the approximate maximum payload from the difference between the permissible total weight and the operating weight.

The payload consists of the following weights.

- The weight of the passengers.
- The weight of all items of luggage and other loads.
- The weight of the roof, including the roof rack system.
- The weight of the equipment that is excluded from the operating weight.
- Trailer drawbar load when towing a trailer (max. 50 kg).

i Note

If required, you can find out the precise weight of your vehicle at a specialist garage.

Measurement of fuel consumption and CO₂ emissions according to ECE Regulations and EU Directives

The data on fuel consumption and CO₂ emissions were not available at the time of going to press.

The data on fuel consumption and CO₂ emissions are given on the ŠKODA websites or in the sales and technical vehicle documentation.

The measurement of the intra-urban cycle begins with a cold start of the engine. Afterwards urban driving is simulated.

In the extra-urban driving cycle, the vehicle is accelerated and decelerated in all gears, corresponding to daily routine driving conditions. The driving speed varies between 0 and 120 km/h.

The calculation of the combined fuel consumption considers a weighting of about 37 % for the intra-urban cycle and 63 % for the extra-urban cycle.

i Note

- The fuel consumption and emission levels given on the ŠKODA websites or in the commercial and technical vehicle documentation have been established in accordance with rules and under conditions that are set out by legal or technical rules for the determination of operational and technical data of motor vehicles.
- Depending on the extent of the equipment, the driving style, traffic conditions, weather influences and vehicle condition, consumption values can in practice result in fuel economy figures in the use of the vehicle that differ from the fuel consumption values listed on the ŠKODA websites or in the commercial and technical vehicle documentation.

Dimensions

Vehicle dimensions for operating weight without driver (in mm)

	ROOMSTER	PRAKTIK	SCOUT
Length	4214	4213	4240
Width	1684	1684	1695
Width including exterior mirror	1882	1882	1882
Height	1607	1607	1650
Clearance	140	140	141
Wheel base	2620	2620	2620
Track gauge front/rear	1436/1500 (1420/1484) ^{a)}	1436/1500 (1420/1484) ^{a)}	1427/1494

^{a)} Valid for vehicles, which have factory-fitted 15" wheels.

Vehicle-specific details per engine type

The specified values have been determined in accordance with rules and under conditions set out by legal or technical requirements for determining operational and technical data for motor vehicles.

1.2 ltr./51 kW engine

Output (kW at rpm)	Maximum torque (Nm at rpm)	Number of cylinders/displacement (cm ³)
51/5400	112/3000	3/1198

Performance and Weights		ROOMSTER	PRAKTIK
Top speed (km/h)		159	
Acceleration 0-100 km/h (s)		15.9	
Operating weight (in kg)		1200/1215 ^{a)}	1170 ^{b)} / 1180 ^{c)}
Permissible trailer load, braked (kg)	Increases up to 12 %	700	
	Increases up to 8 %	900	
Permissible trailer load, unbraked (kg)		600/450 ^{d)}	580/450 ^{d)}

^{a)} Applies to vehicles of category N1.

^{b)} Applies to 14" rims.

^{c)} Applies to 15" rims.

^{d)} Vehicles without ABS.

1.2 ltr./63 kW TSI engine

Output (kW at rpm)	Maximum torque (Nm at rpm)	Number of cylinders/displacement (cm ³)
63/4800	160/1500-3500	4/1197

Performance and Weights		ROOMSTER	PRAKTIK
Top speed (km/h)		172	
Acceleration 0-100 km/h (s)		12.6	
Operating weight (in kg)		1221/1237 ^{a)}	1191 ^{b)} / 1201 ^{c)}
Permissible trailer load, braked (kg)	Increases up to 12 %	1000	
	Increases up to 8 %	1200	
Permissible trailer load, unbraked (kg)		610/450 ^{d)}	590/450 ^{d)}

^{a)} Applies to vehicles of category N1.

^{b)} Applies to 14" rims.

^{c)} Applies to 15" rims.

^{d)} Vehicles without ABS.

1.2 ltr./77 kW TSI engine

Output (kW at rpm)	Maximum torque (Nm at rpm)	Number of cylinders/displacement (cm ³)
77/5000	175/1500-4100	4/1197

Performance and Weights		ROOMSTER MG5	ROOMSTER DSG7
Top speed (km/h)		184	184
Acceleration 0-100 km/h (s)		10.9	11.0
Operating weight (in kg)		1237	1271
Permissible trailer load, braked (kg)	Increases up to 12 %	1100	
	Increases up to 8 %	1200	
Permissible trailer load, unbraked (kg)		610/450 ^{a)}	630/450 ^{a)}

^{a)} Vehicles without ABS.

1.4 ltr./63 kW engine

Output (kW at rpm)	Maximum torque (Nm at rpm)	Number of cylinders/displacement (cm ³)
63/5000	132/3800	4/1390

Performance and Weights		ROOMSTER	PRAKTIK
Top speed (km/h)		171	
Acceleration 0-100 km/h (s)		13.0	
Operating weight (in kg)		1209/1224 ^{a)}	1179 ^{b)} / 1189 ^{c)}
Permissible trailer load, braked (kg)	Increases up to 12 %	900	
	Increases up to 8 %	1100	
Permissible trailer load, unbraked (kg)		600/450 ^{d)}	580/450 ^{d)}

^{a)} Applies to vehicles of category N1.

^{b)} Applies to 14" rims.

^{c)} Applies to 15" rims.

^{d)} Vehicles without ABS.

1.6 ltr./77 kW engine

Output (kW at rpm)	Maximum torque (Nm at rpm)	Number of cylinders/displacement (cm ³)
77/5600	153/3800	4/1598

Performance and Weights		ROOMSTER MG5	ROOMSTER AG6
Top speed (km/h)		183	180
Acceleration 0-100 km/h (s)		11.3	12.5
Operating weight (in kg)		1233	1278
Permissible trailer load, braked (kg)	Increases up to 12 %	1000	
	Increases up to 8 %	1200	
Permissible trailer load, unbraked (kg)		610/450 ^{a)}	630/450 ^{a)}

^{a)} Vehicles without ABS.

1.2 ltr./55 kW TDI CR engine

Output (kW at rpm)	Maximum torque (Nm at rpm)	Number of cylinders/displacement (cm ³)
55/4200	180/2000	3/1199

Performance and Weights		ROOMSTER	ROOMSTER GreenLine	PRAKTIK
Top speed (km/h)		162	165	162
Acceleration 0-100 km/h (s)		15.5	15.4	15.5
Operating weight (in kg)		1308	1314	1278
Permissible trailer load, braked (kg)	Increases up to 12 %	1000		
	Increases up to 8 %	1200		
Permissible trailer load, unbraked (kg)		650/450 ^{a)}		630/450 ^{a)}

^{a)} Vehicles without ABS.

1.6 ltr./66 kW TDI CR engine

Output (kW at rpm)	Maximum torque (Nm at rpm)	Number of cylinders/displacement (cm ³)
66/4200	230/1500-2500	4/1598

Performance and Weights	ROOMSTER	PRAKTIK
Top speed (km/h)	171	
Acceleration 0-100 km/h (s)	13.3	
Operating weight (in kg)	1322	1292
Permissible trailer load, braked (kg)	1200	
Permissible trailer load, unbraked (kg)	660/450 ^{a)}	640/450 ^{a)}

^{a)} Vehicles without ABS.

1.6 ltr./77 kW TDI CR engine

Output (kW at rpm)	Maximum torque (Nm at rpm)	Number of cylinders/displacement (cm ³)
77/4400	250/1500-2500	4/1598

Performance and Weights	
Top speed (km/h)	181
Acceleration 0-100 km/h (s)	11.5
Operating weight (in kg)	1322
Permissible trailer load, braked (kg)	1200
Permissible trailer load, unbraked (kg)	660/450 ^{a)}

^{a)} Vehicles without ABS.

Index

A

Abroad

- Driving abroad _____ 118
- Unleaded petrol _____ 118

ABS _____ 120

- Warning light _____ 42

Accessories _____ 132

Adjusting

- Belt height _____ 15
- Exterior mirrors _____ 68
- Seat _____ 69
- Steering wheel _____ 10

Adjusting the seats _____ 9

Aerial _____ 135

- See windows _____ 138

Airbag _____ 16

- Deactivating _____ 20
- Deactivating the front passenger airbag _____ 21
- Deployment _____ 17
- Front airbag _____ 18
- Head airbag _____ 19
- Modifications and damage to the airbag system _____ 134
- Side airbag _____ 19

Airbag system _____ 16

Air conditioning

- Operation _____ 93

Air conditioning system

- Air outlets _____ 90
- Climatronic _____ 95
- Manual air conditioning system _____ 93

Air outlets _____ 90

Alarm _____ 53

Anti-theft alarm system _____ 53

- Operation _____ 53
- Trailer _____ 131

Anti-theft wheel bolts _____ 169

Antilock Braking System _____ 120

Armrest _____ 86

Ashtray _____ 81

ASR _____ 120

- warning light _____ 42

Assist systems

- ABS _____ 42, 120
- ASR _____ 42, 120
- Cruise Control System _____ 121
- EDL _____ 120
- ESC _____ 42, 119
- Parking aid _____ 120
- START-STOP _____ 123

Audio

- see radio / navigation system _____ 4

Auto Check Control _____ 38

Automatic gearbox

- Selector lever-emergency unlocking _____ 112
- Starting-off and driving _____ 112
- Tiptronic _____ 111

Automatic load deactivation _____ 156

Automatic transmission _____ 110

- Kickdown _____ 112
- Malfunction _____ 112
- Selector lever lock _____ 111
- Using the selector lever _____ 110

AUX _____ 104

Avoiding damage to the vehicle

- Driving through water _____ 117

Avoiding damage to your vehicle _____ 117

B

Ball head

- Check fitting _____ 128
- Fitting _____ 127
- Ready position _____ 127
- Removing _____ 128

Belts _____ 12

Belt tensioners _____ 15

Bicycle carrier _____ 78

Bonnet

- Closing _____ 146
- Opening _____ 146

Boot

- Cover _____ 75
- Emergency unlocking _____ 55
- Fastening elements _____ 74
- Fixing nets _____ 75
- Folding hooks _____ 74
- see Boot lid _____ 55
- Unlocking the boot lid _____ 55

Boot lid _____ 55

- automatic locking _____ 55

Brake assist _____ 119

Brake booster _____ 108

Brake fluid _____ 152

- Checking _____ 152
- Display messages _____ 40
- specification _____ 152

Brakes

- Brake booster _____ 108
- Brake fluid _____ 152
- Handbrake _____ 109
- Indicator light _____ 40
- Running in _____ 113

Braking

- Information on braking _____ 108

Button in the driver's door

- Electrical power windows _____ 55

C

Car care _____ 132

- Jack _____ 138

Car computer

- see Multifunction display _____ 33

Car park ticket holder _____ 83

Carrier _____ 80

Cavity protection _____ 138

Central locking button _____ 51

Central locking system	49	on the front passenger seat	23	Coolant	150
lock	51	TOP TETHER	26	Checking	151
unlock	51	Use of child seats	24	Display messages	41
Changing		Use of ISOFIX child seats	25	Replenishing	151
brake fluid	152	Chrome parts		Warning light	41
bulbs	178	refer to Taking care of your vehicle	137	Coolant temperature gauge	
Changing the bulb for fog light (Scout)	181	Cigarette lighter	82	display	31
Fog lights and daytime running lights bulbs	180	Cleaning		Correct seated position	9
Front parking light bulb	180	Alcantara	141	Driver	9
Front turn signal bulb	180	Covers of electrically heated seats	141	Front passenger	10
High beam bulb - halogen projector headlights	179, 186	Fabrics	141	Instructions	11
light bulb in tail light	181	Headlight lenses	138	Rear seats	11
Low beam and high beam bulb - halogen headlights	179	Natural leather	140	Counter for distance driven	32
Wheels	166	Plastic parts	137	Cruise Control System	121
Changing a wheel		Synthetic leather	141	Cupholders	81
Follow-up work	167	Wheels	139		
Preliminary work	167	Cleaning vehicle	135	D	
Remove and attaching a wheel	167	Climatronic	95	DAY LIGHT	
Changing brake		automatic mode	96	see Daylight running lights	60
fluid	152	Control elements	95	Daylight running lights	60
Charging a vehicle battery	155	Controlling blower	96	Deactivating an airbag	20
Check		Defrosting windscreen	97	Decorative films	137
Fit ball head properly	128	Recirculated air mode	96	Defrosting rear window	64
Checking		Setting the temperature	96	Delayed locking of the boot lid	
Battery electrolyte level	154	Clock	32	see boot lid	55
Brake fluid	152	Clothes hook	83	Diesel	
Coolant	151	Cockpit		refer to Fuel	144
Engine oil	149	12-volt power outlet	82	Diesel fuel	
Oil level	149	Ashtray	81	Operation in winter	144
Windscreen washer fluid	147	Cigarette lighter	82	Diesel particulate filter	43
Checks		General view	29	display messages	43
Statutory checks	132	Lighting	63	Digital clock	32
Children and safety	22	Storage compartments	83	Dimmed headlights	59
Child safety		Compartments	83	Dipstick	149
Side airbag	24	Components of the puncture repair kits	170	Display	
Child safety lock	48	Computer		Service interval	36
Child seat		see Multifunction display	33	Distance driven	32
Classification	24	Convenience turn signal	61		
ISOFIX	25				

Door			
Child safety lock	48		
Closing	48		
Indicator light for an open door	40		
Opening	48		
Doors			
Emergency locking	49		
Driving			
Abroad	118		
Driving through water on streets	117		
Emissions	184		
Fuel consumption	184		
Maximum speed	186		
Driving economically			
Economical gear changing	114		
Driving through water	117		
E			
Economical and environmentally friendly driving	113		
Economical driving			
Ballast	115		
Driving at full throttle	115		
Idling	115		
Looking ahead	114		
Regular maintenance	116		
Saving energy	116		
Short distances	115		
Tyre pressure	115		
EDL	120		
Electrical power windows			
Button in the driver's door	55, 56		
Button in the rear door	56		
Central locking system	57		
Operational faults	57		
Electronic Differential Lock	120		
Electronic immobilizer	107		
emergency			
opening the loading door (Praktik)	89		
Emergency			
Changing a wheel	166		
Hazard warning light system	63		
jump-starting	172		
Jump-starting	172		
locking of the doors	49		
Selector lever-unlocking	112		
Towing the vehicle	173		
Towing the vehicle using the tow hitch	174		
tyre repair	169		
Unlocking the boot lid	55		
Emergency equipment			
Fire extinguisher	165		
First aid kit	165		
Jack	166		
Vehicle tool kit	166		
Warning triangle	165		
Emissions	184		
Engine			
Running in	113		
Starting and stopping the engine	106		
Switching off the engine	107		
Engine compartment	145		
Brake fluid	152		
Coolant	151		
Overview	147		
Vehicle battery	153		
Engine number	183		
Engine oil	148		
Capacity	148		
Checking	149		
Replenishing	150		
Specifications	148		
Warning light	40		
Engine revolutions counter	31		
Environment	113		
Environmental compatibility	116		
Environmentally friendly driving	113		
ESC			
Function	119		
Warning light	42		
F			
Films	137		
Fire extinguisher	165		
First aid kit	165		
Flashers	61		
Fog lights	61		
Folding down the seats	70		
Footmats	109		
see Footmats	109		
Front airbag	18		
Front seats	69		
Fuel	142		
Diesel	144		
Fuel gauge	31		
gauge	31		
refer to Fuel	142		
Refuelling	143		
Unleaded petrol	143		
Fuel consumption	113, 184		
Fuses			
Assignment	175		
Colour coding	175		
Replacing	175		
G			
Gear			
Recommended gear	32		
Gearbox			
Display messages	38		
Gear changing			
Gear stick	109		
General view			
Cockpit	29		
Genuine parts	133		

Glow plug system		Instrument cluster _____	30	Lock	
Warning light _____	43	Overview _____	30	Central locking system _____	51
GSM _____	97	see instrument cluster _____	30	Locking	
H		Interior monitor _____	54	Emergency locking _____	49
Handbrake _____	109	Internal lighting		Remote control _____	52
Hazard warning light system _____	63	Praktik _____	89	without central locking _____	49
Head airbag _____	19	Internal lights		Locking and unlocking from the inside _____	51
Headlight cleaning system		Praktik _____	89	Low tyre pressure warning	
Headlight cleaning system _____	67	ISOFIX _____	25	refer to the tyre pressure monitoring _____	125
Headlights _____	179	J		Luggage compartment	
Driving abroad _____	118	Jack _____	166	Class N1 vehicles _____	74
Headlight cleaning system _____	67	Maintenance _____	138	Lighting _____	64
Headrest		Jump-starting _____	172	Variable loading floor _____	76
Headrest _____	73	L		Luggage compartment lid _____	54
Head restraint _____	72	lashings		M	
Heating		Praktik _____	88	Main beam _____	61
Deicing the windows _____	92	Light		Maintenance _____	116
Exterior mirrors _____	68	Cockpit _____	63	Decorative films _____	137
Operating _____	91	Dimmed headlights _____	59	Manual air conditioning	
Operation _____	91	Headlight beam adjustment _____	60	Recirculated air mode _____	94
Rear window _____	64	Headlight flash _____	61	Manual gear changing	
Recirculated air mode _____	92	Sidelights _____	59	see gear changing _____	109
Seats _____	69	Lights		MAXI DOT	
Heating and air-conditioning _____	90	Cockpit _____	59	Main menu _____	37
Hill hold control _____	119	Cockpit _____	63, 64	see MAXI DOT display _____	37
Hitch _____	126	Daylight running _____	60	Settings _____	38
Accessories _____	129	Fog lights _____	61	MAXI DOT display _____	37
Drawback load _____	126	Foglights with the CORNER function _____	62	Maximum	
Horn _____	29	Halogen projector headlights with cornering light function _____	61	permissible weights _____	183
I		Hazard warning light system _____	63	Maximum speed _____	186
Ignition _____	107	Main beam lights _____	61	MDI _____	104
Ignition lock _____	107	Parking lights _____	63	Mechanical windows _____	58
Immobilizer _____	107	Rear fog light _____	62	open and close _____	58
Individual settings		Replacing bulbs _____	178	Media	
locking _____	50	Tourist lights _____	62	see radio / navigation system _____	4
unlocking _____	50	Turn signals _____	61		
Inertia reels _____	15	warning lights _____	39		

Mirror	
Exterior mirrors	68
Manually dimmed rear-view mirror	68
Vanity	65
Mobile phone	97
Connecting to the hands-free system	100
Modes of the automatic transmission	110
Modifications	132
Modifications and technical alterations	
Airbags	134
Service	133
Spoiler	134
Multifunction display	
Functions	33
Memory	33
Operation	34
Multimedia	103
N	
N1	74
Nameplate	183
Navigation system	4
Net partition	76
Notes for driving with tyre repaired	171
O	
Oil	
See Engine oil	149
Oil pressure	
Display messages	40
Onboard computer	
see Multifunction display	33
Operating weight	184
Operation in winter	
Diesel fuel	144
Vehicle battery	154
Original accessories	133
Outside temperature	34

Overview	
Engine compartment	147
warning lights	39
P	
Paintwork	
See Paintwork care	137
Paintwork care	137
Panoramic roof	65
Parking	
Parking aid	120
Part replacement	132
Passive safety	
Before setting off	8
Driving safety	8
Safety equipment	8
Passive Safety	8
Payload	184
Pedals	109
Footmats	109
Petrol	
refer to Fuel	143
Polishing the paintwork	
See Taking care of your vehicle	137
Power window force limiter	57
praktik	
adjusting the safety partition	88
Praktik	87
Adjustable safety partition behind the front seats	88
emergency release of the loading area door	89
Fastening the loading floor	88
Internal lighting	89
Internal lights	89
Puncture set	169
R	
Radiator fan	147
Radio	4

Radio reception	
See windows	138
Raising the vehicle	168
Rear-view mirror	
Exterior mirrors	68
Manually dimmed rear-view mirror	68
Rear fog light	62
rear seats	
in the longitudinal direction	70
Tilt the seat backrest	70
Rear seats	70
Rear Seats	
fold back into the starting position	72
Rear window heating	64
Recirculated air mode	
Manual air conditioning	94
Recommended gear	32
Refuelling	143
Fuel	143
Regulation	
Headlight beam	60
Remote control	52
Synchronisation process	53
Remote control key	
Replacing the battery	47
Repairs and technical alterations	132
Replacing	
Bulb for the licence plate light	181
Fuses	175
Fuses in the dash panel	176
Fuses in the engine compartment	177
Vehicle battery	155
Windscreen wiper blades	67
Replenishing	
Coolant	151
Engine oil	150
Windscreen washer fluid	147
Running-in	
The first 1500 km	113

Running in		Selector lever		Storage compartment	
Brake pads	113	see Using the selector lever	110	Storage compartment on the driver's side	84
Engine	113	Service	133	Storage compartment on the front passenger side	84
Tyres	113	Service display	36	Storage Compartment	
S		Setting		Lighting	64
SAFE		Heating	92	Storage compartments	83
see Safe securing	50	Manual air conditioning system	94	Flexible storage compartment	87
SAFELOCK		Manually dimmed rear-view mirror	68	Storage compartment in the front centre console	85
see Safe securing	50	Setting the clock		storage pockets on the front seat	84
Safe securing	50	Clock	32	Stowage	
Safety	8	Shifting gears		compartment beneath the front seat	85
Child safety	22	Driving and saving energy	114	compartment for glasses	85
Child safety seats	22	Side airbag	19	compartments in the doors	86
Correct seated position	9	Sidelights	59	compartments in the luggage	87
Head restraints	72	Snow chains	164	sun roof	65
ISOFIX	25	Spare wheel	159	sunshade	65
TOP TETHER	26	Speedometer	31	Sun visors	65
Safety belts		Speed symbol		Switching off the engine	107
rear middle seat	15	Refer to Wheels	161	Synthetic leather	141
Saving electrical energy	113	Spoiler	134	T	
Seals		Stalk		Taking care of the vehicle	
Taking care of your vehicle	137	Main beam	61	Natural leather	140
Seat		Turn signals	61	Seat belts	141
Adjusting	69	START-STOP	123	Taking care of your vehicle	
Seat belt		Manually deactivating/activating the system	124	Automatic car wash system	135
warning light	40	Operating conditions for the system	123	Cavity protection	138
Seat belts	12	operation	124	Chrome parts	137
Belt tensioners	15	system-related automatic start-up	124	Cleaning the wheels	139
Cleaning	141	Starting and stopping the engine	106	Decorative films	137
fastening and unfastening	14	Starting engine		Door lock cylinders	138
Height adjustment	15	Jump-starting	172	Headlight lenses	138
Inertia reels	15	Starting the engine	107	High-pressure cleaner	136
The physical principle of a frontal collision	13	Jump-starting	172	Plastic parts	137
Seats		Starting the engine	107	Polishing the paintwork	137
Head restraints	72	START STOP		Rubber seals	137
Heating	69	Information messages	124	Taking care of the interior	139
Removing seats	71	Jump-starting	173	Taking care of your vehicle exterior	136
Seats and stowing	69	Steering wheel	10		
		Storage	83		

Washing by hand _____	135	Trays		Useful equipment _____	80
Wash system _____	135	folding table in the middle back seat _____	86	12-volt power outlet _____	82
Wax treatment _____	137	Turning the light		Ashtray _____	81
Taking care of your vehicles		on and off _____	59	Car park ticket holder _____	83
Fabric covers _____	141	Turning the light on and off _____	59	Cigarette lighter _____	82
Technical data _____	183	Turn signals _____	61	Clothes hood _____	83
Telephone _____	97	Two-way radio systems _____	97	Cupholders _____	81
Temporary spare wheel _____	159	Tyre		Using the selector lever _____	110
the rear seats		Explanation of the labelling _____	160		
fold down seat backrest and fold seat fully forward _____	71	see wheels _____	160		
Tiptronic _____	111	Tyre load-bearing capacity			
Tire size		Refer to Wheels _____	161		
see wheels _____	161	Tyre pressure			
Tools _____	166	Indicator light _____	45		
TOP TETHER _____	26	Tyre pressure monitoring _____	125		
Tourist lights _____	62	Display _____	45		
Towing _____	173	Save tyre pressure values _____	125		
Towing a trailer _____	131	Tyre repair			
Towing device		Preparations _____	171		
Description _____	126	Pressure test _____	171		
Use and care _____	139	Sealing and inflating the tyre _____	171		
Towing eye		Tyres _____	156		
Front _____	174	Inflation pressure _____	157		
Rear _____	174	Sizes _____	157		
Towing protection _____	54	Tyre wear indicator _____	157		
Traction Control System (ASR) _____	120	Tyre size _____	160, 161		
Trailer _____	129	see wheels _____	160		
13-pin socket _____	130				
connection and disconnection _____	130				
Loading _____	130				
Safety eye _____	130				
Towing a trailer _____	131				
Trailer operation _____	126				
Transport					
Boot _____	73				
Roof rack system _____	80				
Transporting children safely _____	22				

		U			
Underbody protection _____	139				
Unleaded petrol _____	118				
unlock					
Central locking system _____	51				
Unlocking					
Remote control _____	52				
without central locking _____	49				
Unlocking and locking _____	47				
USB _____	104				

		V			
Variable loading floor _____	76				
Dividing the luggage compartment _____	77				
Removing and refitting _____	77				
Vehicle battery					
Automatic load deactivation _____	156				
Charging _____	155				
Checking the battery electrolyte level _____	154				
Cover _____	154				
Disconnecting and reconnecting _____	155				
Operation in winter _____	154				
Replacing _____	155				
Safety instructions _____	153				
Vehicle care					
Alcantara _____	141				
Fabrics _____	141				
Synthetic leather _____	141				
washing _____	135				
Vehicle data sticker _____	183				
Vehicle data sticker and nameplate					
Vehicle data sticker and nameplate _____	183				
Vehicle dimensions _____	185				
Vehicle height _____	185				
Vehicle Identification Number (VIN) _____	183				
Vehicle key _____	47				
Vehicle length _____	185				
Vehicle status					
see Auto Check Control _____	38				
Vehicle tool kit _____	166				
Vehicle width _____	185				

VIN		Tyre wear indicator	157
Vehicle Identification Number	183	Unidirectional tyres	158
Visors	65	Winter tyres	163
W		Window convenience operation	57
Warning lights	39	Windows	138
Warning symbols		Deicing	138
see warning lights	39	See Electrical power windows	55
Warning triangle	165	Window wipers	
Washing		Replacing the rear window wiper blade	67
Automatic car wash system	135	Windscreen	
by hand	135	Deicing	138
Chrome parts	137	Windscreen washer fluid	
High-pressure cleaner	136	Checking	147
Washing vehicles	135	Replenishing	147
Water		Warning light	45
Driving through	117	Winter	147
Wax treatment		Windscreen washer system	147
See Taking care of your vehicle	137	Windscreen wash system	
Weather conditions	132	Windscreen washer	66
Wheel bolts		Windscreen wiper	
Anti-theft wheel bolts	169	Operate	66
Caps	160	Windscreen wipers	
Loosening and tightening	168	Cleaning the windscreen wiper blades	67
Wheel rims	156	Replacing the windscreen wiper blades	67
Wheels		Windscreen washer fluid	147
Changing	166	Winter	
Full trim	159	Deicing windows	138
General information	156	Winter operation	163
Load index	161	Snow chains	164
Replacing wheels	157	Winter tyres	163
Service life of tyres	157	Winter tyres	
Snow chains	164	See Wheels	163
Spare wheel	159		
Speed symbol	161		
Storing wheels	157		
Temporary spare wheel	159		
Tyre pressure	157		
Tyre size	160, 161		
Tyre sizes	157		

Reprinting, reproduction, translation, or any other use, either in whole or in part, is not permitted without the written consent of ŠKODA AUTO a.s.

ŠKODA AUTO a.s. expressly reserves all rights relating to copyright laws.

Subject to change.

Issued by: ŠKODA AUTO a.s.

© ŠKODA AUTO a.s. 2014

ŠKODA Service App - ŠKODA service in your pocket

The application ŠKODA service is provided for Smartphones with Android or iPhone systems. This task is mainly to help you as a customer of ŠKODA AUTO in difficult situations when on the road.

My Dealer – select your preferred dealer and read about their current offer or ŠKODA news.

Assistance – Contact a breakdown recovery service, find the nearest dealer when on the road and use the service Parking Helper.

My car – the complete operating instructions and a summary list of all the warning lights for a quick overview, a guide for media systems and Quick Tips.



Ready for download in the AppStore for iOS and Google Play for Android.

ŠKODA Manual App - get to know your vehicle

The application ŠKODA Manual is designed for tablet users with the systems Android and iOS, who have an interest in getting to know the ŠKODA vehicle brand or already have one. The application contains the complete version of the electronic manual for all current models of the ŠKODA brand. Furthermore, it contains a list of all warning lights, a guide for media systems as well as a picture diagram of the Quick Tips.

Some of the main functions of the application include:

- › Easy content navigation
- › Easy content reading
- › Full text search through the entire manual
- › Tab for quick access to favourite chapter



www.skoda-auto.com

You also can do something for the environment!

The fuel consumption of your ŠKODA and the related pollutant emissions are determined crucially on how you drive.

The noise and the wear of the vehicle depend on the way how you deal with your vehicle.

This Owner's Manual shows you how to use your ŠKODA vehicle with utmost care for the environment while driving economically at the same time.

Also please pay attention to those parts in the Owner's Manual that are marked  below.

Work with us - for the sake of the environment.

Návod k obsluze
Roomster anglicky 11.2014
S80.5610.16.20
5J7012720AH



5J7012720AH